

Directory

		Page
1. Product overview	Basic-Line-Module AXN	3
2. Product description	Basic-Line-Module AXN	4-5
Guide system	Roller guide	6
Drive system	Gear belt	7
3. Basic-Line-Modul	AXN 45-Z	8-9
	AXN 65-Z	10-11
	AXN 80-Z	12-13
	AXN 100-Z	14-15
4. Drive adaptor	AXN-Z	shaft extension / motor-adaptor
		gearboxes
		drive connecting shaft
5. Limit- / Position switch	Switch mounting on AXN	20
	specifications	21
6. Fixing- and connecting parts	Fixing border / sliding block	22-23
	AXN direct- / cross- / entrance connection	24-26
7. Complete systems	Standard design	27
8. T-slot cover	AXN 45 / 65 / 80 / 100	28
9. Model description	AXN 45 / 65 / 80 / 100	29
10. Application form		30

Product overview

Basic Line Module AXN



AXN 45



AXN 65



AXN 80



AXN 100

Product overview

Basic Line Module AXN

	AXN 45-Z	AXN 65-Z	AXN 80-Z	AXN 100-Z
Profil cross section w x h (mm)	45x48	65x68,5	80x84	100x100
Drive	gear belt			
Feed rate per rotation (mm)	100	150	180	230
Max. dynamic working Load (N)	325	650	1450	2500
Repeat accuracy (mm)	±0,05	±0,05	±0,05	±0,05
Max. speed (m/s)	6	10	10	10
Guide system	LR24	LR35	LR42	LR52
Max. total length overall (m) *	6	6	6	6
P_R (N)	570	995	1735	2150
P_L (N)	570	995	1735	2150
P_T (N)	1030	1940	2950	4500
M_A (Nm)	16	35	83	125
M_B (Nm)	30	70	146	330
M_C (Nm)	6	17	36	75

* in one part – longer version on request

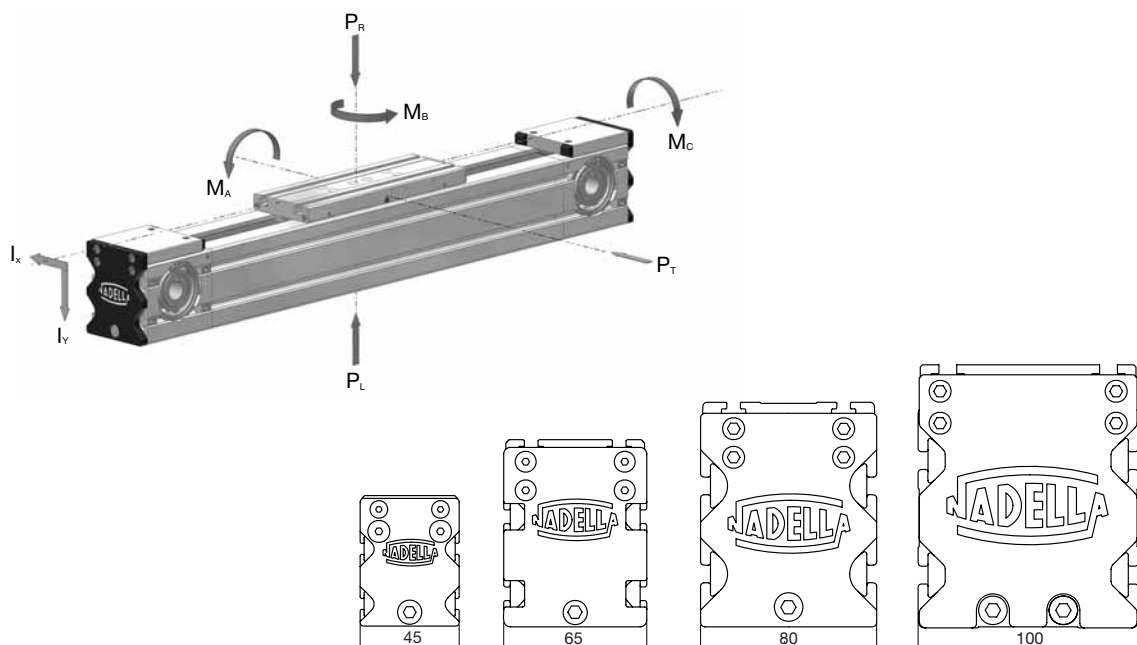

Product description

Basic Line Module AXN

High performance and low costs are the outstanding features of this model range. If individual module or multi system: Depending on customers' requirements various combinations are possible.

Universal motor connection

Nearly all usual flange motors can be connected by metal bellow or elastomer claw couplings with the corresponding motor adapters.

Gear belt tensioning device

For space and cost reasons the basic line modules are equipped with gear belt tensioning devices that are located below the table plate. By positive belt retainers the gear belt gets tension and laterally secured.

Lifetime lubrication

The bearings of the rollers and the belt pinions are lubricated for life. At any movement the steel shafts of the roller guides are coated by a thin lubricant film coming from an integrated system. In case of a high travel mileage and/or acceleration values it is possible to refill this system through lubricating nipples at the table plate.

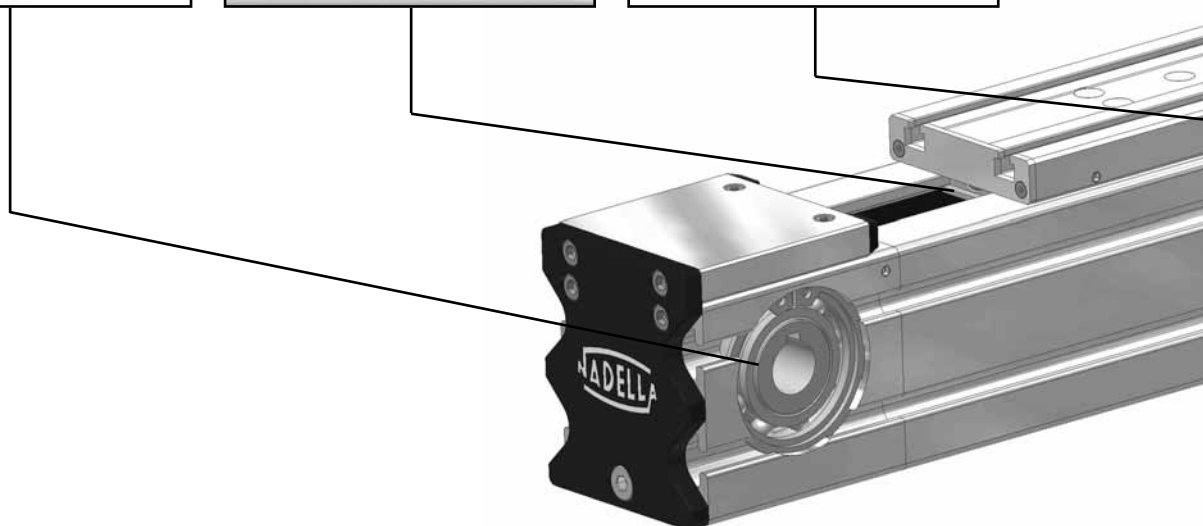
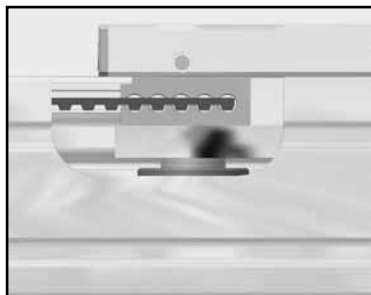
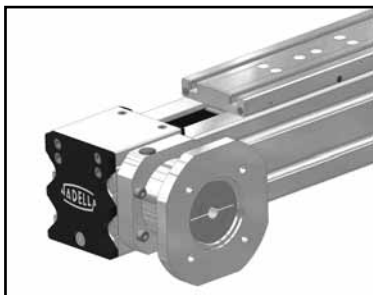

Product description

Basic Line Module AXN

Roller guide

The characteristic features of the roller guide are cost-saving, nearly maintenance-free concomitant with high-performance. Resistance to soiling and smooth running is achieved by rollers of large dimensions.

Integrated wiper brushes

The actuator profil of the basic line modules is covered on the upper side by the circular gear belt. Wiper brushes integrated in the head covers prevent effectively larger dirt particles from penetrating into the profile.

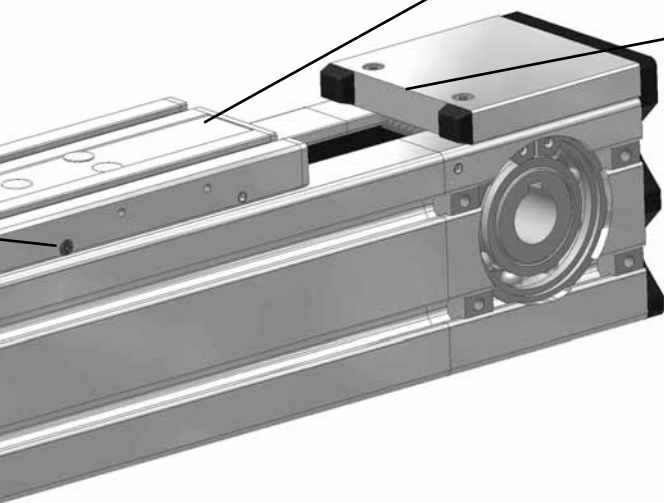
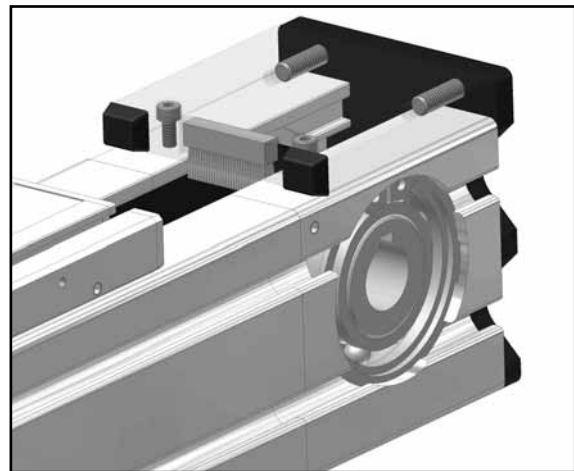
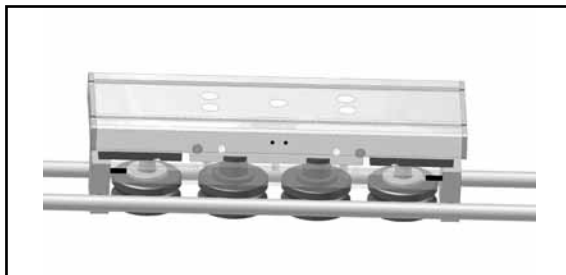

Assembly and fixation of the actuator

Two longitudinal slots in the table plates (thread at AXN 45) make it easily possible to install the moving parts. By end-to-end T-slots at the bottom and on either side of the actuator a universal installation of the module is possible. In this application adequate swivelling sliding blocks with spring element can be supplied (for AXN 80 and AXN 100 also DIN slot nuts).

Product description

Drive system

Guide roller system

All sizes in the AXN line are generally provided with a roller guide system. This system consists of four roller guides, which roll along hardened steel ground shafts built into the aluminium profile.

An integrated lubrication system makes sure, that the roller guide gets enough grease for a long lifetime.



As a result of the eccentric bearing arrangement of the two roller guides, the guide system can be precisely adjusted and thus given the correct preload or zero backlash at the factory. This technology ensures that the roller guide system also offers outstanding operating performance.

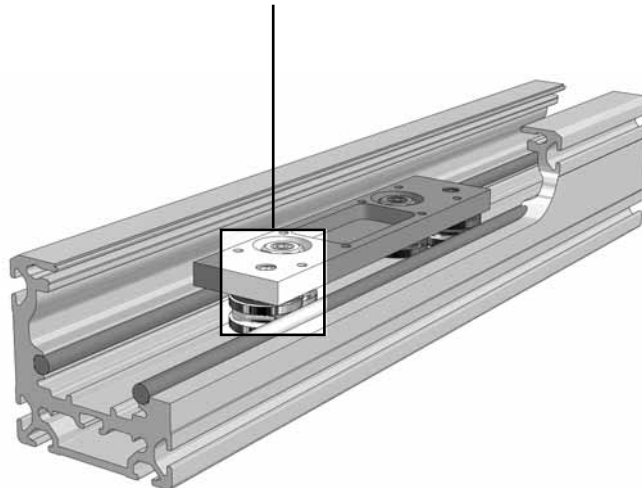

Load capacities

The dynamic load capacity of this linear motion system is based on an average speed of 1.5 m/sec. (toothed belt drive), with a nominal service life of 10 000 hours in continuous operation. For deviating parameters, and for complex load situations, please refer to our calculation service.

Product description

Drive system

Toothed belt drive

Attached operating heads with integrated belt pulleys are an attribute of the AXN-Actuators.

The basic-line modules AXN have been developed by maximum power rating and highest cost-benefit ratio. Operating head and deflection head are identical and will be hold in store pre-assembled. So, if stroke is known the actuators can be built in shortest time.

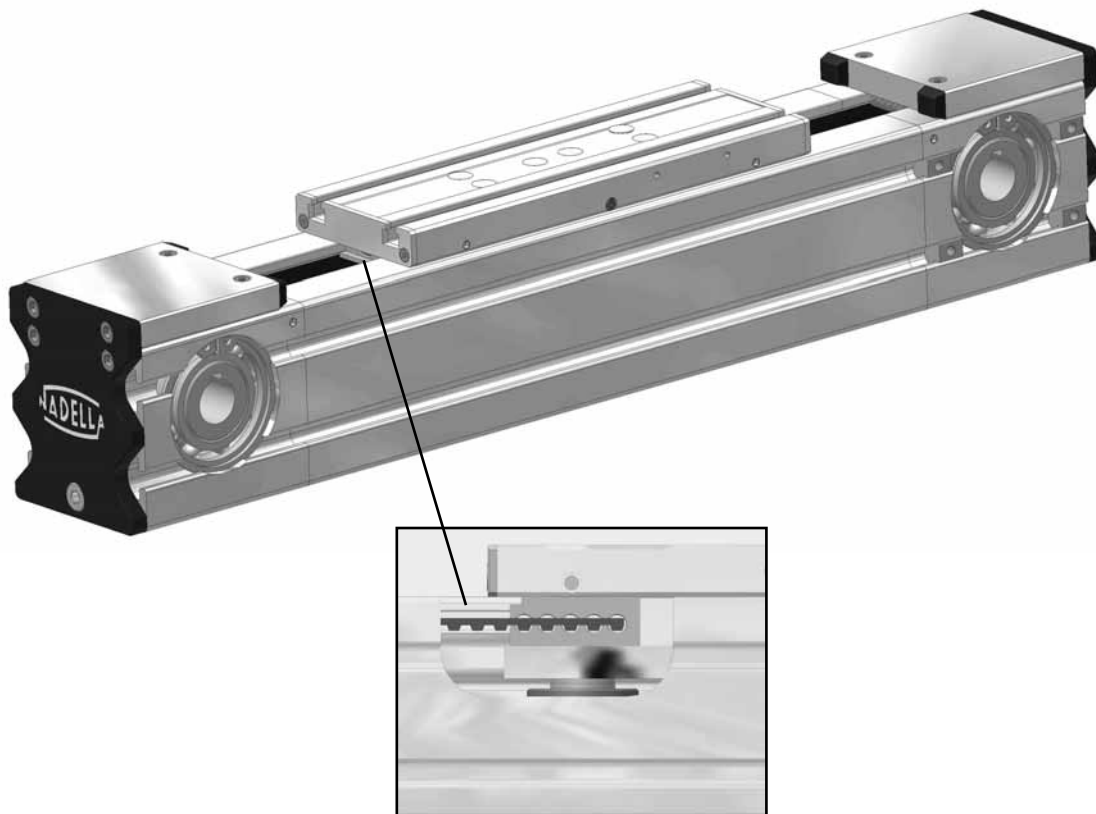

Toothed belt clamping

The ingenious design of the belt clamp enables the full width of the belt to be clamped with uniform strength so that the full load capacity of the toothed belt is guaranteed.

Basic Line Module

AXN 45-Z

Actuator with gear belt and roller guide

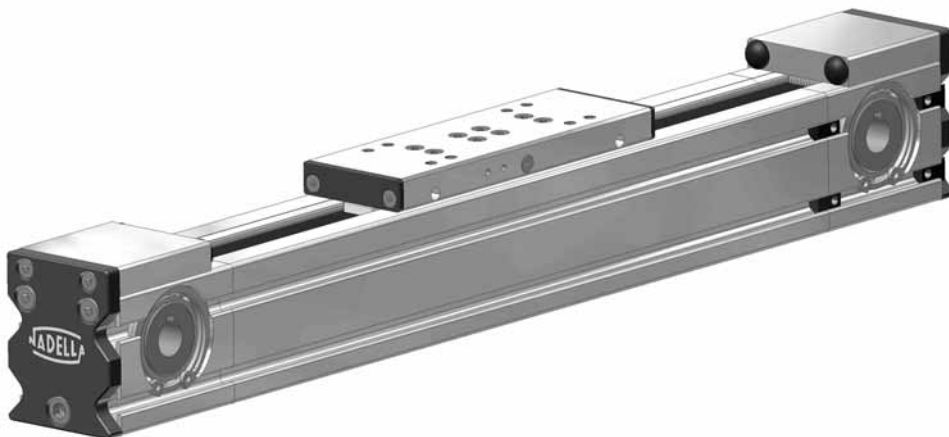
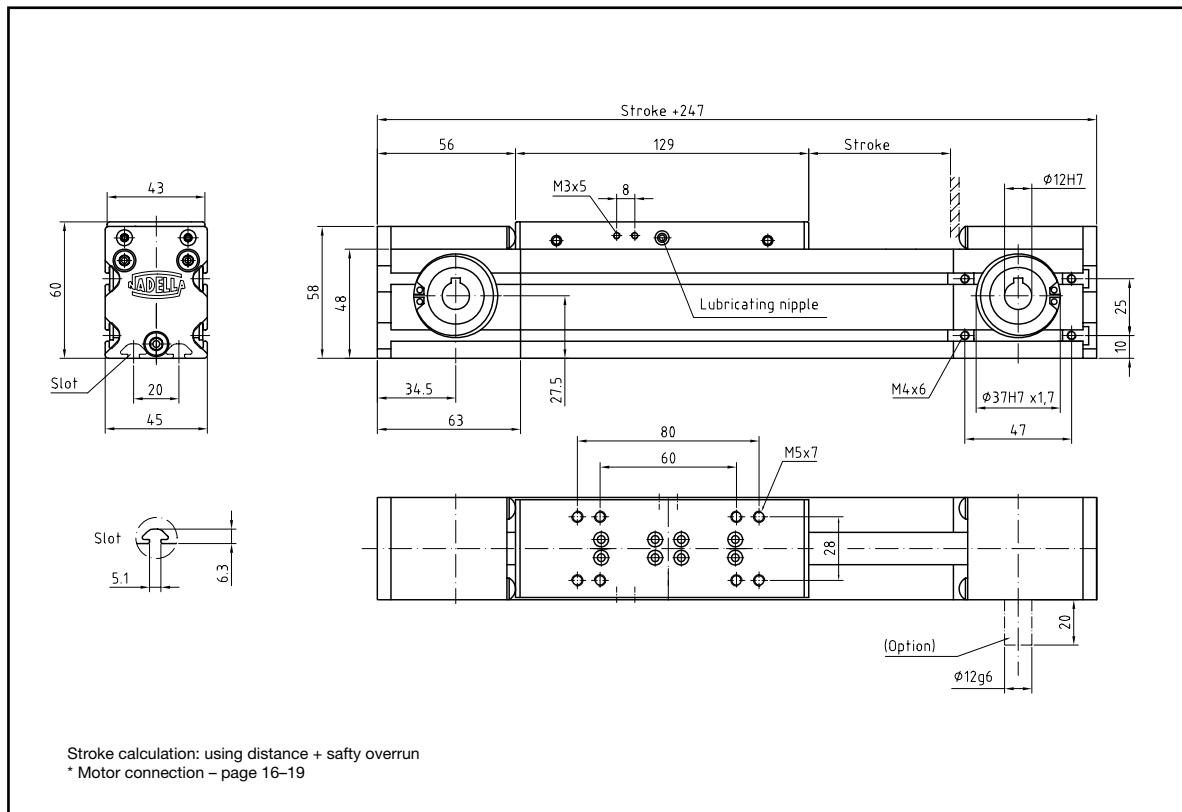

Basic Line Module

AXN 45-Z

Loads and load moments*

Roller guide 24.06		
Loads (N)	dyn.	stat.
P_R	570	1040
P_L	570	1040
P_T	1030	1810
Load moments (Nm)		
M_A	16	27
M_B	30	54
M_C	8	15

*Maximum load see definition on page 6

Technical data

Max. speed	max. 6 m/s
Repeating accuracy	$\pm 0,05$ mm/m
Actuation	gear belt 16 AT5
Max. dynamic working load (N)	325 N
Feed rate per rotation (mm)	100 mm
Idle-running torque	0,2-0,3 Nm
Moment of inertia	0,383 Kgcm ²
Max. length overall (m) ¹⁾	6 m
Geometrical moment of inertia I_x	21,7 cm ⁴
Geometrical moment of inertia I_y	22,5 cm ⁴

¹⁾ Greater length upon request

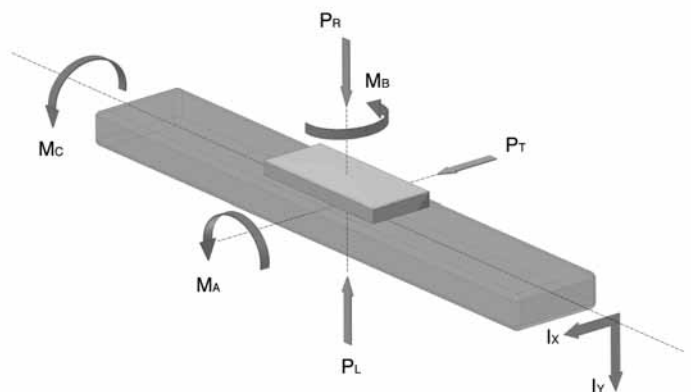

Mass

	Roller guide
Basic mass	1,8 Kg
Mass per 100 mm stroke	0,3 Kg
Slide mass	0,5 Kg

Basic Line Module

AXN 65-Z

Actuator with gear belt and roller guide

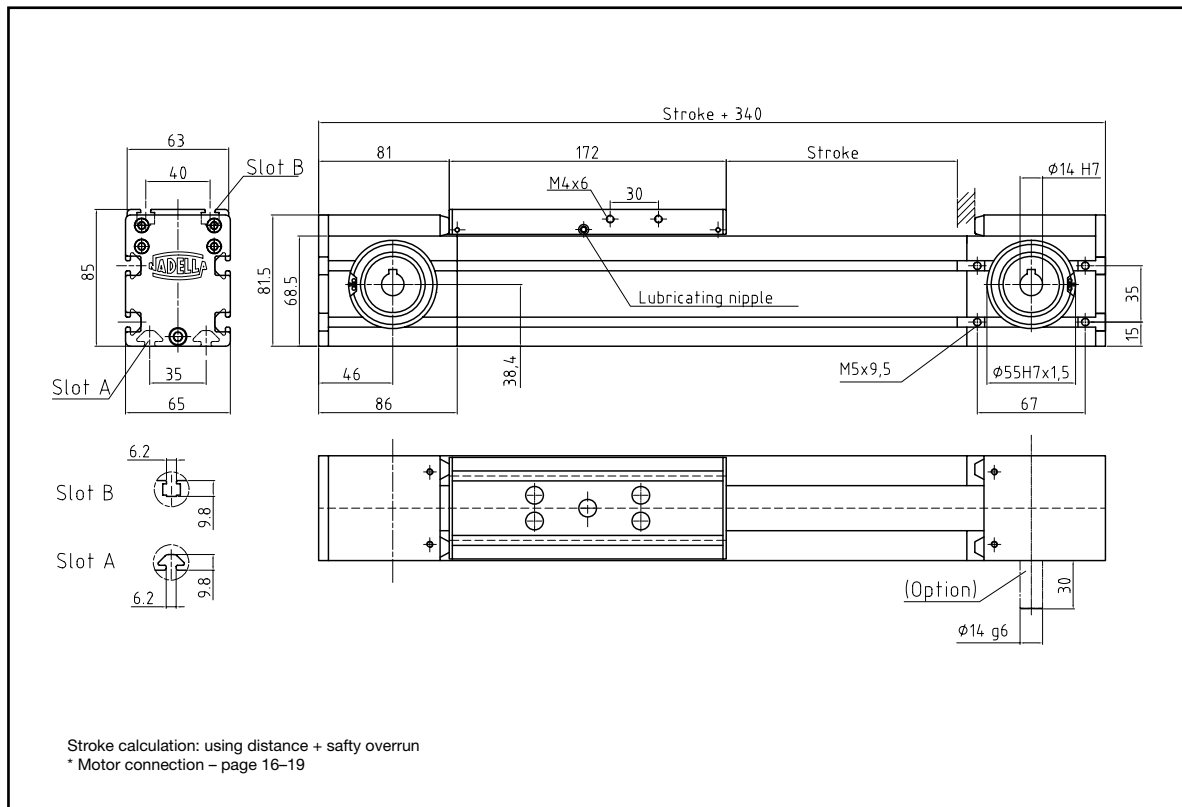

Basic Line Module

AXN 65-Z

Loads and load moments*

Roller guide 35.10		
Loads (N)	dyn.	stat.
P_R	995	2400
P_L	995	2400
P_T	1940	3200
Load moments (Nm)		
M_A	30	75
M_B	70	120
M_C	20	40

*Maximum load see definition on page 6

Technical data

Max. speed	max. 10 m/s
Repeating accuracy	$\pm 0,05$ mm/m
Actuation	gear belt 32 AT5
Max. dynamic working load (N)	650 N
Feed rate per rotation (mm)	150 mm
Idle-running torque	0,8-1,0 Nm
Moment of inertia	2,994 Kgcm ²
Max. length overall (m) ¹⁾	6 m
Geometrical moment of inertia I_x	80,2 cm ⁴
Geometrical moment of inertia I_y	89,2 cm ⁴

¹⁾ Greater length upon request

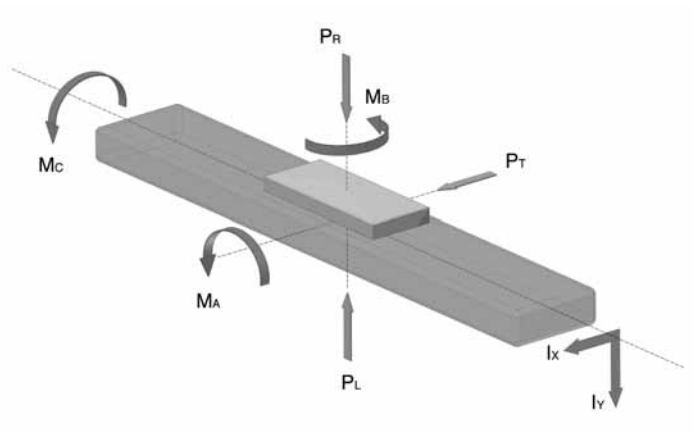

Mass

	Roller guide
Basic mass	4,8 Kg
Mass per 100 mm stroke	0,6 Kg
Slide mass	1,5 Kg

Basic Line Module

AXN 80-Z

Actuator with gear belt and roller guide

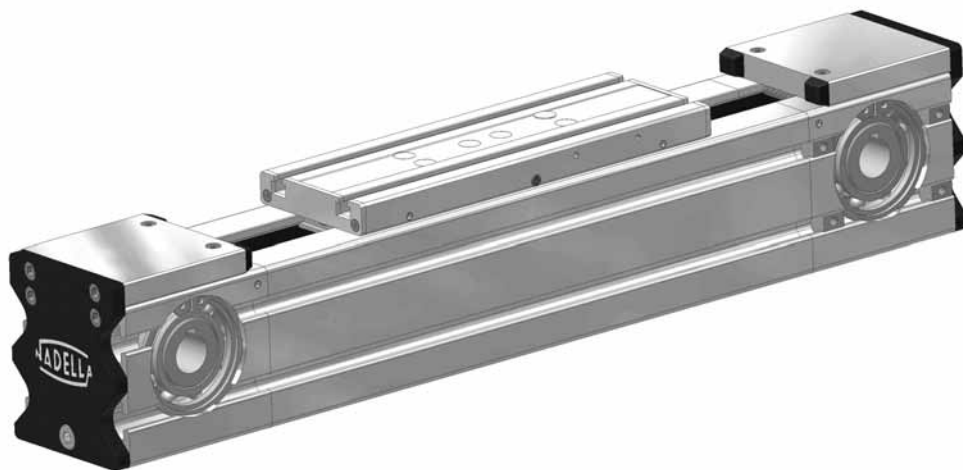
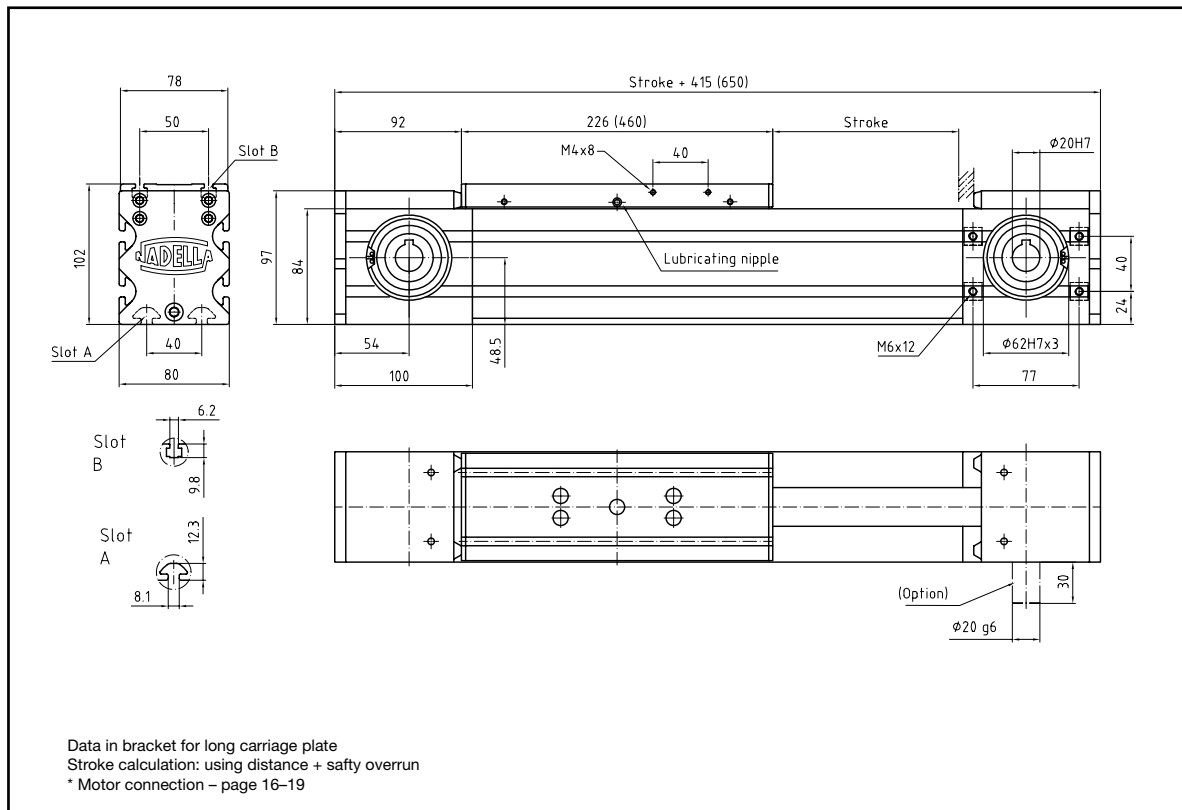

Basic Line Module

AXN 80-Z

Loads and load moments*

Roller guide 42.10				
Loads (N)	dyn.		stat.	
P_R	1735	(2950)	3000	(5100)
P_L	1735	(2950)	3000	(5100)
P_T	2950	(5000)	5250	(8900)
Load moments (Nm)				
M_A	83	(245)	143	(425)
M_B	146	(365)	260	(635)
M_C	36	(60)	62	(100)

*Maximum load see definition on page 6

Technical data

Max. speed	max. 10 m/s
Repeating accuracy	$\pm 0,05$ mm/m
Actuation	gear belt 32 AT10
Max. dynamic working load (N)	1450 N
Feed rate per rotation (mm)	180 mm
Idle-running torque	1,0-1,2 Nm
Moment of inertia	5,237 Kgcm ²
Max. length overall (m) ¹⁾	6 m
Geometrical moment of inertia I_x	198,5 cm ⁴
Geometrical moment of inertia I_y	207,4 cm ⁴

¹⁾ Greater length upon request

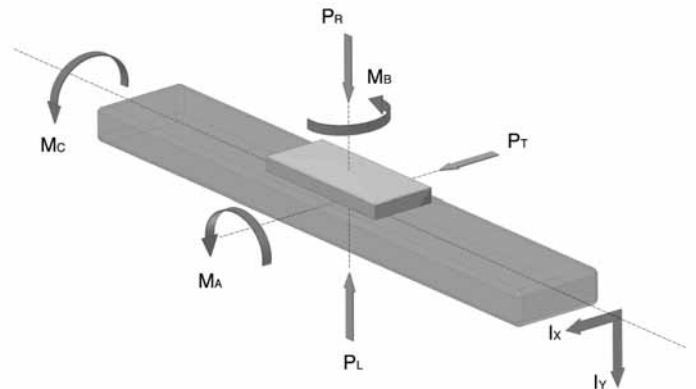

Mass

	Roller guide
Basic mass	8,5 Kg
Mass per 100 mm stroke	0,9 Kg
Slide mass	2,3 (4,6) Kg

Basic Line Module

AXN 100-Z

Actuator with gear belt and roller guide

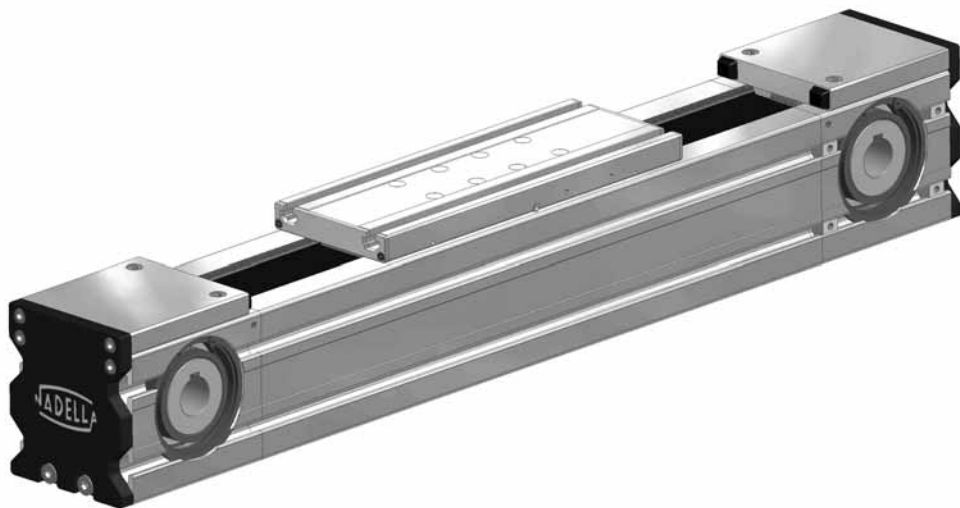
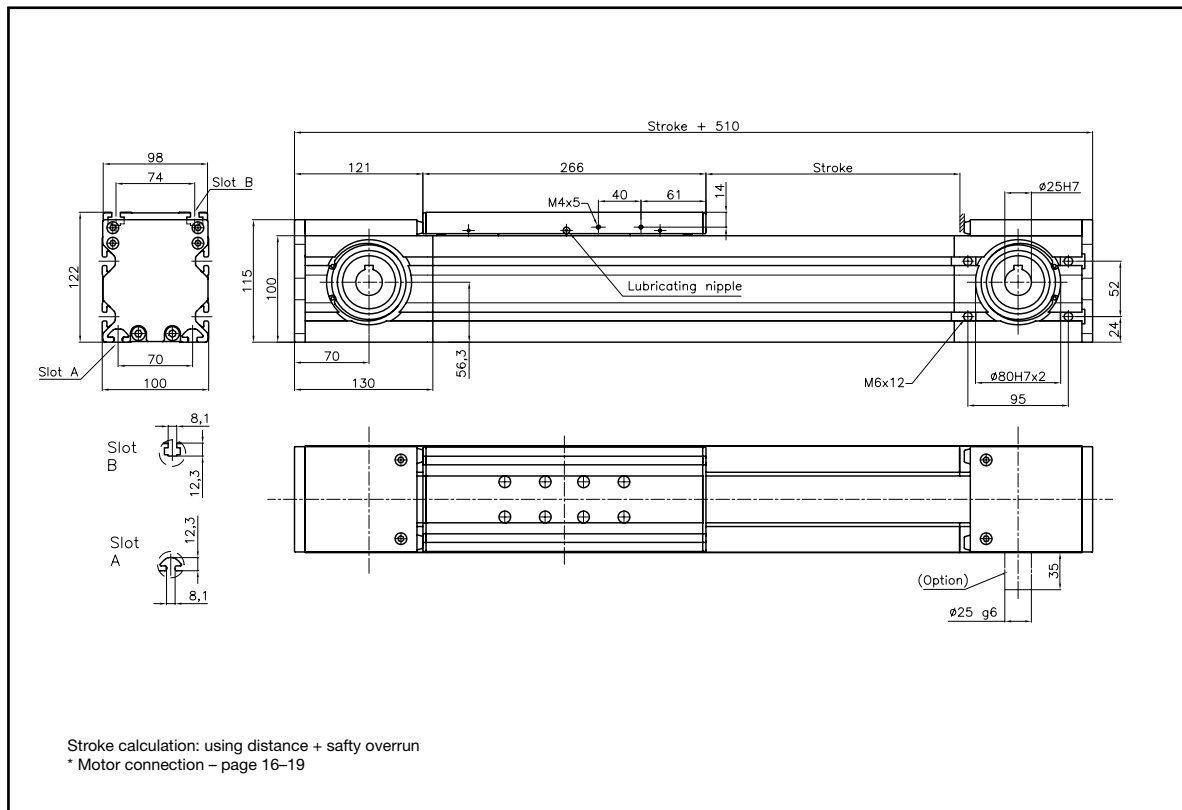

Basic Line Module

AXN 100-Z

Loads and load moments*

Roller guide 52.16		
Loads (N)	dyn.	stat.
P_R	2150	3200
P_L	2150	3200
P_T	4500	7000
Load moments (Nm)		
M_A	125	170
M_B	330	400
M_C	75	110

*Maximum load see definition on page 6

Technical data

Max. speed	max. 10 m/s
Repeating accuracy	$\pm 0,05$ mm/m
Actuation	gear belt 50 AT10
Max. dynamic working load (N)	2500 N
Feed rate per rotation (mm)	230 mm
Idle-running torque	ca. 3 Nm
Moment of inertia	14 Kgcm ²
Max. length overall (m) ¹⁾	6 m
Geometrical moment of inertia I_x	343 cm ⁴
Geometrical moment of inertia I_y	465 cm ⁴

¹⁾ Greater length upon request

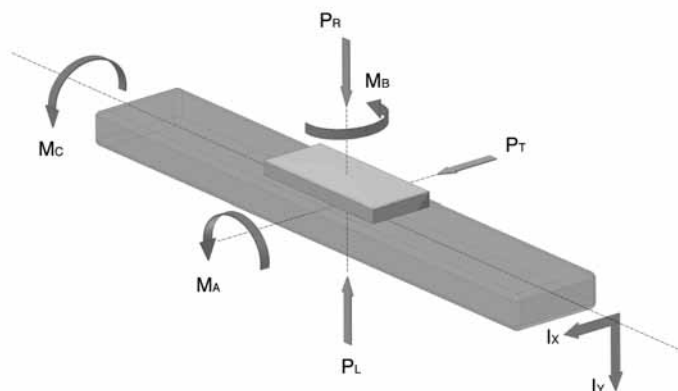

Mass

	Roller guide
Basic mass	16 Kg
Mass per 100 mm stroke	1,4 Kg
Slide mass	4,4 Kg

Drive Adaption

Basic Line Module AXN

Dimensions “free shaft extension”

In addition to the standard actuators with hollow boring it is possible to provide drive shafts for each AXN size. You can select this optional on one or both sides. Necessary slot nuts for the attachment of a motor adaptor are included in delivery.

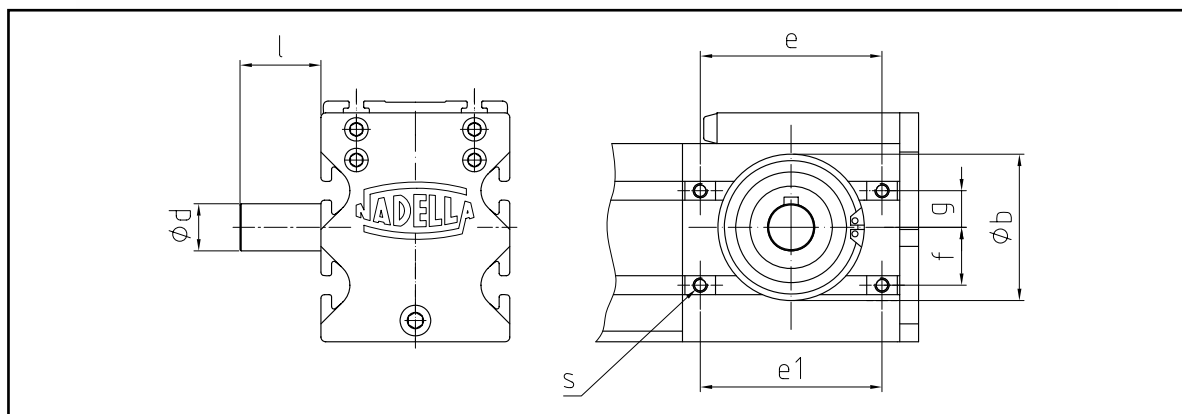
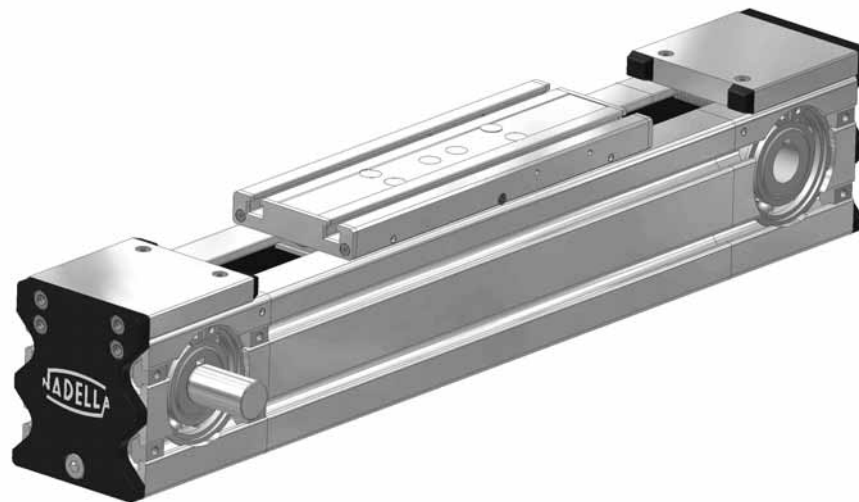

Drive shaft single-sided (left or right) or two-sided

Size	b H7	d g6	e1 min.	e	f	g	l	s
AXN 45	37 x 1,7	12	37	47	17,5	7,5	20	M4 x 6
AXN 65	55 x 1,5	14	56	67	23,4	11,6	30	M5 x 9,5
AXN 80	62 x 3	20	68	77	24,5	15,5	30	M6 x 12
AXN 100	80 x 2	25	95		32,3	19,7	35	M6 x 12

Drive Adaption

Basic Line Module AXN

Coupling box / motor flange

Standardized motor flange combinations (MFC) allow to attach nearly all prevalent gears or geared motors. The coupling (metal bellow or elastomer coupling) and flanges will be adapted according to the specifications given for the drive that shall be mounted. Closely tolerated connections allow also high drive torque with fast reversing operations.

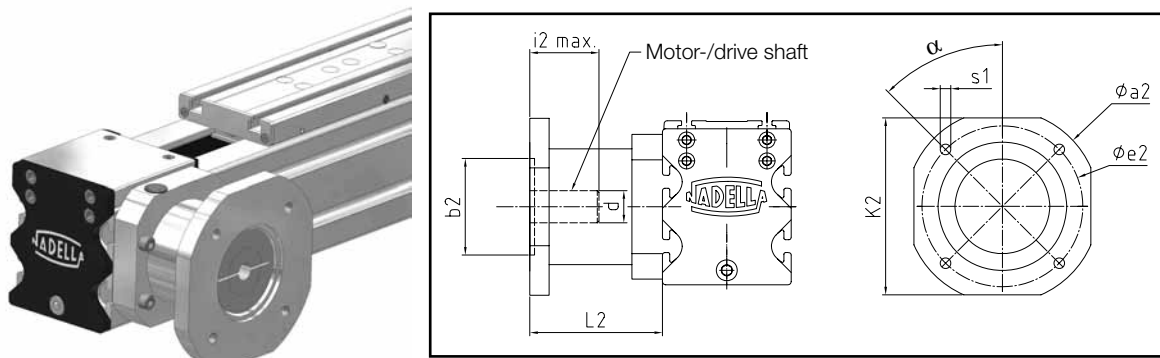

Module	Design	e2		α	s1	b2		d	i2max.	k2	a2	L2
		min.	max.			min.	max.					
AXN 45	B5	46	63	0°	4x M5 x9	36	55	6 - 16	31	75	80	55
	B5	46	70	45°	4x M5 x9	36	60	6 - 16	31	75	80	55
	B14	50	63	0°	4x Ø 5,5	36	55	6 - 16	31	75	80	55
	B14	50	70	45°	4x Ø 5,5	36	60	6 - 16	31	75	80	55
AXN 65	B5	60	80	0°	4x M5 x12	52	72	8 - 28	40	90	100	72,5
	B5	60	90	45°	4x M5 x12	52	82	8 - 28	40	90	100	72,5
	B14	67	80	0°	4x Ø 5,5	52	72	8 - 28	40	90	100	72,5
	B14	67	90	45°	4x Ø 5,5	52	82	8 - 28	40	90	100	72,5
AXN 80	B5	70	105	0°	4x M6 x 12	60	95	12 - 32	43	120	130	77
	B5	70	115	45°	4x M6 x 12	60	105	12 - 32	43	120	130	77
	B14	80	105	0°	4x Ø 6,6	60	95	12 - 32	43	120	130	77
	B14	80	115	45°	4x Ø 6,6	60	105	12 - 32	43	120	130	77
AXN 100	B5	60	140	0°	4x M6 x 15	50	130	12 - 35	60	-	150	101,5
	B5	60	140	45°	4x M6 x 15	50	130	12 - 35	60	120	150	101,5
	B14	62	138	0°	4x Ø 6,6	50	126	12 - 35	60	-	150	101,5
	B14	62	138	45°	4x Ø 6,6	50	126	12 - 35	60	110	150	101,5

Drive Adaption

Basic Line Module AXN

Planetary gear

Cost-saving planetary gears for high requirements can be included in delivery upon customers demand. Single-stage or two-stage gears with little circumferential backlash are mounted through specially matched coupling connections.



Possible actuator – gear combinations

gear	PLE 40	PLE 60	PLE 80	PLE 120
Actuator				
AXN 45	x	x		
AXN 65		x	x	
AXN 80			x	
AXN 100			x	x

Gear data

	Gear	PLE 40	PLE 60	PLE 80	PLE 120
gear ratio	1-stage	3; 4; 5; 8			
	2-stage	9; 12; 15; 16; 20; 25; 32; 40; 64			
max. output torque T (Nm) ¹⁾	1-stage	6-15	18-40	50-115	120-195
	2-stage	7,5-20	18-44	50-120	120-260
max. middle rotary speed at 50% T (min-1)		5000	4500	4000	3500
circumferential backlash (arcmin) ²⁾	1-stage	< 24	< 16	< 9	< 8
	2-stage	< 28	< 20	< 14	< 12
moment of inertia (Kgcm ²) ¹⁾	1-stage	0,031-0,017	0,135-0,065	0,77-0,39	2,63-1,32
	2-stage	0,03-0,016	0,131-0,064	0,74-0,39	2,62-1,3
weight (Kg)	1-stage	0,35	0,9	2,1	6,0
	2-stage	0,45	1,1	2,6	8,0
centering seat for motor fitting (mm) ³⁾		30	40	80	95
hole circle for motor fitting (mm) ³⁾		46	63	100	115
Motor shaft d max. (mm) ³⁾		6	9	14	19
Motor shaft length L (mm) ³⁾		25	23	30	40
overall length (mm)	1-stage	68	72	94	122
	2-stage	81	84	111	149

1) depending on transmission ratio! Attention to admissible working load of the linear actuator.

2) Restricted circumferential backlash on request.

3) Other dimensions on request.

Drive Adaption

Basic Line Module AXN

Drive connecting shaft

For higher loads, the actuators can be parallelly connected. Power is transmitted by a connecting shaft. Thus the actuator modules can be used as a portal or multi-actuator system.

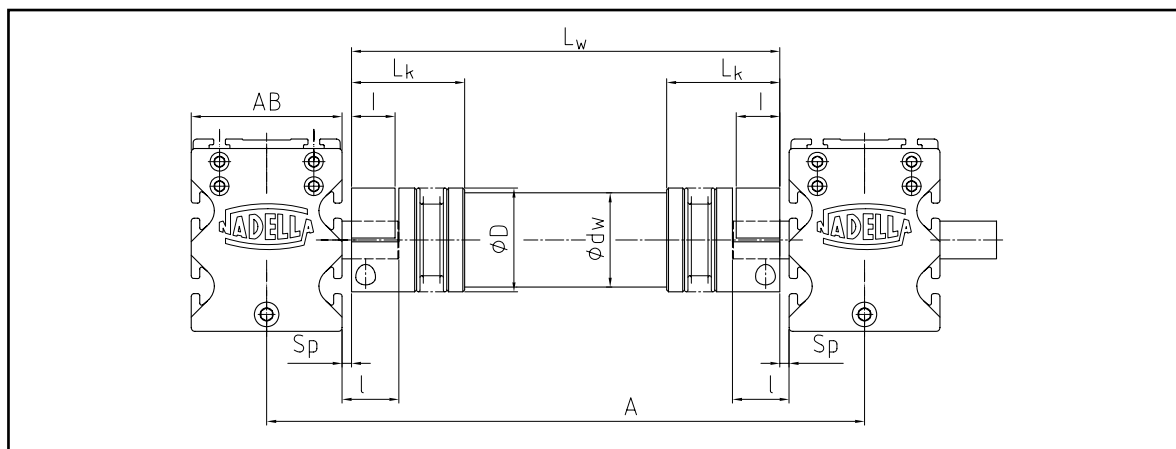

Module	T_{KN} (Nm)	A min. ¹⁾	I	Sp. ¹⁾	Sp. min. ²⁾	I	LW ¹⁾	D	d _w	L _k	A _B
AXN 45-VBW	10	162	20	8,5	1,0	10,0	A-62	40	35	39,5	45
AXN 65-VBW	10	202	30	18,5	1,5	10,0	A-102	40	35	39,5	65
	30	221		13,0	2,0	15,0	A-91	55	50	52,0	65
AXN 80-VBW	30	236	30	13,0	2,0	15,0	A-106	55	50	52,0	80
	60	258		9,0	2,5	19,0	A-98	66	60	64,0	80
AXN 100-VBW	60	288	35	14,0	2,5	19,0	A-128	66	60	64,0	100
	75	283		4,0	2,5	31,0	A-108	57	50	63,0	100

1) possibility to demount without demounting of the actuators

2) demounting of the connecting shaft only after demounted actuator

$$L_w = A - (2 * A_B / 2) - (2 * Sp)$$

Technical modifications are reserved.



Limit switch / Reference switch

Basic Line Module AXN

Switches mounting

For more safeness it is recommended to install limit switches for linear modules driven by electric motors. Positions can be controlled or signals can be derivated by mechanical or inductive switches.

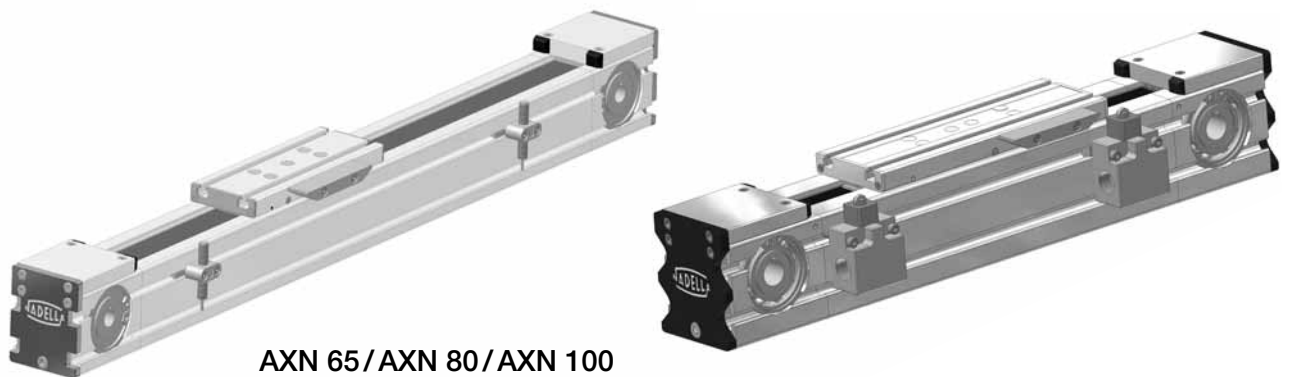

Upon request, our basic line modules can also be equipped with a combination of rugged mechanical or inductive switches. They are fixed in the T-slots of the profile so that a flexible positioning is possible. The switching contact is made by control cams.

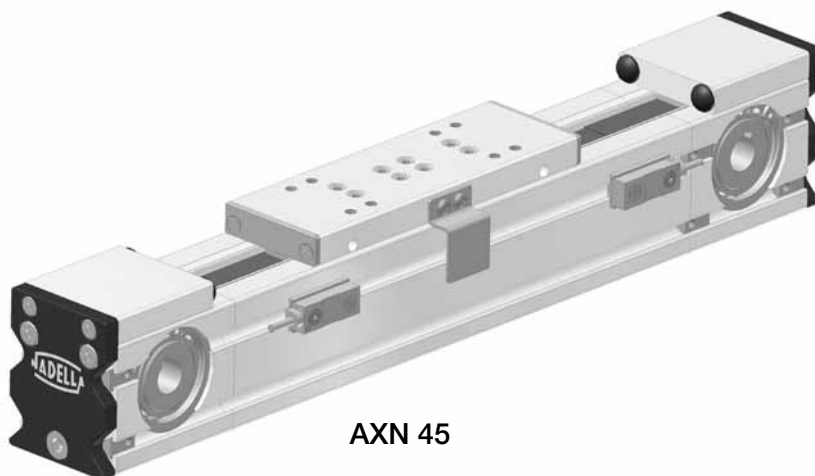

Limit switch / Reference switch

Basic Line Module AXN

Technical data of Switches

Mechanical switches

	life cycle	Housing material	access connection	protection class
Switch M1 AXN 65 / 80 / 100	30 x 10 6 switching cycles	plastic material	M20 x 1,5 Conductor cross-section 0,5...1,5 mm ²	IP 67

Inductive switches

	connection voltage	max. Load current	switching precision	cable length	protection class
Switch I4 PNP-NCC or -NOC AXN 65 / 80 / 100	10..30 V DC	200 mA	$\leq 10\%$ of switching distance	3 m	IP 67
Switch I5 PNP-NCC or -NOC AXN 45	10..30 V DC	100 mA	$\leq 10\%$ of switching distance	3 m	IP 67

Fitting dimensions

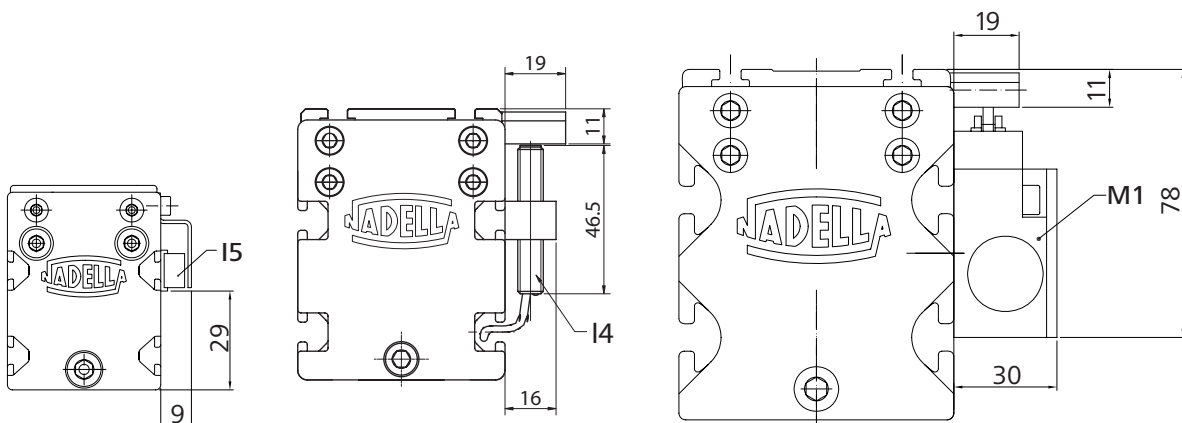

Inductive switch I5
for AXN 45

Inductive switch I4
for AXN 65/80/100

Mechanical switch I1
for AXN 65/80/100

Fastening and joining elements

Basic Line Module AXN

Fastening shoulder

For fixing the different linear actuators an optimally coordinated range of fastening elements is available. Slot nuts, fastening shoulders and adapter offer manifold possibilities to bolt the modules with each other or on mounting surfaces. Further fastening or fitting elements can be produced according to the customers` request.

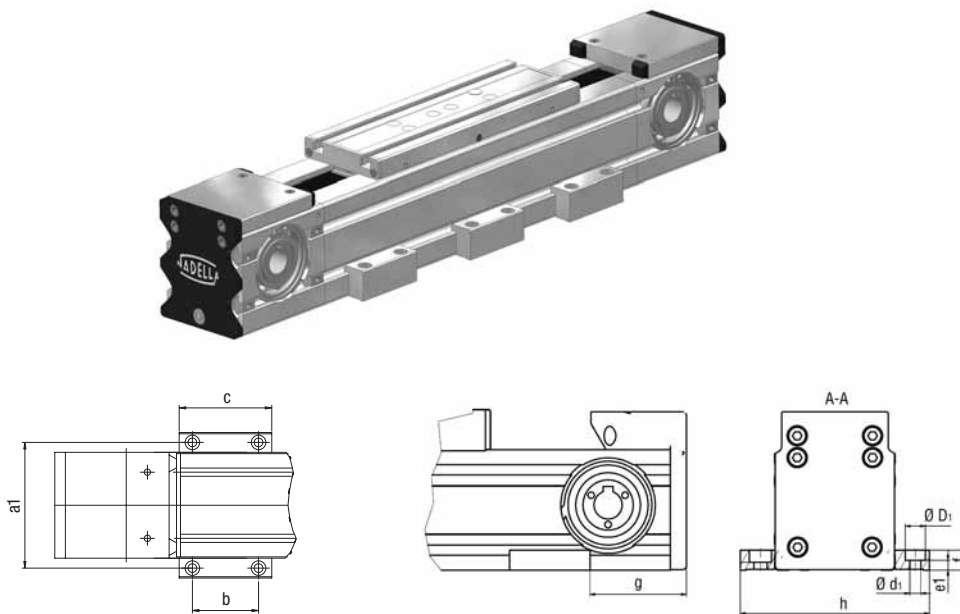

AXN Fastening shoulder

Actuator	Type	a1	b	c	d1	D1	e1	f	g ¹⁾	h
AXN 45	AXN 45 Bfl. Bk4 ¹⁾	60	-	20	5,5	10	5,5	11	68	74
AXN 45	AXN 45 Bfl. B44	60	28	41	5,5	10	5,5	11	68	74
AXN 65	AXN 65 Bfl. B64	80	28	41	5,5	10	11,5	17	95	97
AXN 65	AXN 65 Bfl. Bk6 ¹⁾	80	-	20	5,5	10	11,5	17	95	97
AXN 65	AXN 65 Bfl. B66	80	40	60	5,5	10	11,5	17	95	97
AXN 80	AXN 80 Bfl. B86	95	40	60	6,6	11	18,5	25	105	111
AXN 80	AXN 80 Bfl. Bk8 ¹⁾	95	-	25	6,6	11	18,5	25	105	111
AXN 80	AXN 80 Bfl. B88	95	50	70	6,6	11	18,5	25	105	111
AXN 100	AXN 100 Bfl. B1010	114	74	95	6,6	11	18	25	110	130

¹⁾ short version with only one fixing hole

The number of fastening shoulders depends on the load and the length of the linear actuator

Fastening and joining elements

Basic Line Module AXN

Slot nuts

Type E

- standard slot nut
- steel zinc coated
- can be swivelled in any position
- fixed by spring ball



Slot nut acc. to DIN

- slot nut for heavy loads
- steel black finished
- installed ex works
- without fixation

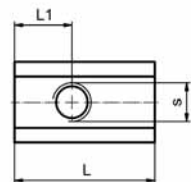

AXN slot nuts

Linear actuator	Type	design	S	L	L1 ¹⁾	TA (Nm)	max. tensile force
AXN 45	slot nut 5 ST M3	E	M3	12	3	1,5	500
	slot nut 5 ST M4	E	M4	12	4	3,0	500
	slot nut 5 ST M5	E	M5	12	4	4,5	500
AXN 65 AXN 80 only carriage slot	slot nut 6 ST M4	E	M4	17	5	4,0	1750
	slot nut 6 ST M5	E	M5	17	5	8,0 ²⁾	1750
	slot nut 6 ST M6	E	M6	17	5,5	14 ²⁾	1750
AXN 80 only profile slot AXN 100	slot nut 8 ST M5	E	M5	22	9	8,0 ²⁾	2500
	slot nut 8 ST M6	E	M6	22	9	14 ²⁾	3500
	slot nut 8 ST M8	E	M8	22	9	25	5000
AXN 80 AXN 100	slot nut DIN 508 M6	DIN	M6	13	6,5		

1) max. values, different dimensions possible

2) strength category 10.9 is necessary by using the max. clamping torque

Fastening and joining elements

Basic Line Module AXN

Direct connection

Modular construction system

Complete connection sets including all necessary fastening elements allow to mount single actuators on customers` construction. Also it is easily possible to combine multi-actuator systems.

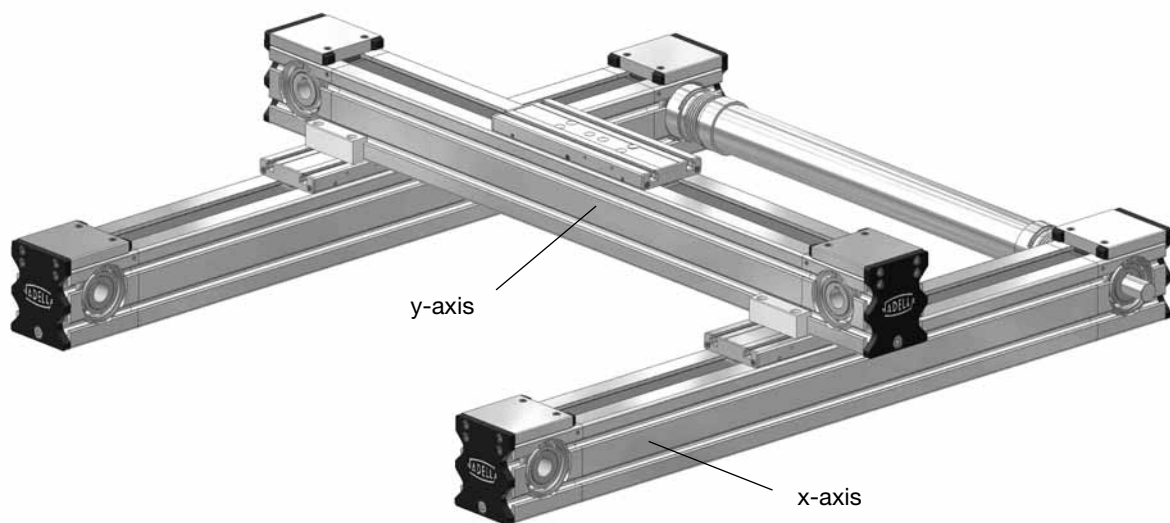

X-Axis	Y-Axis			
	AXN 45	AXN 65	AXN 80	AXN 100
AXN 45	connection set D 44	connection set D 46		
AXN 65		connection set D 66	connection set D 68	
AXN 80			connection set D 88	connection set D 810
AXN 100				connection set D 1010

For individual dimensions of the fastening shoulder, please see page 22

If direct connections should be used, it needs minimum one complete connection set. On the picture above you can see one y-axis AXN 80, mounted at two x-axis as a portal-system. For this application two connection sets D68 were used.

Fastening and joining elements

Basic Line Module AXN

Cross connection

Cross connections by standardized adapter plates. Especially for square actuator connections or radial arm systems in which the attached actuator shall move (complete profile), the cross connection plates allow a cost-saving assembly.

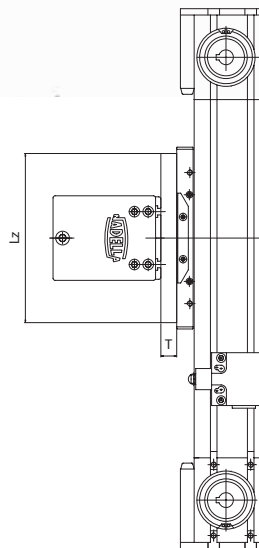
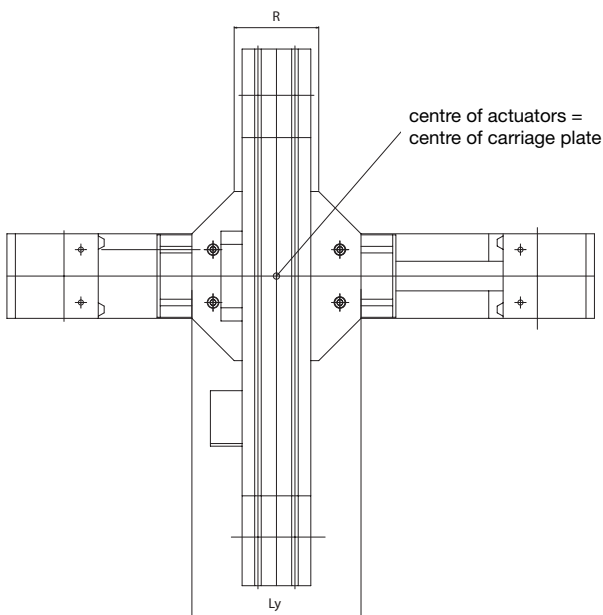
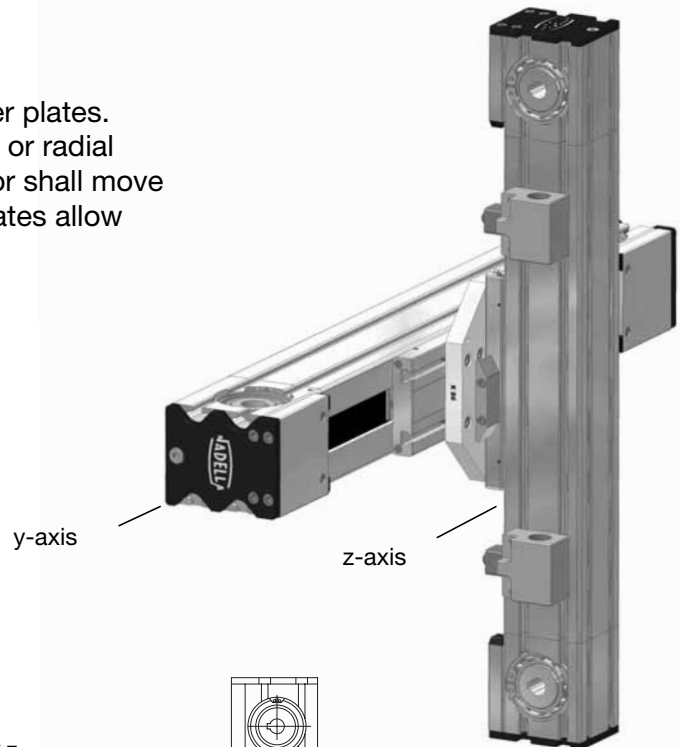

Y-Axis	Z-Axis	L_y	L_z	R	T	Type
AXN 45	AXN 45	100	100	65	10	AXN cross connection K44
AXN 65	AXN 45	100	100	65	10	AXN cross connection K64
AXN 65	AXN 65	140	140	65	12	AXN cross connection K66
AXN 80	AXN 65	160	160	80	15	AXN cross connection K86
AXN 80	AXN 80	160	220	80	15	AXN cross connection K88
AXN 100	AXN 80	220	220	110	15	AXN cross connection K108
AXN 100	AXN 100	230	230	100	15	AXN cross connection K1010

Fastening and joining elements

Basic Line Module AXN

Portal connection

Connection plate for “table-profile-connections”

With our portal connection plates workable and cost saving AXN portals can be realized without large excess lengths at the transverse actuator. The chart below shows the sizes available in a set (one plate including all necessary fastening elements).

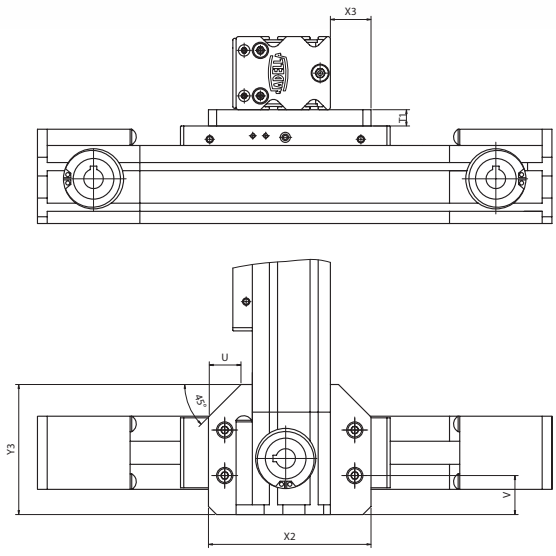
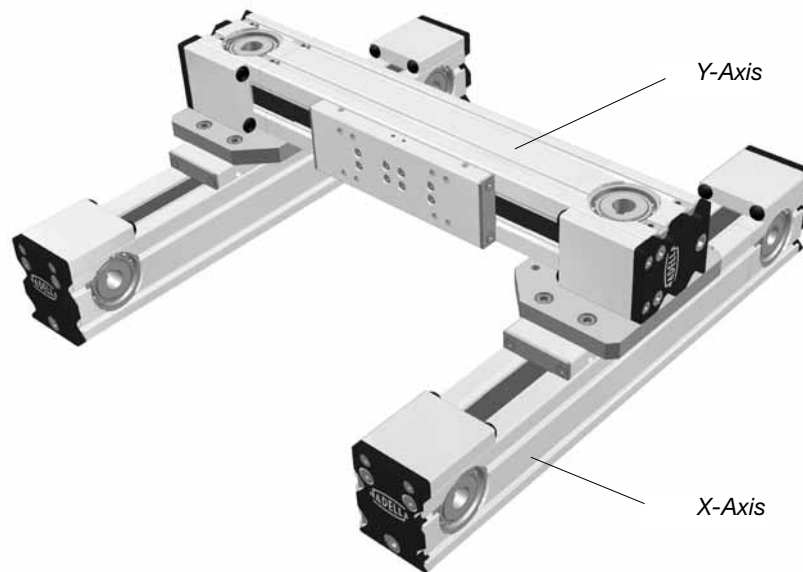

X-Axis	Y-Axis	T1	U	V	X2	X3	Y3	Type
AXN 45	AXN 45	10	27	24	100	27,5	80	AXN 45 Portal T44
AXN 45	AXN 65	12	20	32	100	17,5	104	AXN 45 Portal T46
AXN 65	AXN 65	12	25	26	130	32,5	104	AXN 65 Portal T66
AXN 65	AXN 80	15	24	34	120	16	117	AXN 65 Portal T68
AXN 80	AXN 80	15	24	29	140	26	117	AXN 80 Portal T88
AXN 80	AXN 100	15	45	40	180	40	155	AXN 80 Portal T810
AXN 100	AXN 100	15	45	33,5	190	45	160	AXN 80 Portal T1010

Multi-body-systems

Assembly example AXN

Basic Line Module AXN

More than only a single acting actuator! AXN Basic-Line-Modules are well thought out, high capacity and cost saving basic version.

Single actuators are also available as multi actuator systems. Upon customers request we can deliver fastening shoulders, limit switches, coupling housing, planetary gear, drive connecting shaft as a completion to our AXN-Modules.

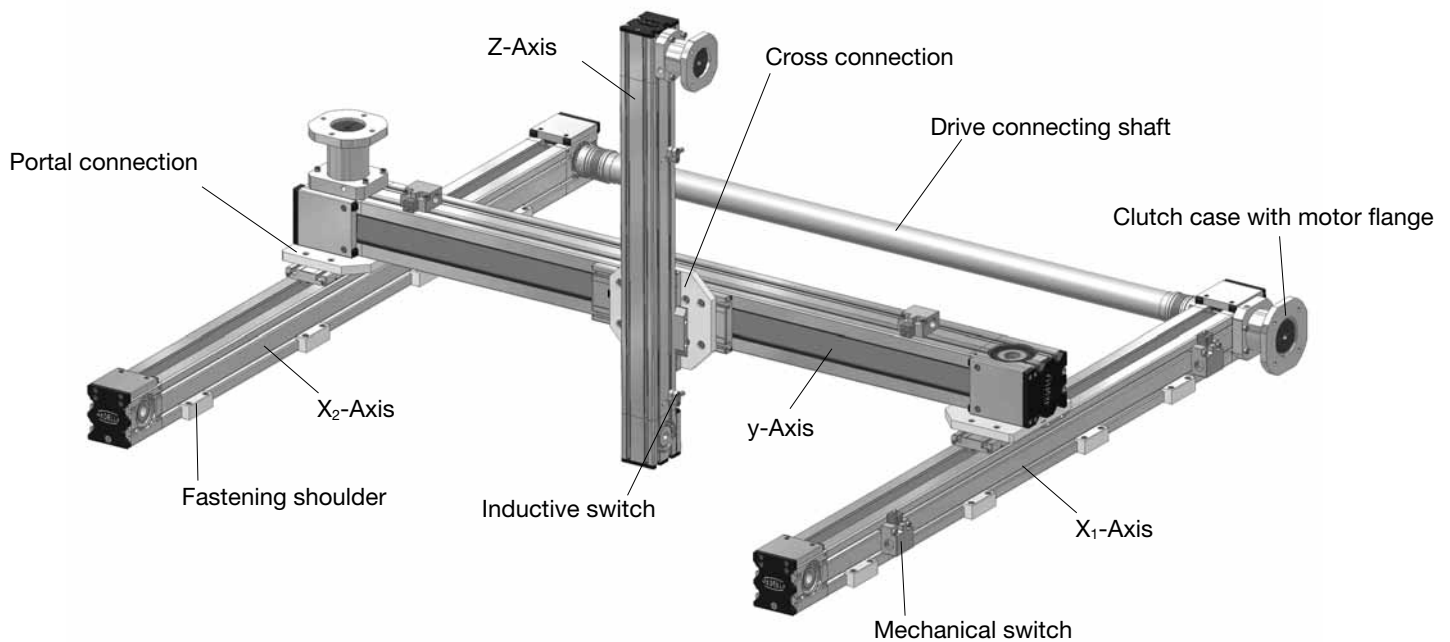

Slot covers

Basic Line Module AXN

For applications in the sight area or in case of increased soiling the profile slots can be closed with suitable synthetic or aluminium covers. Thus dirtiness fouling in the T-slots is not possible. The actuator gets a closed outer surface.

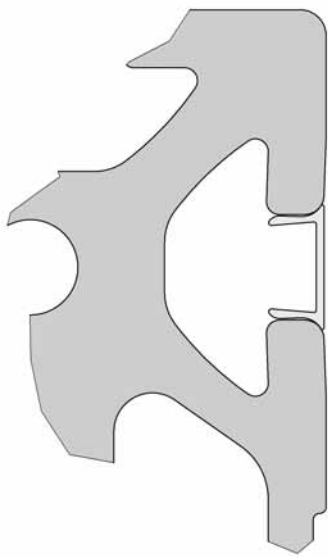

Cover profile AL
Colour: silver-coloured

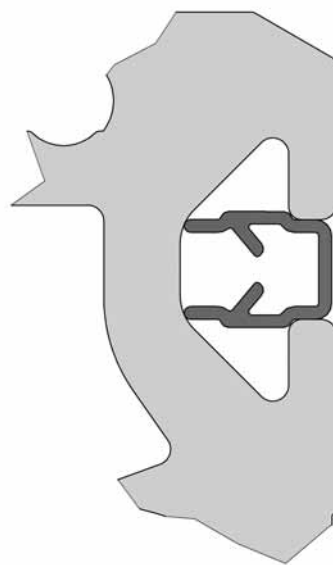

Cover profile PP
Colour: black

Linear actuator	Size	Article designation	Material
AXN 45	slot 5	cover profile 5 PP	synthetic black
AXN 65	slot 6	cover profile 6 AL over profile 6 PP	aluminium ecru synthetic black
AXN 80 / AXN 100	slot 8	cover profile 8 AL cover profile 8 PP	aluminium ecru synthetic black

Type designation for AXN Module

Ordering example

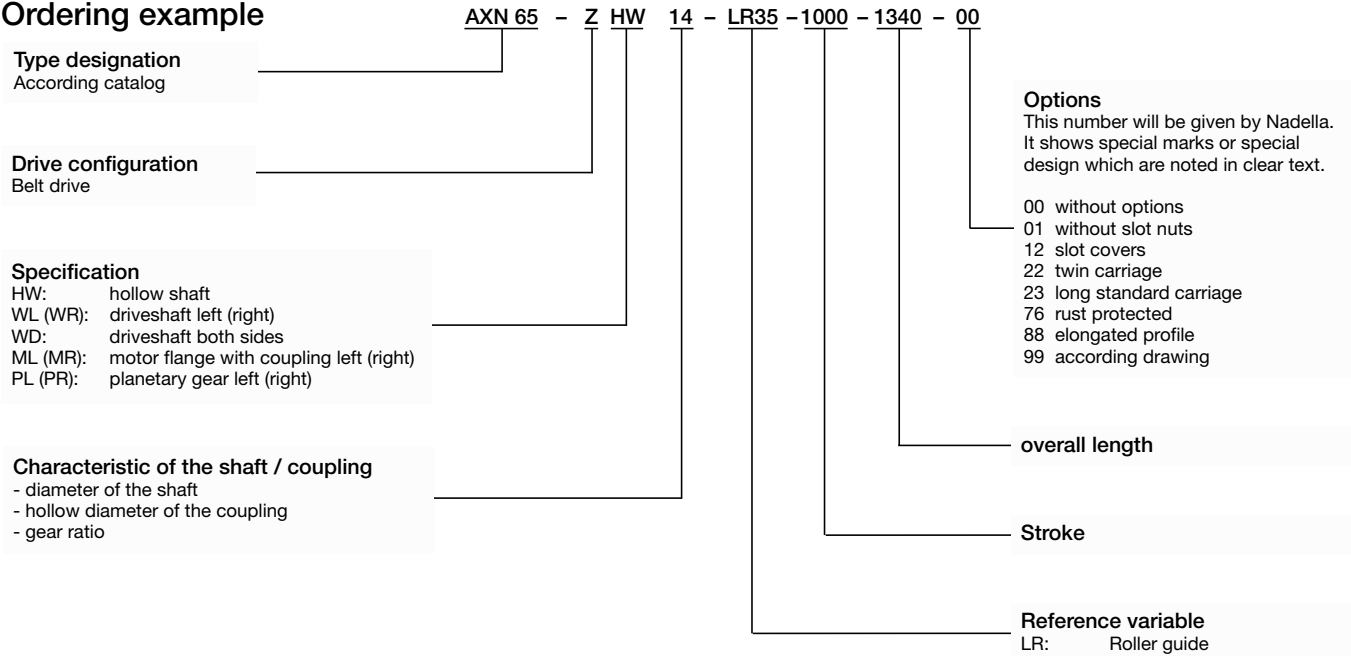

Fax 0049 7032 9540-25

Application Form

Company _____ Date _____

Address _____ Street _____

Contact person _____ Department _____

Phone _____ Email _____

Project designation _____

New processing

Technical advancement

Replacement needs

Singular demand

Serial need

Number of units _____

Desired date (units / calendar week) _____

Application parameter

Actuator type: _____ Axis: X _____ Y _____ Z _____

Singular axis / parallel axis (distance) _____

Installation position (horizontal/vertical) _____

Stroke _____

Load capacity (Kg) _____

Speed v (m/sec) _____

Acceleration a (m/s²) _____

Cycle time (sec) _____

Required life time (cycle/hours/Km) _____

If possible please send us a sketch or drawing of your application.

Assortment of options:

Mechanical switches

Motor flange (Please send us data-sheets of motor which you want to fit on)

Inductive switches

Gear box

Gear ratio

Motor-type: _____ Servo motor Step motor Three-phase motor with gearbox

Attachment for linear axis

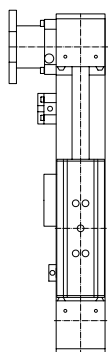

Left-side attachments

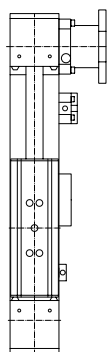

Right-side attachments

Central coordinates

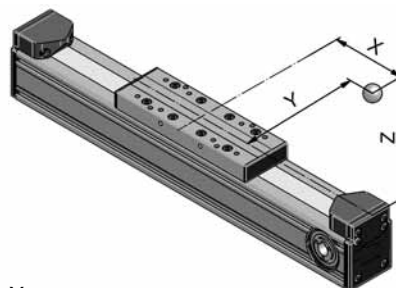

X _____

Y _____

Z _____

Notes

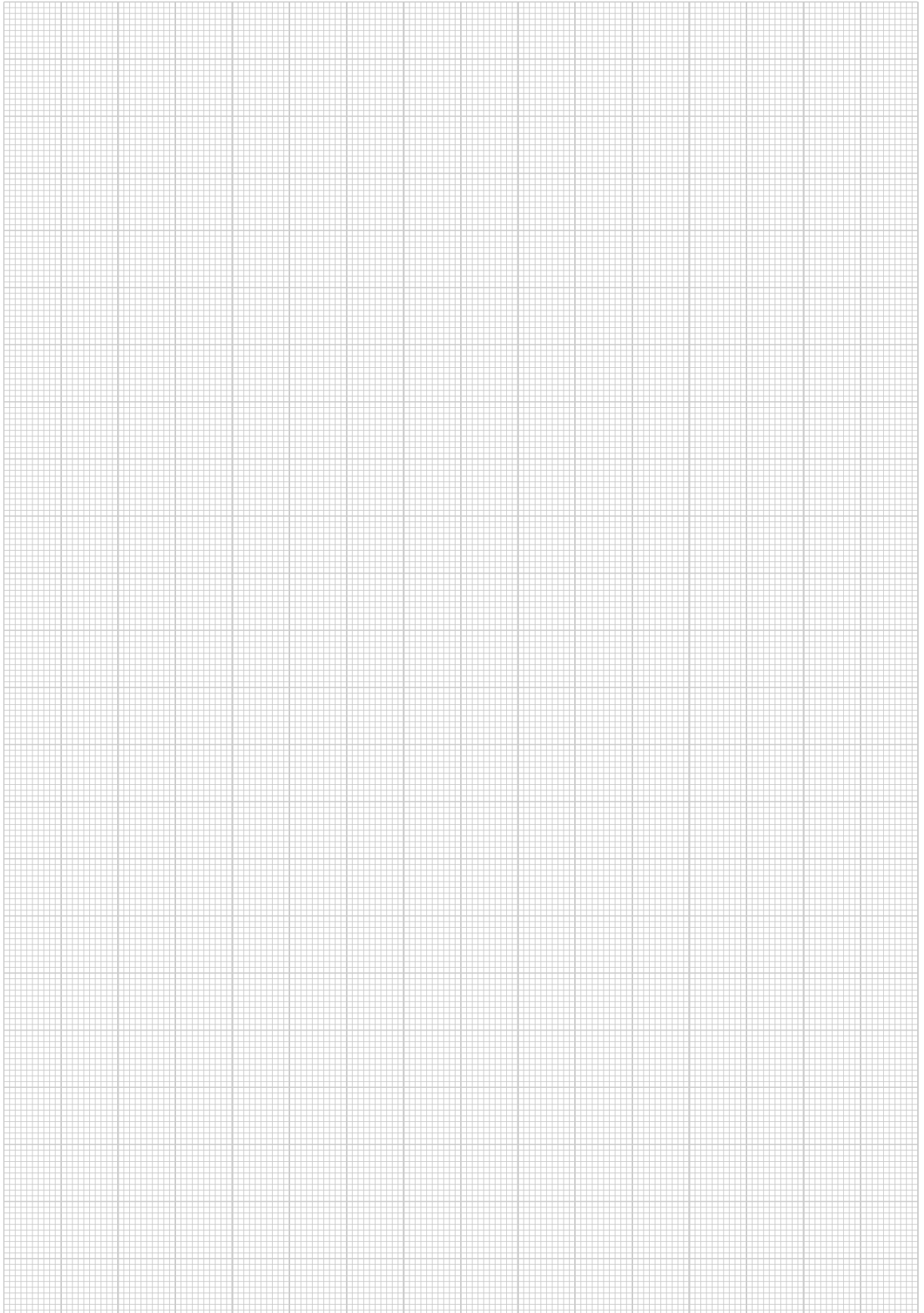

Notes

