

SLIDE UNIT

SLIDE GUIDE

BALL SPLINE
ROTARY BALL SPLINE
STROKE BALL SPLINE

TOPBALL® PRODUCTS

SLIDE BUSH

SLIDE UNIT

STROKE BUSH
SLIDE ROTARY BUSH

SLIDE SHAFT

SLIDE WAY/GONIO WAY
SLIDE TABLE
MINIATURE SLIDE

ACTUATOR

SLIDE SCREW

SLIDE UNIT

A wide variety of linear motion slide units are available. Their high precision blocks increase the accuracy of machinery and other equipment. The blocks can be constructed of resin to reduce cost and weight. The use of standard shaft end supports and shaft support rails simplifies the components. The use of commercial units help to reduce design time and installation and component costs.

TYPES

Table E-1





types		description		shaft support type	page
metric series	block type	SMA	 <p>housing material : aluminum alloy commonly used standard type inner contact diameter : $\phi 3\sim 60$</p>	SH-A SH SHF	P.E-8
		SMA-W	 <p>double wide housing material : aluminum alloy inner contact diameter : $\phi 3\sim 60$</p>		P.E-10
		AK	 <p>compact type housing material : aluminum alloy inner contact diameter : $\phi 6\sim 30$</p>		P.E-12
		AK-W	 <p>compact type double wide housing material : aluminum alloy inner contact diameter : $\phi 6\sim 30$</p>		P.E-14
		SMB	 <p>housing material : aluminum alloy inner contact diameter : $\phi 13\sim 40$</p>		P.E-16

Table E-2

types		description		shaft support type	page	
metric series	block type	RB 	light weight housing material : resin cost effective inner contact diameter : $\phi 10\sim 20$	SH-A SH SHF	P.E-28	
	pillow block type	SMP 	self-aligning feature housing material : cast iron inner contact diameter : $\phi 13\sim 60$		P.E-18	
	adjustable type	SMJ 	clearance adjustable housing material : aluminum alloy inner contact diameter : $\phi 10\sim 60$		P.E-20	
	open type	SME		open type housing material : aluminum alloy suitable for a long distance application inner contact diameter : $\phi 10\sim 50$	SA	P.E-22
		SME-W		open type double wide moment resistant housing material : aluminum alloy inner contact diameter : $\phi 10\sim 30$		P.E-24
		SMD		open type clearance adjustable housing material : aluminum alloy inner contact diameter : $\phi 16\sim 30$		P.E-26

Table E-3











types		description		page
metric series	shaft supporter	SH-A 	shaft end supporter material : aluminum alloy (SH-A), cast iron (SH) inner contact diameter : $\phi 8\sim 60$ (SH-A), $\phi 10\sim 60$ (SH)	P.E-29
		SH 		P.E-30
		SHF/SHF-FC 		shaft end supporter flanged type material : aluminum alloy (SHF 10-60) cast iron (SHF-FC 35-60) inner contact diameter : $\phi 10\sim 60$
	shaft support rail	SA 	shaft support rail for open type block material : aluminum alloy maximum length : 600mm inner contact diameter : $\phi 10\sim 50$	P.E-32
	assembly	CE(compact type) 	open type block and support rail assembly easy installation cost performance available clearance adjustable type and compact block type standard maximum length : 2,000mm longer length are available Please contact NB in case of the length exceeds 2,000mm inner contact diameter : $\phi 16\sim 30$	P.E-34
		CD(adjustable type) 		P.E-36

Table E-4

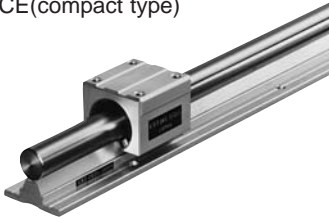
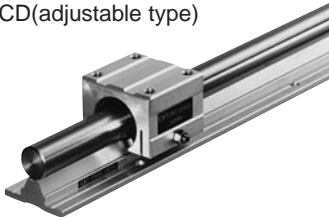
types		description		shaft support type	page
inch series	block type	SWA 	housing material : aluminum alloy inner contact diameter : $\phi 1/4" \sim 2"$	WH-A	PE-38
	adjustable type	SWJ 	clearance adjustable housing material : aluminum alloy inner contact diameter : $\phi 1/2" \sim 2"$		PE-40
	open type	SWD 	open type clearance adjustable housing material : aluminum alloy inner contact diameter : $\phi 1/2" \sim 2"$	WA	PE-42
	resin block type	RBW 	anti-corrosion light weight housing material : resin cost effective inner contact diameter : $\phi 1/2" \sim 1"$	WH-A	PE-44
	shaft supporter	WH-A 	shaft end supporter material : aluminum alloy inner contact diameter : $\phi 1/4" \sim 2"$	-	PE-45
	shaft support rail	WA 	shaft support rail for open type block material : aluminum alloy maximum length : 24" inner contact diameter : $\phi 1/2" \sim 2"$		PE-46

See C-1 TOPBALL PRODUCTS.

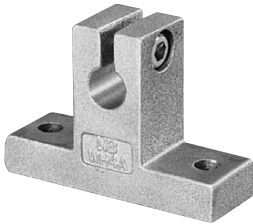
ACCURACY

The accuracy of the SA type and CE/CD-types support rails are measured as shown in Figure E-1.

Figure E-1 Measurement Method

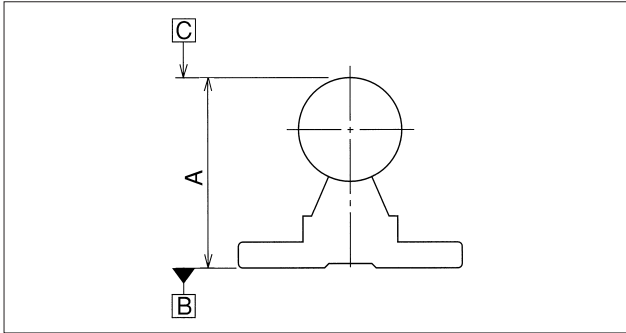

Figure E-2 Accuracy of SA Type Support

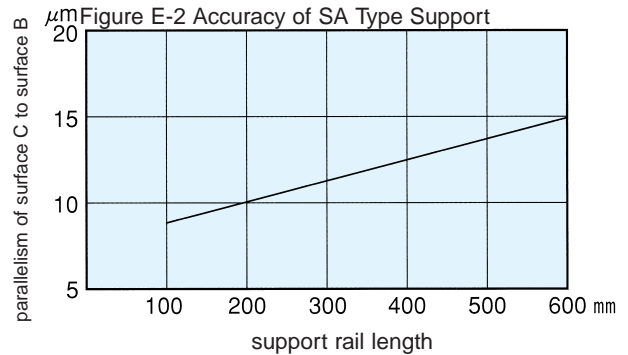
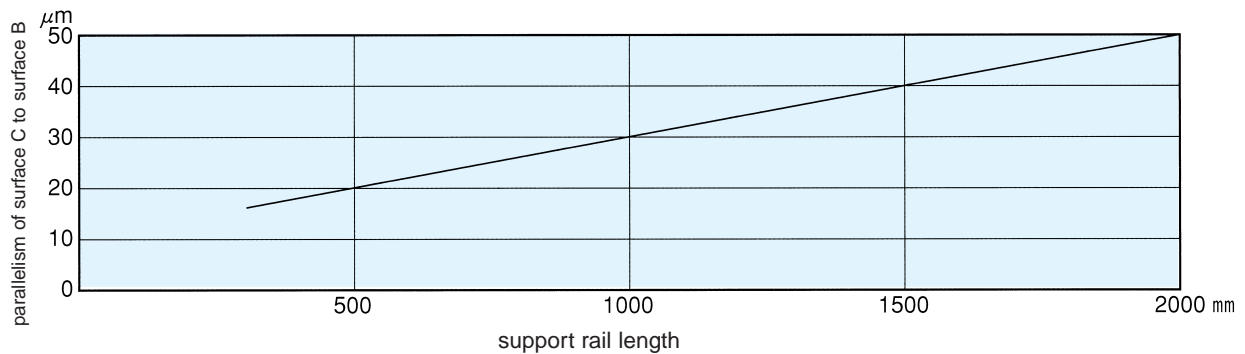

Figure E-3 Accuracy of CE/CD-Type Support Rails



LIFE

The life of a slide unit is estimated using the following equations, which are similar to that of a slide bushing.

Travel life:

$$L = \left(\frac{f_H \cdot f_T \cdot f_C}{f_W} \cdot \frac{C}{P} \right)^3 \cdot 50$$

L : travel life (km) f_H : hardness coefficient f_T : temperature coefficient
 f_C : contact coefficient f_W : load coefficient C : dynamic load rating(N)
 P : applied load(N)

※ When an open-type slide unit is used with the load in the direction shown in Figure E-4, the load rating must be calibrated using the coefficients listed in Table E-5.

Table E-5 Calibration Coefficients for Load Rating

part number		coefficient
SME(D)10G-16G	CE(D)16G	0.64
SME(D)20G	CE(D)20G	0.54
SME(D)25G-50G	CE(D)25G-30G	0.57

Contact NB for information on using steel retainers.

Life time:

$$L_h = \frac{L \cdot 10^3}{2 \cdot l_s \cdot n_1 \cdot 60}$$

L_h : life time(hr) l_s : stroke distance (m)
 n_1 : stroke frequency per min. (cpm)

Figure E-4 Load Direction

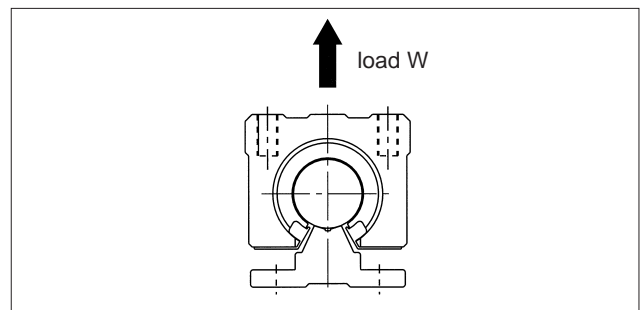

NOTES ON USAGE

Reference Surface:

A reference surface is provided with NB slide units as a standard feature. Excellent accuracy can be achieved by simply pushing the reference surface against the shoulder of the installation surface. (Excludes RB/RBW/SMP types)

Clearance Adjustment:

The adjustment of pre-load for the slide unit must be done carefully so that pre-load is not excessive. Care should be taken not to apply excessive torque when tightening the screws.

Mounting of RB Type Unit:

RB type unit has a resin housing. Mounting should be done using the proper torque values given in Table E-6.

Recommended Fit:

A standard grade slide bush is installed in NB slide units. For clearance and transition fit, g6 and h6 tolerance shafts, respectively, should be used. (Excludes adjustable-clearance type and open type)

Example: Special Installation Case of SMJ Type Slide Unit

When installing a Clearance Adjustable Unit such as illustrated in Figure D-6, please consult with NB. Special mounting holes will be required to allow for installations such as this.

Figure E-5 Reference Surface

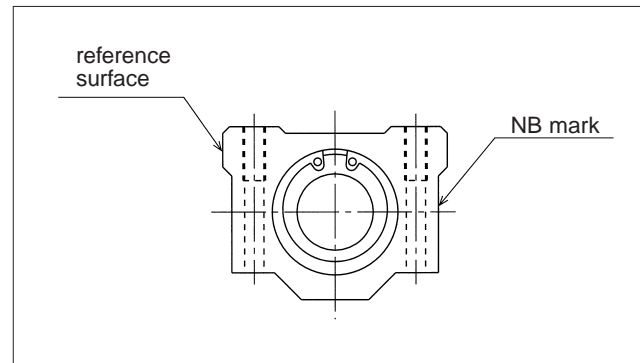
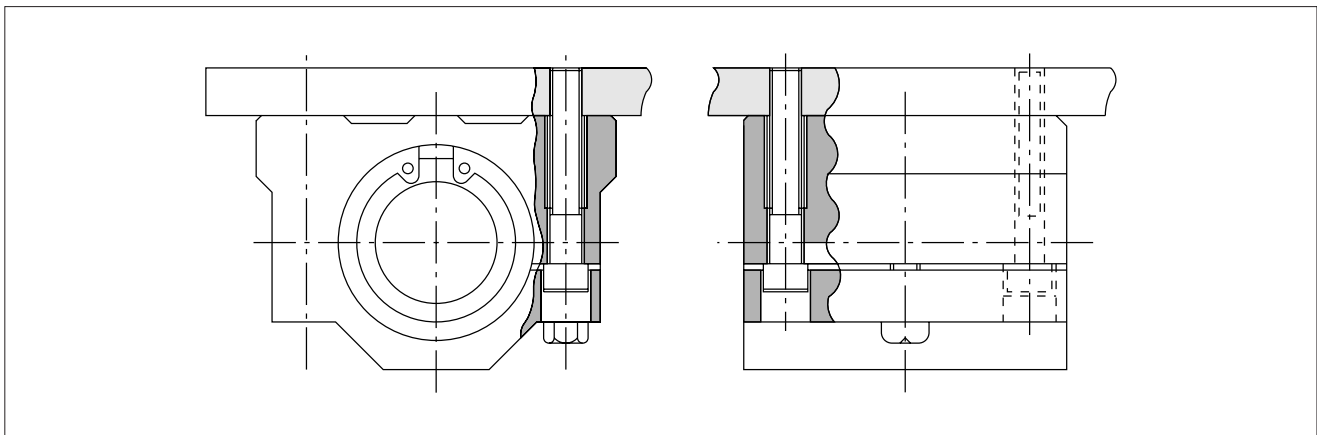

Table E-6 Torque Values

part number	mounting bolt	torque N-m
RB10~16	M4	1.8
RB20	M5	5.3

Figure D-6 Example: Special Installation Case of SMJ Type Slide Unit



SMA TYPE

– Block Type –

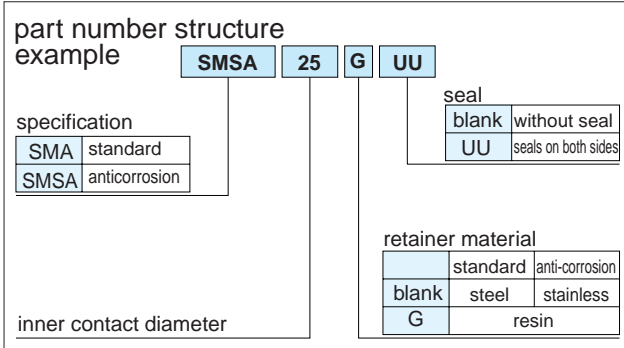

part number	major dimensions									
	inner contact diameter		outer dimensions							
	mm	tolerance μm	h mm	E mm	W mm	L mm	F mm	G mm	T mm	
SMA 3GUU	3	0	5	8	16	13	10	8	—	
SMA 4GUU	4	- 8	5.5	8.5	17	15	11	9	—	
SMA 5GUU	5		7	11	22	18	14	11	—	
SMA 6GUU	6	0	9	15	30	25	18	15	6	
SMA 8GUU	8		11	17	34	30	22	18	6	
SMA10GUU	10		13	20	40	35	26	21	8	
SMA12GUU	12		- 9	15	21	42	36	28	24	8
SMA13GUU	13		15	22	44	39	30	24.5	8	
SMA16GUU	16		19	25	50	44	38.5	32.5	9	
SMA20GUU	20	0	21	27	54	50	41	35	11	
SMA25GUU	25	-10	26	38	76	67	51.5	42	12	
SMA30GUU	30		30	39	78	72	59.5	49	15	
SMA35GUU	35	0	34	45	90	80	68	54	18	
SMA40GUU	40	-12	40	51	102	90	78	62	20	
SMA50GUU	50		52	61	122	110	102	80	25	
SMA60GUU	60		0/-15	58	66	132	122	114	94	30

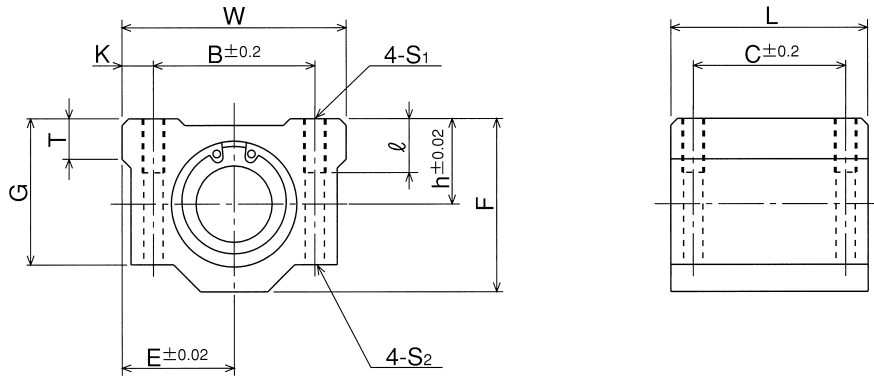

mounting dimensions						basic load rating		mass g	part number
						dynamic C N	static Co N		
B mm	C mm	K mm	S ₁	ℓ mm	S ₂ mm				
11	8	2.5	M 2	—	—	69	105	5	SMA 3GUU
12	10	2.5	M 3	—	—	88	127	7	SMA 4GUU
16	12	3	M 3	—	—	167	206	14	SMA 5GUU
20	15	5	M 4	8	3.4	206	265	34	SMA 6GUU
24	18	5	M 4	8	3.4	274	392	52	SMA 8GUU
28	21	6	M 5	12	4.3	372	549	92	SMA10GUU
30.5	26	5.75	M 5	12	4.3	510	784	102	SMA12GUU
33	26	5.5	M 5	12	4.3	510	784	120	SMA13GUU
36	34	7	M 5	12	4.3	774	1,180	200	SMA16GUU
40	40	7	M 6	12	5.2	882	1,370	255	SMA20GUU
54	50	11	M 8	18	7	980	1,570	600	SMA25GUU
58	58	10	M 8	18	7	1,570	2,740	735	SMA30GUU
70	60	10	M 8	18	7	1,670	3,140	1,100	SMA35GUU
80	60	11	M10	25	8.7	2,160	4,020	1,590	SMA40GUU
100	80	11	M10	25	8.7	3,820	7,940	3,340	SMA50GUU
108	90	12	M12	25	10.7	4,700	10,000	4,270	SMA60GUU

1N ≅ 0.102kgf

SMA-W TYPE

– Double-Wide Block Type –

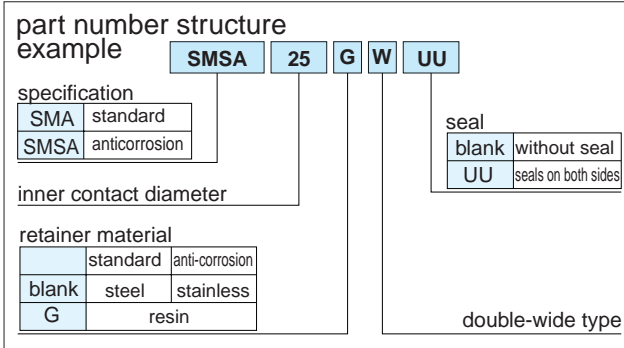
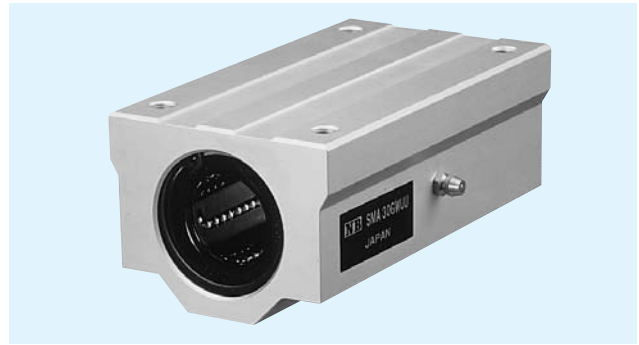

part number	major dimensions									
	inner contact diameter		outer dimensions							
	mm	tolerance μm	h mm	E mm	W mm	L mm	F mm	G mm	T mm	N mm
SMA 3GWUU	3	0	5	8	16	23	10	8	—	—
SMA 4GWUU	4	— 8	5.5	8.5	17	27	11	9	—	—
SMA 5GWUU	5		7	11	22	33	14	11	—	—
SMA 6GWUU	6		9	15	30	48	18	15	6	7
SMA 8GWUU	8		11	17	34	58	22	18	6	7
SMA10GWUU	10	0	13	20	40	68	26	21	8	7
SMA12GWUU	12	— 9	15	21	42	70	28	24	8	6.5
SMA13GWUU	13		15	22	44	75	30	24.5	8	6.5
SMA16GWUU	16		19	25	50	85	38.5	32.5	9	6
SMA20GWUU	20	0	21	27	54	96	41	35	11	7
SMA25GWUU	25	— 10	26	38	76	130	51.5	42	12	4
SMA30GWUU	30		30	39	78	140	59.5	49	15	5
SMA35GWUU	35	0	34	45	90	155	68	54	18	5.5
SMA40GWUU	40	— 12	40	51	102	175	78	62	20	5
SMA50GWUU	50		52	61	122	215	102	80	25	5
SMA60GWUU	60	0/— 15	58	66	132	240	114	94	30	5

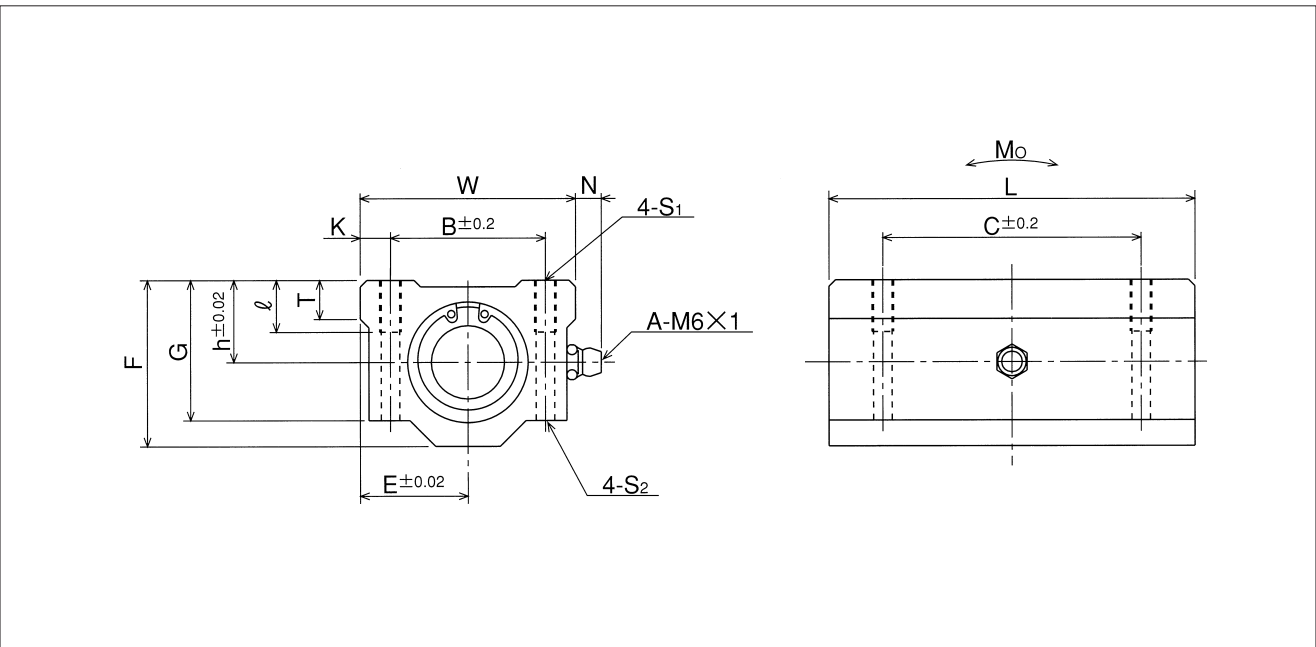

mounting dimensions						basic load rating		allowable static moment Mo N · m	mass g	part number
B mm	C mm	K mm	S ₁	ℓ mm	S ₂ mm	C N	Co N			
11	16	2.5	M 2	—	—	108	206	0.49	10	SMA 3GWUU
12	20	2.5	M 3	—	—	137	255	0.72	13	SMA 4GWUU
16	25	3	M 3	—	—	265	412	1.54	27	SMA 5GWUU
20	36	5	M 4	8	3.4	323	530	2.18	63	SMA 6GWUU
24	42	5	M 4	8	3.4	431	784	4.31	102	SMA 8GWUU
28	46	6	M 5	12	4.3	588	1,100	7.24	180	SMA10GWUU
30.5	50	5.75	M 5	12	4.3	813	1,570	10.9	205	SMA12GWUU
33	50	5.5	M 5	12	4.3	813	1,570	11.6	240	SMA13GWUU
36	60	7	M 5	12	4.3	1,230	2,350	19.7	400	SMA16GWUU
40	70	7	M 6	12	5.2	1,400	2,740	26.8	570	SMA20GWUU
54	100	11	M 8	18	7	1,560	3,140	43.4	1,200	SMA25GWUU
58	110	10	M 8	18	7	2,490	5,490	82.8	1,480	SMA30GWUU
70	120	10	M 8	18	7	2,650	6,270	110	2,200	SMA35GWUU
80	140	11	M10	25	8.7	3,430	8,040	147	3,200	SMA40GWUU
100	160	11	M10	25	8.7	6,080	15,900	397	6,700	SMA50GWUU
108	180	12	M12	25	10.7	7,550	20,000	530	8,560	SMA60GWUU

1N≐0.102kgf 1N·m≐0.102kgf·m

AK TYPE

— Compact Block Type —

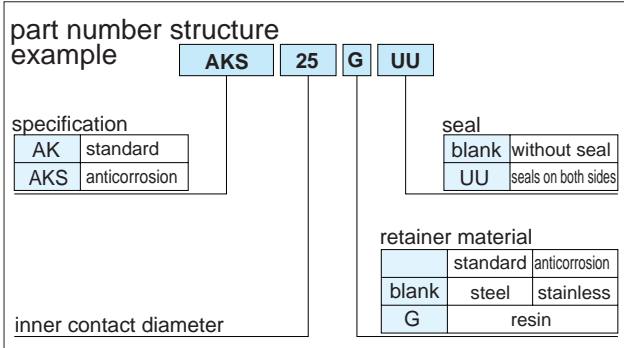

part number	major dimensions								
	inner contact diameter		outer dimensions						
	mm	tolerance μm	h mm	E mm	W mm	L mm	F mm	L ₂ mm	S ₁
AK 6GUU	6	- 9	14	8	16	27	22	18	M 4
AK 8GUU	8		16	10	20	32	26	20	M 5
AK10GUU	10		19	13	26	39	32	27	M 6
AK12GUU	12		20	14	28	40	34	27	M 6
AK13GUU	13		25	15	30	42	43	28	M 6
AK16GUU	16		27	18	36	47	49	32	M 6
AK20GUU	20	- 10	31	21	42	52	54	36	M 8
AK25GUU	25		37	26	52	69	65	42	M10
AK30GUU	30		40	29	58	74	71	44	M10

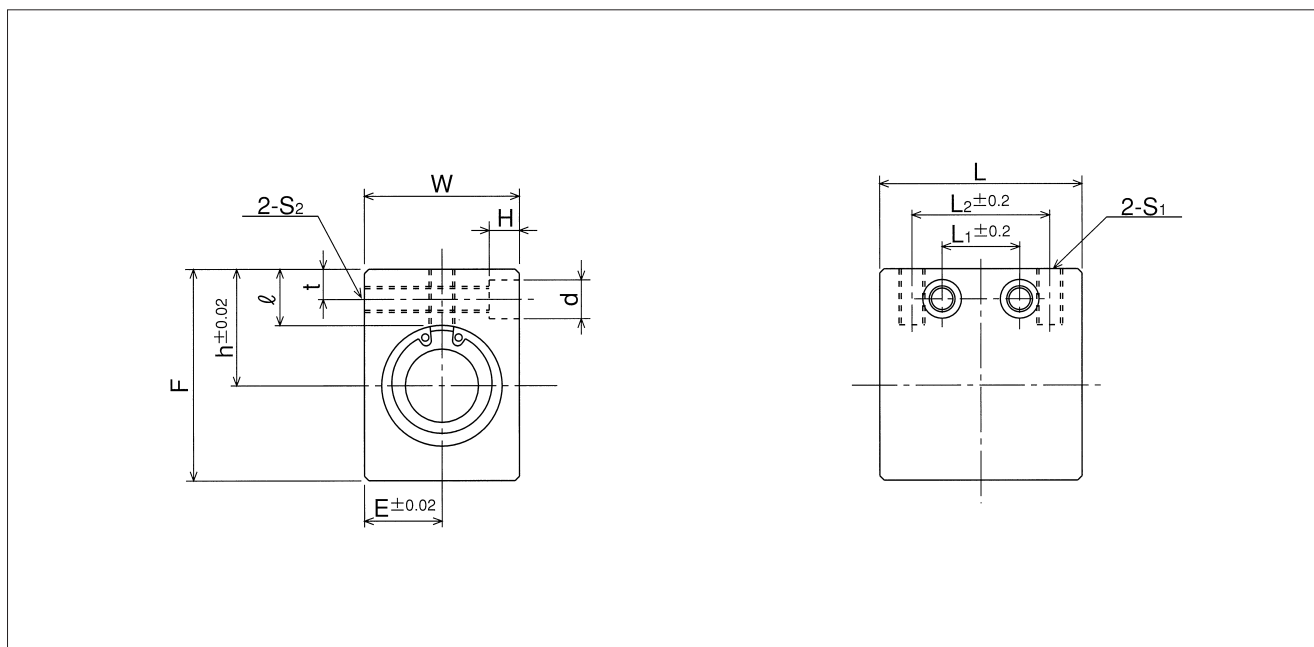

mounting dimensions						basic load rating		mass g	part number
						dynamic C N	static Co N		
ℓ mm	L_1 mm	t mm	S_2	d mm	H mm				
8	9	5	M 4	6	5	206	265	21.5	AK 6GUU
8.5	10	5	M 4	6	5	274	392	40	AK 8GUU
9.5	15	6	M 5	8	6	372	549	80	AK10GUU
9.5	15	6	M 5	8	6	510	784	90	AK12GUU
13.5	16	7	M 6	9	7	510	784	132	AK13GUU
13	18	7	M 6	9	7	774	1,180	204	AK16GUU
15	18	8	M 8	11	8	882	1,370	272	AK20GUU
17	22	9	M10	14	10	980	1,570	574	AK25GUU
17.5	22	9	M10	14	10	1,570	2,740	710	AK30GUU

1N \approx 0.102kgf

AK-W TYPE

– Double-Wide Compact Block Type –

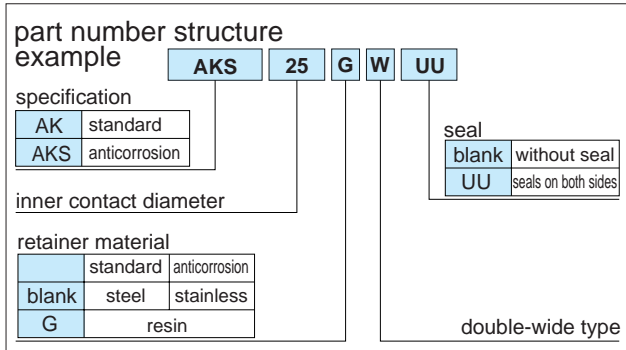
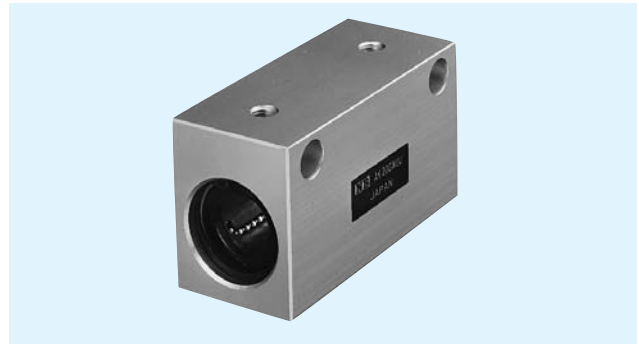

part number	major dimensions									
	inner contact diameter		outer dimensions							
	mm	tolerance μm	h mm	E mm	W mm	L mm	F mm	L ₂ mm	S ₁	ℓ mm
AK 6GWUU	6	0 - 9	14	8	16	46	22	20	M 4	8
AK 8GWUU	8		16	10	20	56	26	30	M 5	8.5
AK10GWUU	10		19	13	26	68	32	36	M 6	9.5
AK12GWUU	12		20	14	28	70	34	36	M 6	9.5
AK13GWUU	13		25	15	30	74	43	42	M 6	13.5
AK16GWUU	16	27	18	36	84	49	52	M 6	13	
AK20GWUU	20	0 - 10	31	21	42	94	54	58	M 8	15
AK25GWUU	25		37	26	52	128	65	80	M10	17
AK30GWUU	30		40	29	58	138	71	90	M10	17.5

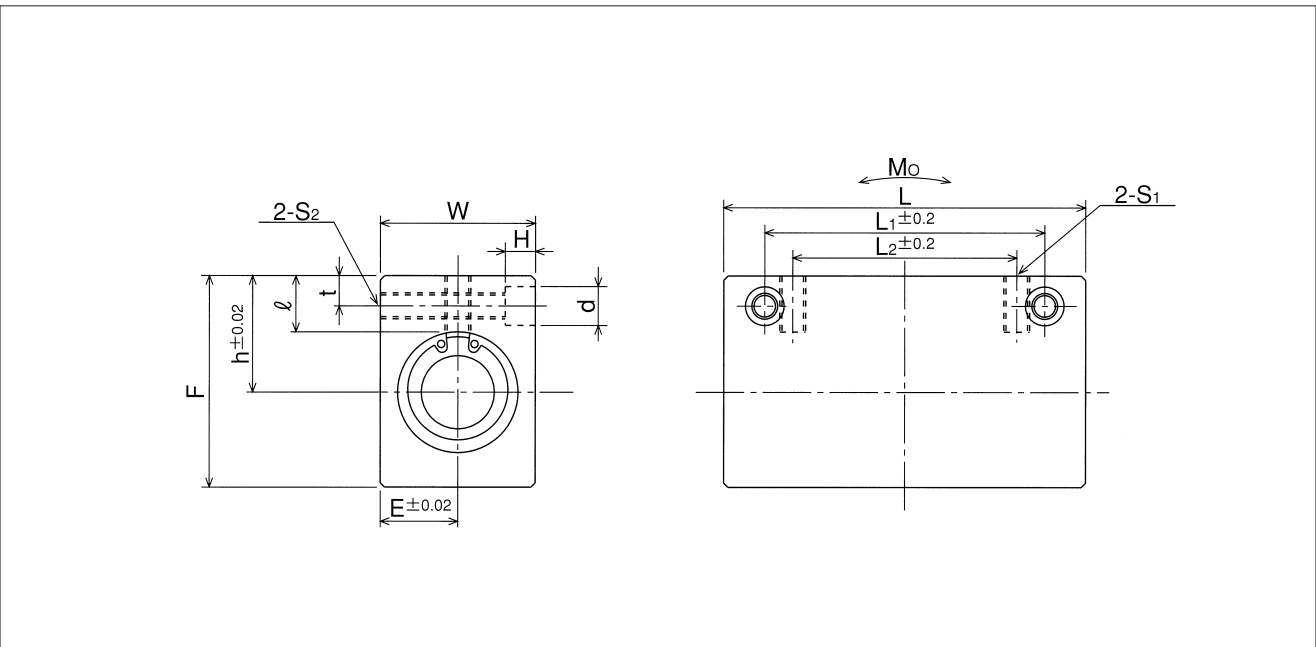

mounting dimensions					basic load rating		allowable static moment M_o N · m	mass g	part number
					dynamic C N	static C_o N			
L_1 mm	t mm	S_2	d mm	H mm					
30	5	M 4	6	5	323	530	2.18	40	AK 6GWUU
42	5	M 4	6	5	431	784	4.31	75	AK 8GWUU
50	6	M 5	8	6	588	1,100	7.24	150	AK10GWUU
50	6	M 5	8	6	813	1,570	10.9	168	AK12GWUU
55	7	M 6	9	7	813	1,570	11.6	248	AK13GWUU
65	7	M 6	9	7	1,230	2,350	19.7	383	AK16GWUU
70	8	M 8	11	8	1,400	2,740	26.8	520	AK20GWUU
100	9	M10	14	10	1,560	3,140	43.4	1,120	AK25GWUU
110	9	M10	14	10	2,490	5,490	82.8	1,384	AK30GWUU

1N \approx 0.102kgf 1N·m \approx 0.102kgf·m

SMB TYPE

– Block Type –

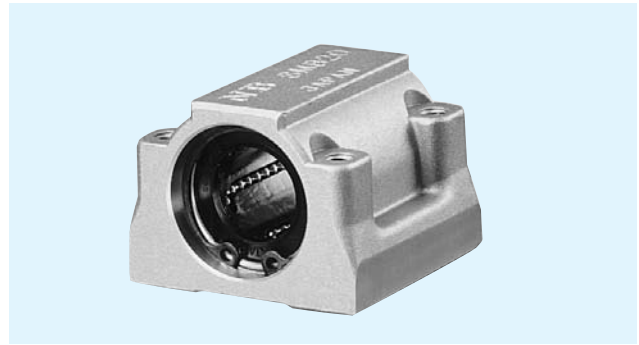

part number structure		example		SMSB	25	G	UU
specification						seal	
SMB	standard					blank	without seal
SMSB	anticorrosion					UU	seals on both sides
inner contact diameter						retainer material	
				blank	standard	anticorrosion	
				G	resin		

part number	major dimensions								
	inner contact diameter		outer dimensions						
	mm	tolerance μm	h mm	E mm	W mm	L mm	F mm	G mm	T mm
SMB13GUU	13	0	16	22	44	39	31	22	8
SMB16GUU	16	-9	19	25	50	49	37	28	9
SMB20GUU	20	0	21	27	54	55	41	31	11
SMB25GUU	25	-10	26	38	76	73	51	38	12
SMB30GUU	30	-10	30	39	78	80	57	45	15
SMB40GUU	40	0/-12	40	51	102	96	75	59	22

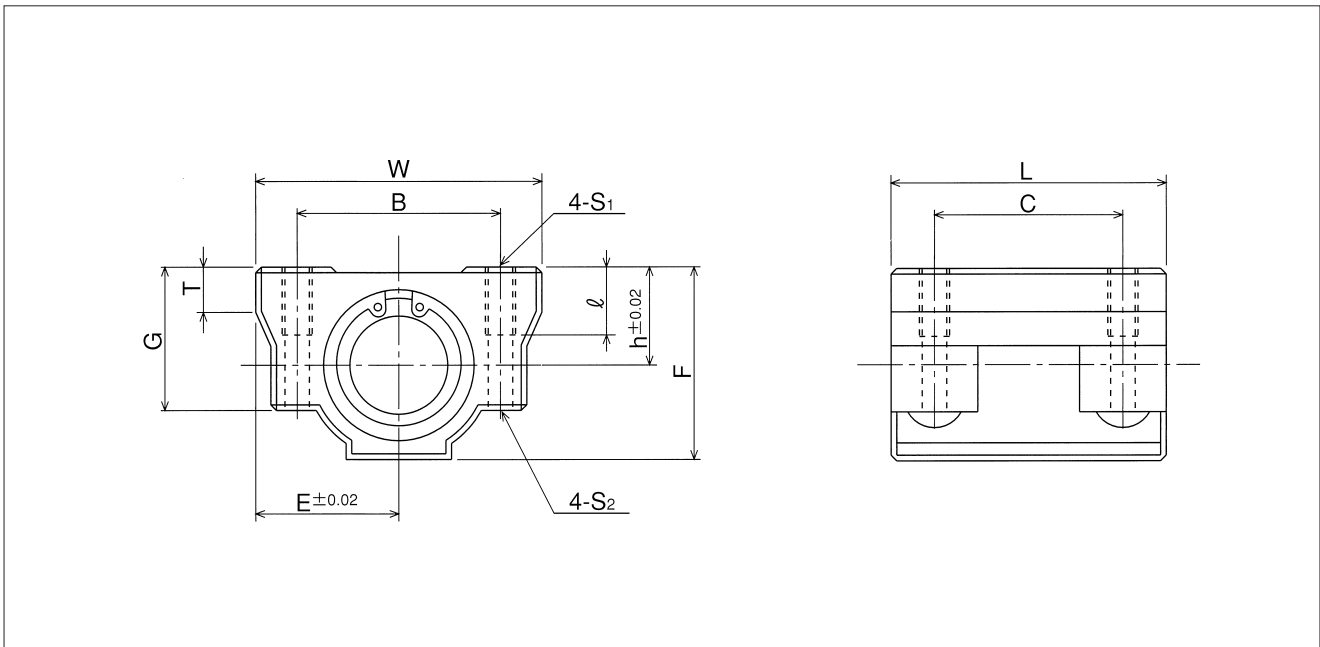

mounting dimensions					basic load rating		mass g	part number
					dynamic C N	static Co N		
B mm	C mm	S ₁	ℓ mm	S ₂ mm				
33	26	M 5	10	4.3	510	784	120	SMB13GUU
36	34	M 5	12	4.3	774	1,180	170	SMB16GUU
40	40	M 6	12	5.1	882	1,370	210	SMB20GUU
54	50	M 8	18	6.8	980	1,570	500	SMB25GUU
58	58	M 8	18	6.8	1,570	2,740	600	SMB30GUU
80	60	M10	25	8.6	2,160	4,020	1,200	SMB40GUU

1N ≅ 0.102kgf

SMP TYPE

– Pillow Block Type –

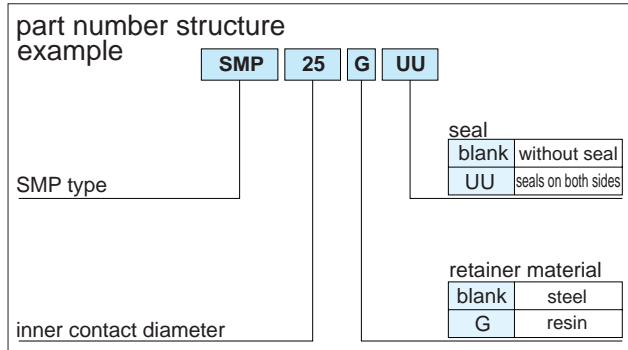
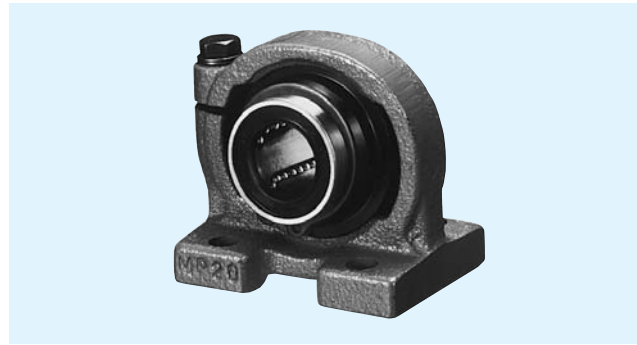

part number	major dimensions								
	inner contact diameter		outer dimensions						
	mm	tolerance μm	h mm	E mm	W mm	L mm	F mm	G mm	M mm
SMP13GUU	13	0	25	25	50	32	46	8	36
SMP16GUU	16	-9	29	27.5	55	37	53	10	40
SMP20GUU	20	0	34	32.5	65	42	62	12	48
SMP25GUU	25	-10	40	38	76	59	73	12	59
SMP30GUU	30	-10	45	42.5	85	64	84	15	69
SMP35GUU	35	0	50	49	98	70	94	15	76
SMP40GUU	40	-12	60	62	124	80	112	18	86
SMP50GUU	50	-12	70	72	144	100	134	20	105
SMP60GUU	60	0/-15	82	84.5	169	110	154	23	115

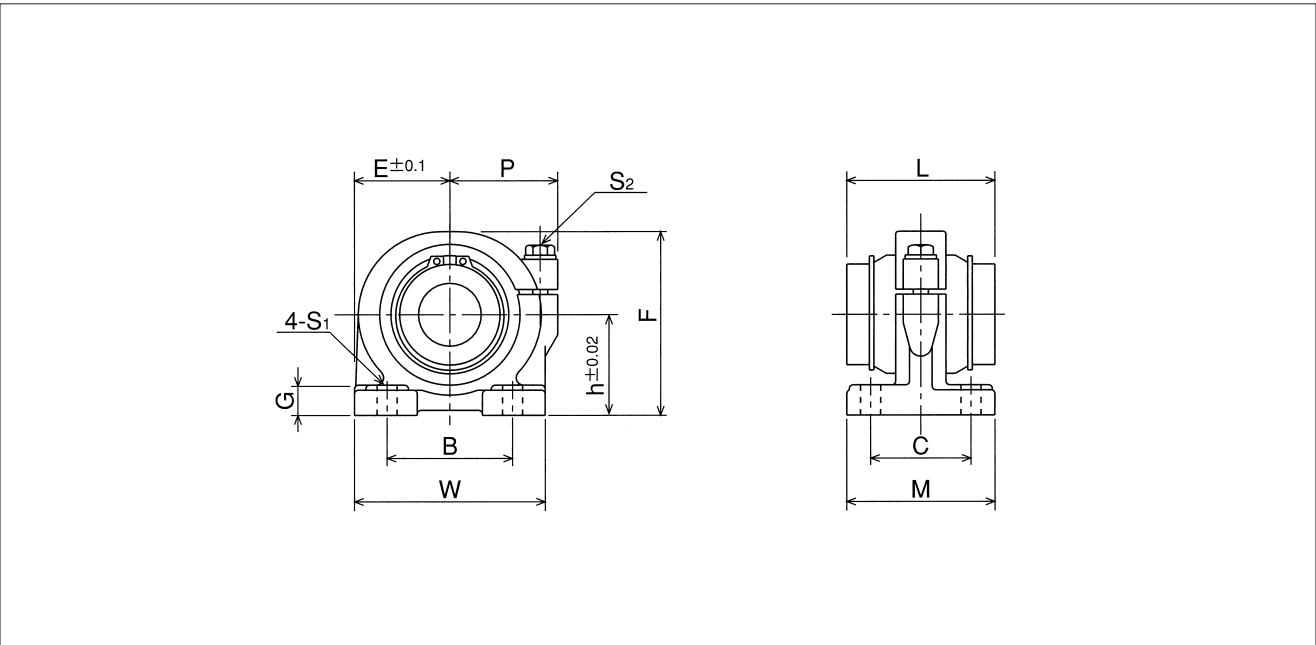

P mm	mounting dimensions			adjustment bolt size S_2	basic load rating		mass g	part number
	B mm	C mm	S_1 (bolt size) mm		dynamic C N	static C_0 N		
30	30	26	7(M 5)	M 5	510	784	270	SMP13GUU
32	35	29	7(M 5)	M 5	774	1,180	380	SMP16GUU
37	40	35	8(M 6)	M 6	882	1,370	680	SMP20GUU
43	50	40	8(M 6)	M 6	980	1,570	1,000	SMP25GUU
49	58	46	10(M 8)	M 8	1,570	2,740	1,400	SMP30GUU
58	62	53	12(M10)	M10	1,670	3,140	2,100	SMP35GUU
68	76	64	12(M10)	M10	2,160	4,020	3,700	SMP40GUU
80	100	70	14(M12)	M12	3,820	7,940	6,100	SMP50GUU
88	115	80	14(M12)	M12	4,700	10,000	8,700	SMP60GUU

1N \approx 0.102kgf

SMJ TYPE

– Clearance Adjustable Type –

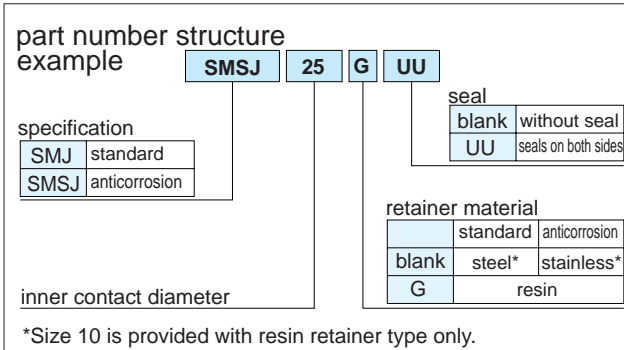
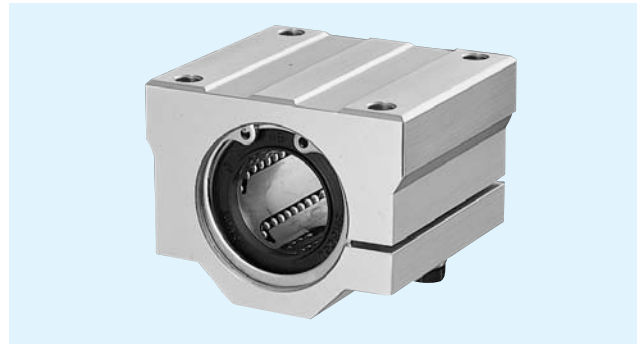

part number	major dimensions								
	inner contact diameter mm	outer dimensions							
		h mm	E mm	W mm	L mm	F mm	G mm	T mm	B mm
SMJ10GUU*	10	13	20	40	35	26	21	8	28
SMJ12GUU	12	15	21	42	36	28	24	8	30.5
SMJ13GUU	13	15	22	44	39	30	24.5	8	33
SMJ16GUU	16	19	25	50	44	38.5	32.5	9	36
SMJ20GUU	20	21	27	54	50	41	35	11	40
SMJ25GUU	25	26	38	76	67	51.5	42	12	54
SMJ30GUU	30	30	39	78	72	59.5	49	15	58
SMJ35GUU	35	34	45	90	80	68	54	18	70
SMJ40GUU	40	40	51	102	90	78	62	20	80
SMJ50GUU	50	52	61	122	110	102	80	25	100
SMJ60GUU	60	58	66	132	122	114	94	30	108

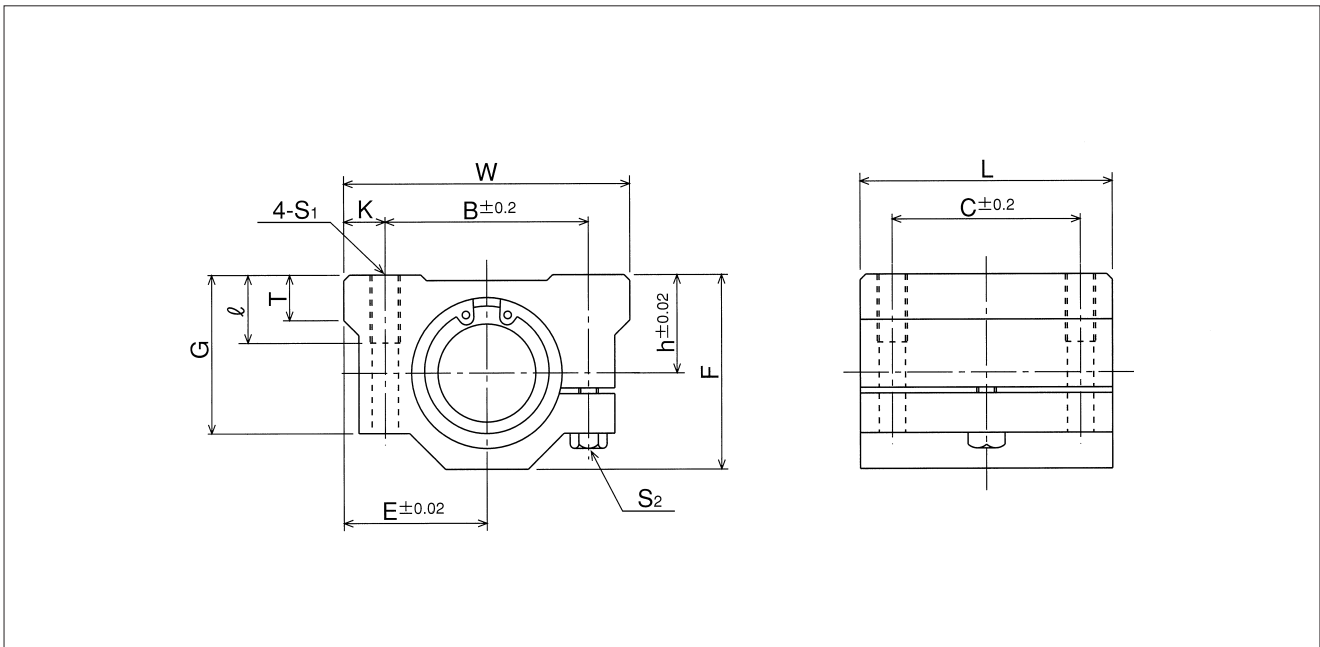

mounting dimensions				adjusting bolt size S_2	basic load rating		mass g	part number
C mm	K mm	S_1	ℓ mm		dynamic C N	static C_0 N		
21	6	M 5	12	M 4	372	549	92	SMJ10GUU
26	5.75	M 5	12	M 4	510	784	102	SMJ12GUU
26	5.5	M 5	12	M 4	510	784	120	SMJ13GUU
34	7	M 5	12	M 4	774	1,180	200	SMJ16GUU
40	7	M 6	12	M 5	882	1,370	255	SMJ20GUU
50	11	M 8	18	M 6	980	1,570	600	SMJ25GUU
58	10	M 8	18	M 6	1,570	2,740	735	SMJ30GUU
60	10	M 8	18	M 6	1,670	3,140	1,100	SMJ35GUU
60	11	M10	25	M 8	2,160	4,020	1,590	SMJ40GUU
80	11	M10	25	M 8	3,820	7,940	3,340	SMJ50GUU
90	12	M12	25	M10	4,700	10,000	4,270	SMJ60GUU

1N \approx 0.102kgf

SME TYPE

– Open Block Type –

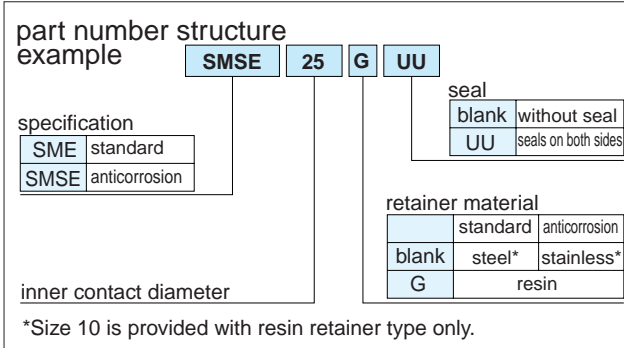

part number	major dimensions							
	inner contact diameter mm	h mm	E mm	W mm	L mm	F mm	T mm	h ₁ mm
SME10GUU*	10	15	18	36	32	24	7	6
SME13GUU	13	17	20	40	39	28	8	8.5
SME16GUU	16	20	22.5	45	45	33	9	10
SME20GUU	20	23	24	48	50	39	11	10
SME25GUU	25	27	30	60	65	47	14	11.5
SME30GUU	30	33	35	70	70	56	15	14
SME35GUU	35	37	40	80	80	63	18	16
SME40GUU	40	42	45	90	90	72	20	19
SME50GUU	50	53	60	120	110	92	25	23

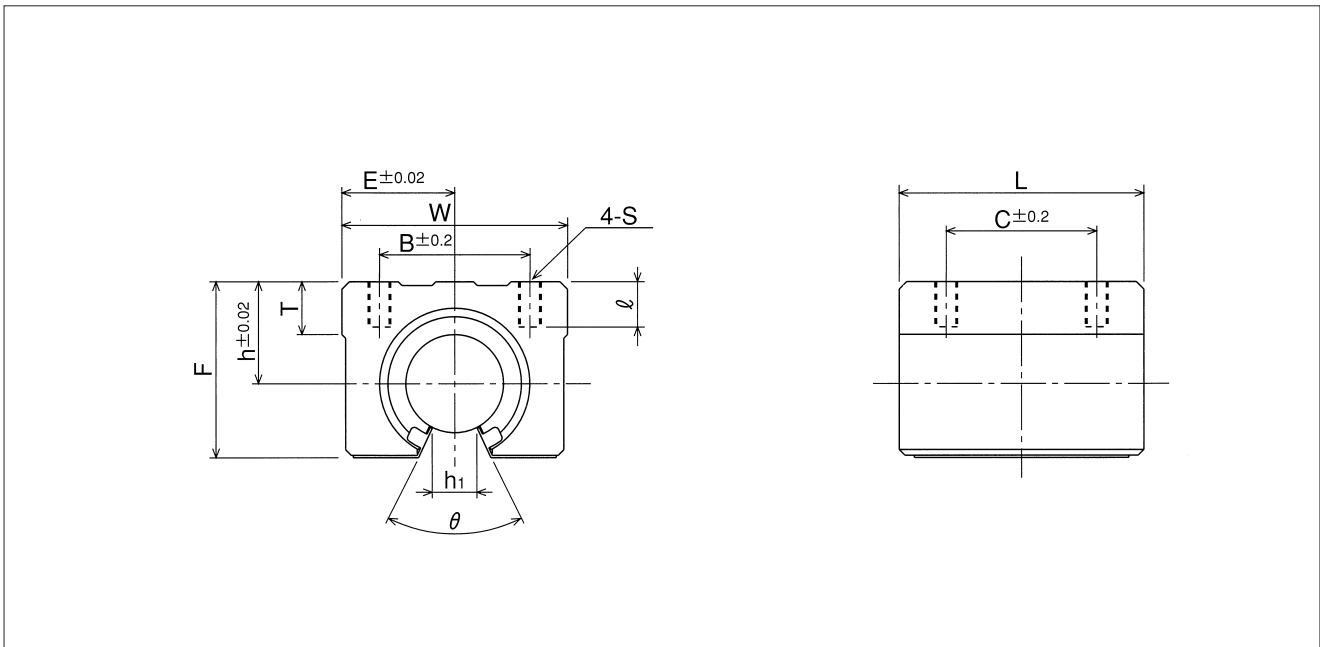

θ	mounting dimensions				basic load rating		mass g	part number
	B mm	C mm	S	ℓ mm	dynamic C N	static Co N		
80°	25	20	M 5	10	372	549	65	SME10GUU
80°	28	26	M 5	10	510	784	100	SME13GUU
80°	32	30	M 5	12	774	1,180	150	SME16GUU
60°	35	35	M 6	12	882	1,370	200	SME20GUU
50°	40	40	M 6	12	980	1,570	450	SME25GUU
50°	50	50	M 8	18	1,570	2,740	630	SME30GUU
50°	55	55	M 8	18	1,670	3,140	925	SME35GUU
50°	65	65	M10	20	2,160	4,020	1,330	SME40GUU
50°	94	80	M10	20	3,820	7,940	3,000	SME50GUU

1N≐0.102kgf

SME-W TYPE

– Double-wide Open Block Type –

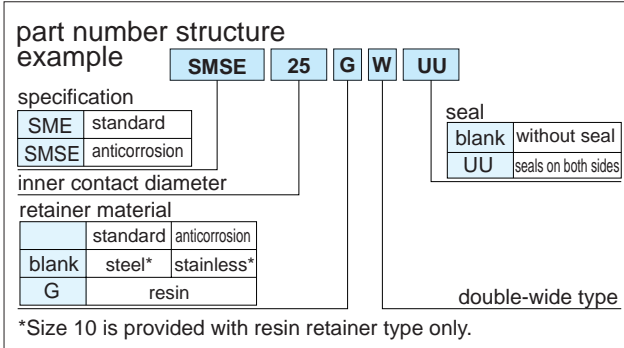

part number	major dimensions								
	inner contact diameter mm	outer dimensions							
		h mm	E mm	W mm	L mm	F mm	T mm	N mm	h ₁ mm
SME10GWUU*	10	15	18	36	65	24	7	7.5	6
SME13GWUU	13	17	20	40	75	28	8	7.5	8.5
SME16GWUU	16	20	22.5	45	85	33	9	7.5	10
SME20GWUU	20	23	24	48	95	39	11	7.5	10
SME25GWUU	25	27	30	60	130	47	14	7.5	11.5
SME30GWUU	30	33	35	70	140	56	15	7.5	14

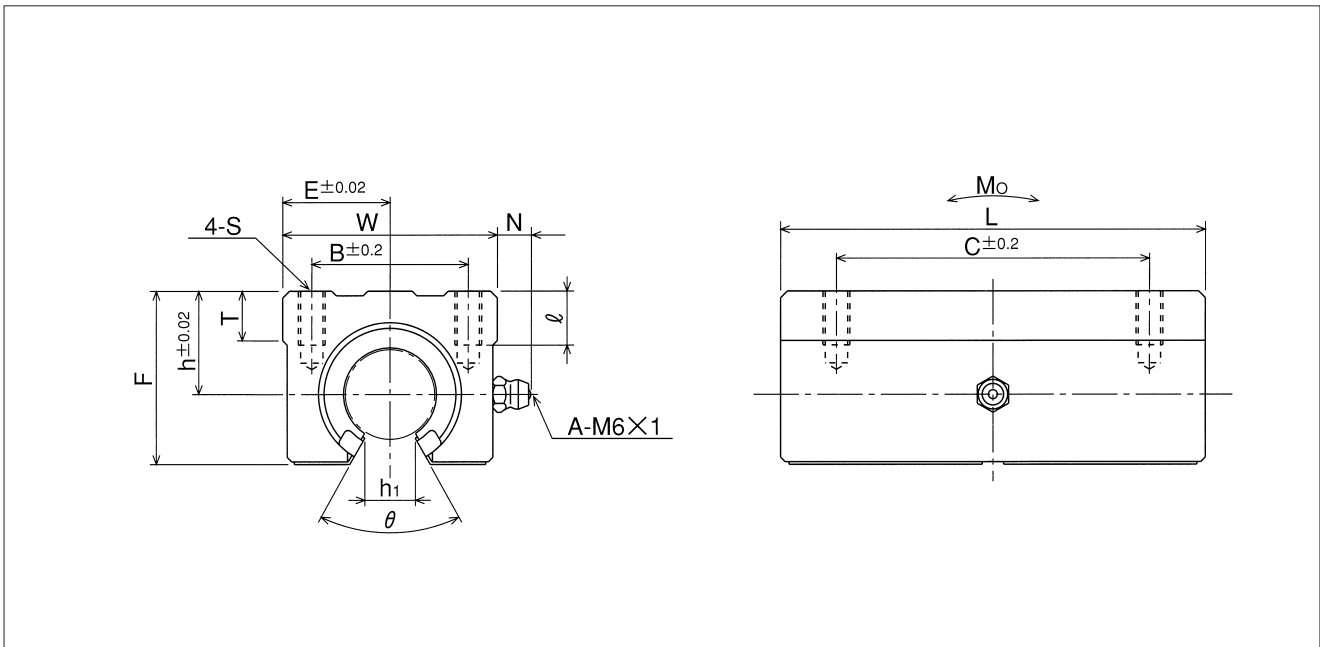

θ	mounting dimensions				basic load rating		allowable static moment M_o N·m	mass g	part number
	B mm	C mm	S	ℓ mm	dynamic C N	static C_o N			
80°	25	40	M5	10	588	1,100	4.63	140	SME10GWUU
80°	28	50	M5	10	813	1,570	7.42	200	SME13GWUU
80°	32	60	M5	12	1,230	2,350	12.6	300	SME16GWUU
60°	35	70	M6	12	1,400	2,740	14.5	400	SME20GWUU
50°	40	90	M6	12	1,560	3,140	24.7	900	SME25GWUU
50°	50	100	M8	18	2,490	5,490	47.2	1,260	SME30GWUU

1N \approx 0.102kgf 1N·m \approx 0.102kgf·m

SMD TYPE

— Open Block with Clearance Adjustable Type —

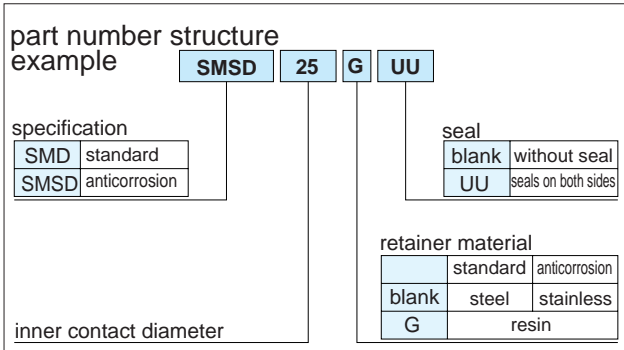

part number	major dimensions								
	inner contact diameter mm	outer dimensions							
		h mm	E mm	W mm	L mm	F mm	T mm	G mm	h ₁ mm
SMD16GUU	16	20	25	50	45	33	9	6	10
SMD20GUU	20	23	27	54	50	39	11	7	10
SMD25GUU	25	27	38	76	65	47	14	7	11.5
SMD30GUU	30	33	39	78	70	56	15	7	14

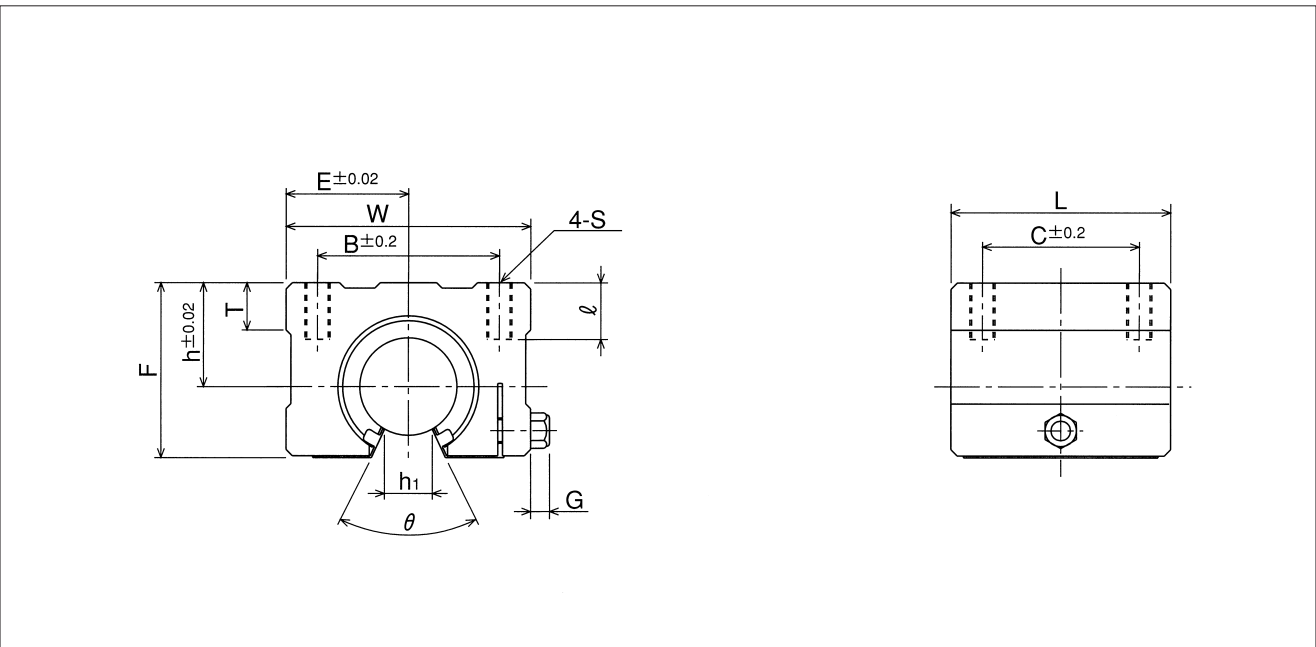

θ	mounting dimensions				basic load rating		mass g	part number
	B mm	C mm	S	l mm	dynamic C N	static Co N		
80°	36	30	M5	12	774	1,180	170	SMD16GUU
60°	40	35	M6	12	882	1,370	240	SMD20GUU
50°	54	40	M6	12	980	1,570	580	SMD25GUU
50°	58	50	M8	18	1,570	2,740	720	SMD30GUU

1N \approx 0.102kgf

SH-A TYPE

– Shaft End Supporter – (Aluminum)

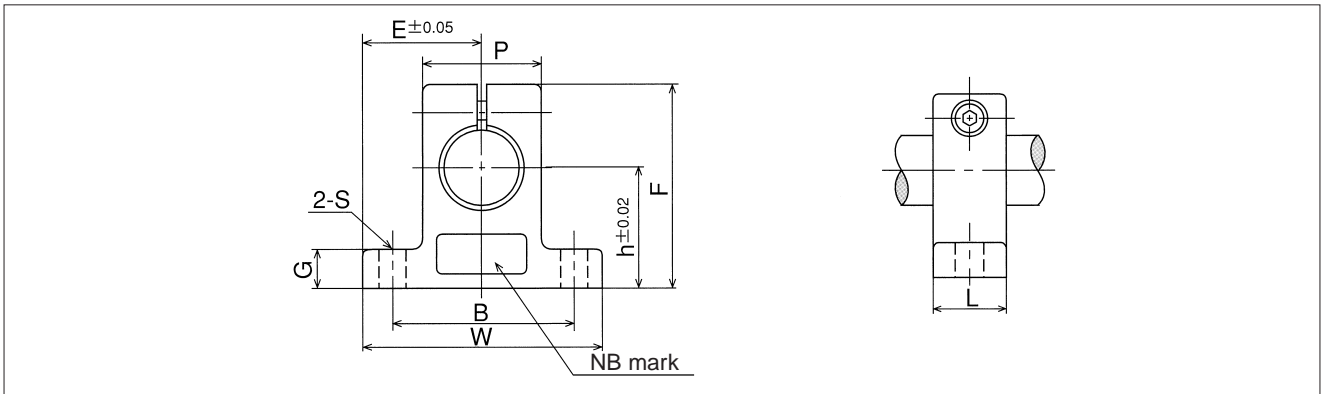
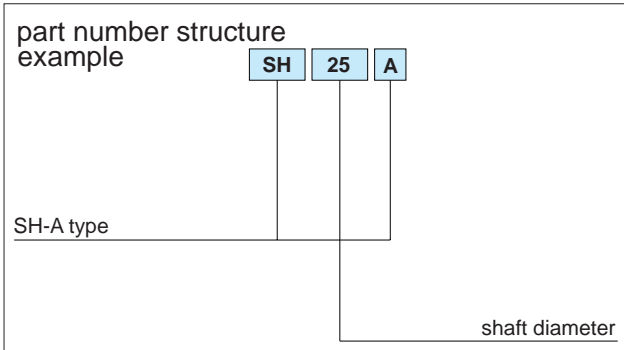

part number	shaft diameter mm	major dimensions									adjusting bolt size	mass g
		h mm	E mm	W mm	L mm	F mm	G mm	P mm	B mm	S (bolt size) mm		
SH 8A	8	20	21	42	14	32.8	6	18	32	5.5(M 5)	M 4	24
SH10A	10	20	21	42	14	32.8	6	18	32	5.5(M 5)	M 4	24
SH12A	12	23	21	42	14	37.5	6	20	32	5.5(M 5)	M 4	30
SH13A	13	23	21	42	14	37.5	6	20	32	5.5(M 5)	M 4	30
SH16A	16	27	24	48	16	44	8	25	38	5.5(M 5)	M 4	40
SH20A	20	31	30	60	20	51	10	30	45	6.6(M 6)	M 5	70
SH25A	25	35	35	70	24	60	12	38	56	6.6(M 6)	M 6	130
SH30A	30	42	42	84	28	70	12	44	64	9 (M 8)	M 6	180
SH35A	35	50	49	98	32	82	15	50	74	11 (M10)	M 8	270
SH40A	40	60	57	114	36	96	15	60	90	11 (M10)	M 8	420
SH50A	50	70	63	126	40	120	18	74	100	14 (M12)	M12	750
SH60A	60	80	74	148	45	136	18	90	120	14 (M12)	M12	1,100

SH TYPE

– Shaft End Supporter – (Cast Iron)

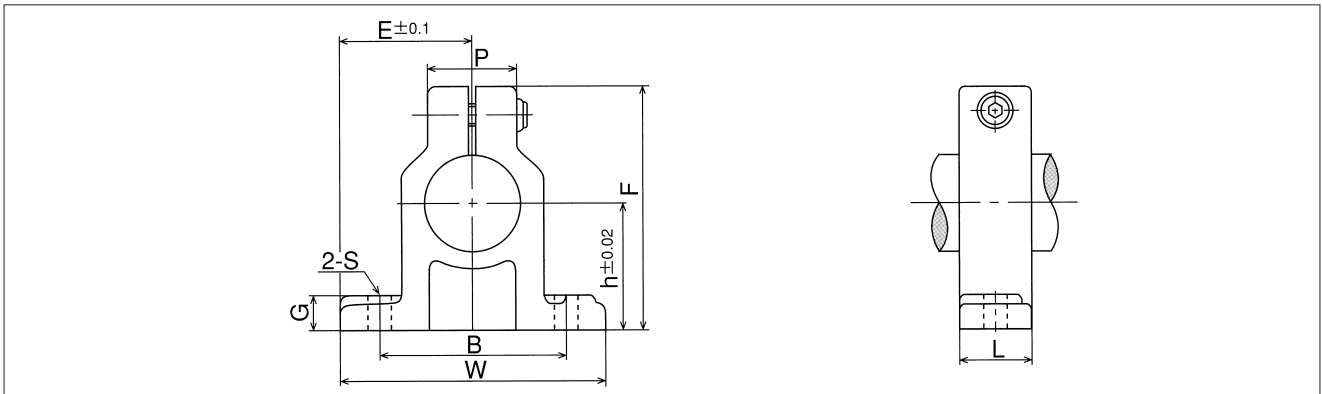
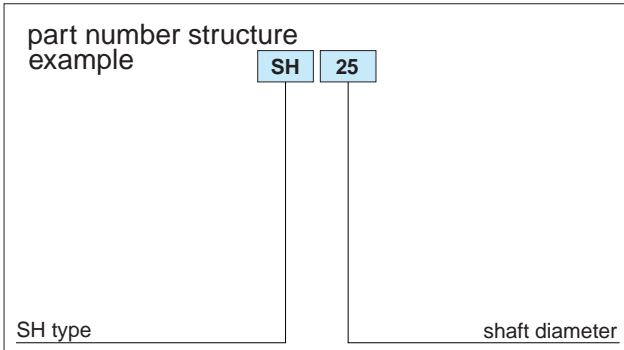

part number	shaft diameter mm	major dimensions									adjusting bolt size	mass g
		h mm	E mm	W mm	L mm	F mm	G mm	P mm	B mm	S (bolt size) mm		
SH10	10	20	22	44	15	35	7	19	32	4.5(M 4)	M 4	80
SH13	13	23	25	50	17	40	8	17	32	7 (M 5)	M 4	120
SH16	16	27	27.5	55	17	45	10	16	38	7 (M 5)	M 4	120
SH20	20	31	32.5	65	20	53	12	22	45	8 (M 6)	M 5	190
SH25	25	35	38	76	24	61	12	24	56	8 (M 6)	M 6	300
SH30	30	42	42.5	85	28	73	15	28	64	10 (M 8)	M 6	490
SH35	35	50	50	100	32	87	15	34	74	12 (M10)	M 8	690
SH40	40	60	60	120	36	104	18	38	90	12 (M10)	M10	1,200
SH50	50	70	70	140	40	122	20	48	100	14 (M12)	M12	1,700
SH60	60	80	82.5	165	45	140	23	58	120	14 (M12)	M12	2,500

SA TYPE

– Shaft Support Rail –

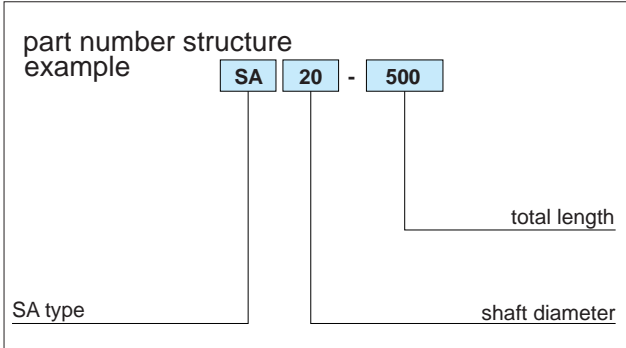
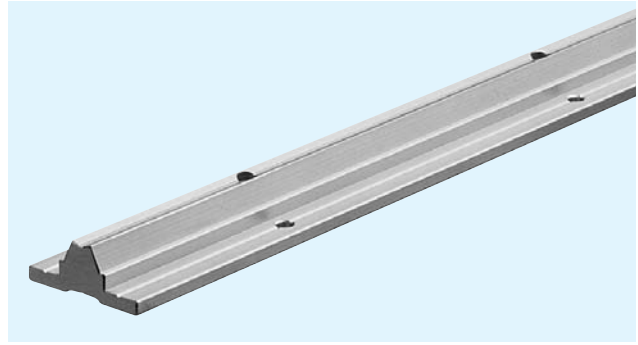

part number	shaft diameter mm	major dimensions														mass g	
		H mm	E mm	W mm	L mm	F mm	T mm	K mm	J mm	h ₁ mm	θ	B mm	N mm	M×P mm	S ₁ mm		S ₂ (bolt size)
SA10-200	10	18	16	32	200	13.5	4	8.9	12.4	4.7	80°	22	50	1×100	4.5	M4	110
SA10-300					300								50	2×100			160
SA10-400					400								50	3×100			220
SA10-500					500								50	4×100			270
SA10-600					600								50	5×100			330
SA13-200					13								21	17			34
SA13-300	300	50	2×100	210													
SA13-400	400	50	3×100	280													
SA13-500	500	50	4×100	350													
SA13-600	600	50	5×100	420													
SA16-200	16	25	20	40		200	17.8	5	11.7	18.5	8	80°			30	25	
SA16-300					300	75							1×150	300			
SA16-400					400	50							2×150	400			
SA16-500					500	25							3×150	500			
SA16-600					600	75							3×150	600			
SA20-200					20	27							22.5	45		200	17.7
SA20-300	300	75	1×150	300													
SA20-400	400	50	2×150	400													
SA20-500	500	25	3×150	510													
SA20-600	600	75	3×150	610													
SA25-200	25	33	27.5	55			200	21	6	12	21.5	8			50°	35	
SA25-300					300	50	1×200						430				
SA25-400					400	100	1×200						580				
SA25-500					500	50	2×200						730				
SA25-600					600	100	2×200						880				

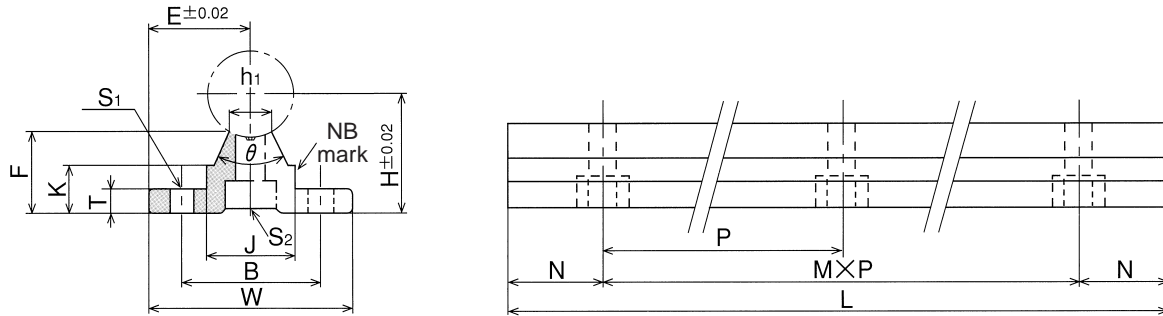

※ Mounting bolts for pre-drilled shaft are included.

part number	shaft diameter mm	major dimensions														mass g	
		H mm	E mm	W mm	L mm	F mm	T mm	K mm	J mm	h ₁ mm	θ	B mm	N mm	M×P mm	S ₁ mm		S ₂ (bolt size)
SA30-200	30	37	30	60	200	22.8	7	13	26.5	10.3	50°	40	25	1×150	6.5	M 8	360
SA30-300					300								50	1×200			550
SA30-400					400								100	1×200			730
SA30-500					500								50	2×200			920
SA30-600					600								100	2×200			1,100
SA35-200	35	43	32.5	65	200	26.5	8	15.5	28	13	50°	45	25	1×150	9	M 8	460
SA35-300					300								50	1×200			700
SA35-400					400								100	1×200			950
SA35-500					500								50	2×200			1,190
SA35-600					600								100	2×200			1,420
SA40-200	40	48	37.5	75	200	29.4	9	17	38	16	50°	55	25	1×150	9	M 8	630
SA40-300					300								75	1×150			960
SA40-400					400								50	1×300			1,290
SA40-500					500								100	1×300			1,610
SA40-600					600								150	1×300			1,950
SA50-200	50	62	47.5	95	200	38.8	11	21	45	20	50°	70	25	1×150	11	M10	1,000
SA50-300					300								75	1×150			1,500
SA50-400					400								50	1×300			2,000
SA50-500					500								100	1×300			2,500
SA50-600					600								150	1×300			3,000

CE TYPE

– Non-Clearance Adjustable Type –

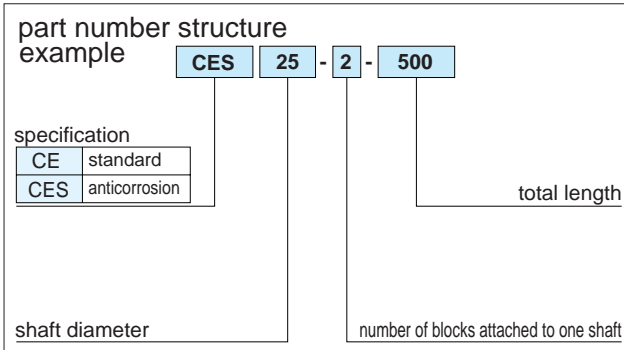
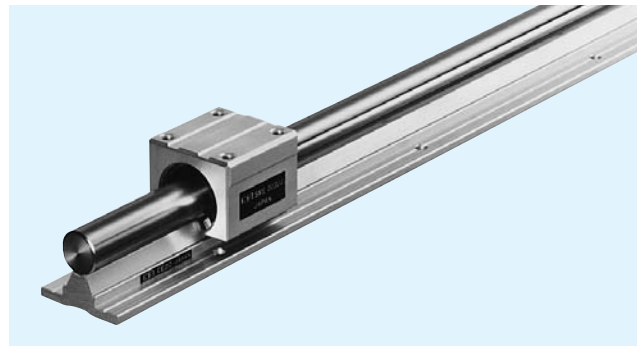

part number		shaft diameter mm	assembly dimension											major dimensions					
standard	anticorrosion		H	h	W ₁	W ₂	L ₁	B ₁	C	T ₁	ℓ	S ₁	F	W ₃	B ₂	T ₂	P	S ₂	
CE16	CES16	16	45	25	2.5	45	45	32	30	9	12	M5	33	40	30	5	150	5.5	
CE20	CES20	20	50	27	1.5	48	50	35	35	11	12	M6	39	45	30	5	150	5.5	
CE25	CES25	25	60	33	2.5	60	65	40	40	14	12	M6	47	55	35	6	200	6.5	
CE30	CES30	30	70	37	5	70	70	50	50	15	18	M8	56	60	40	7	200	6.5	

* Longer length are available. Please contact NB in case of the length exceeds 2,000mm.

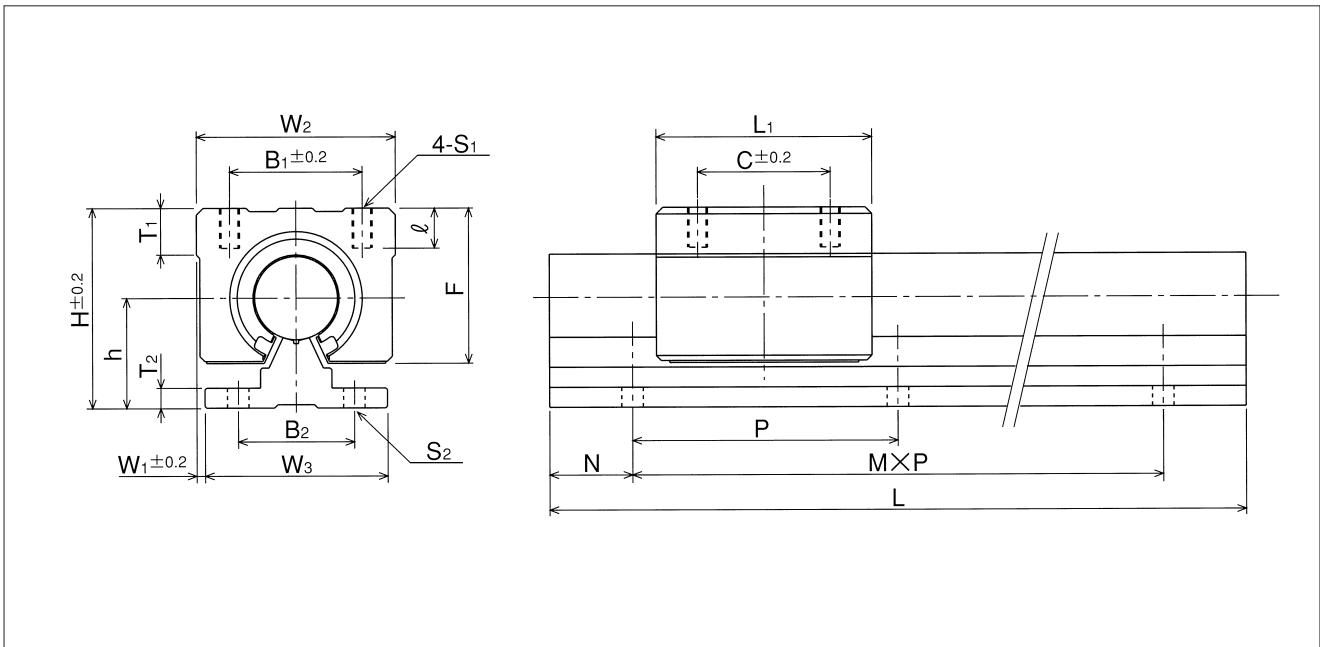

rail dimensions				basic load rating		mass		size
				dynamic C N	static Co N	block g	rail kg/m	
*L(M,N) mm								
300(1,75)	500(3,25)	800(5,25)	1,000(6,50)	774	1,180	150	2.58	16
1,500(9,75)	1,800(11,75)	2,000(13,25)						
300(1,75)	500(3,25)	800(5,25)	1,000(6,50)	882	1,370	200	3.49	20
1,500(9,75)	1,800(11,75)	2,000(13,25)						
300(1,50)	500(2,50)	800(3,100)	1,000(4,100)	980	1,570	450	5.31	25
1,500(7,50)	1,800(8,100)	2,000(9,100)						
300(1,50)	500(2,50)	800(3,100)	1,000(4,100)	1,570	2,740	630	7.39	30
1,500(7,50)	1,800(8,100)	2,000(9,100)						

1N \approx 0.102kgf

CD TYPE

– Clearance Adjustable Type –

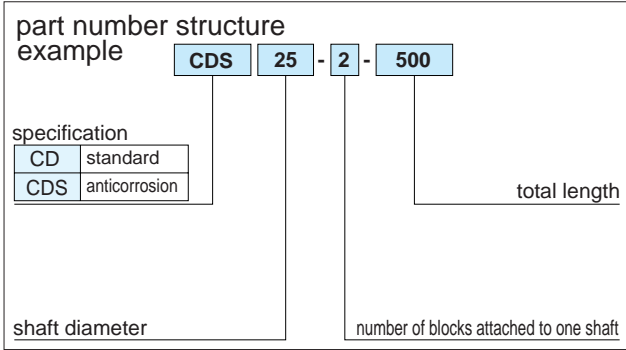
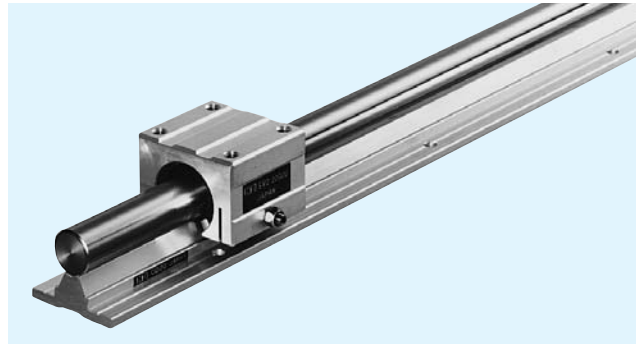

part number		shaft diameter mm	assembly dimensions											major dimensions					
standard	anticorrosion		H	h	W ₁	W ₂	L ₁	B ₁	C	T ₁	ℓ	S ₁	G	F	W ₃	B ₂	T ₂	P	S ₂
CD16	CDS16	16	45	25	5	50	45	36	30	9	12	M5	6	33	40	30	5	150	5.5
CD20	CDS20	20	50	27	4.5	54	50	40	35	11	12	M6	7	39	45	30	5	150	5.5
CD25	CDS25	25	60	33	10.5	76	65	54	40	14	12	M6	7	47	55	35	6	200	6.5
CD30	CDS30	30	70	37	9	78	70	58	50	15	18	M8	7	56	60	40	7	200	6.5

* Longer length are available. Please contact NB in case of the length exceeds 2,000mm.

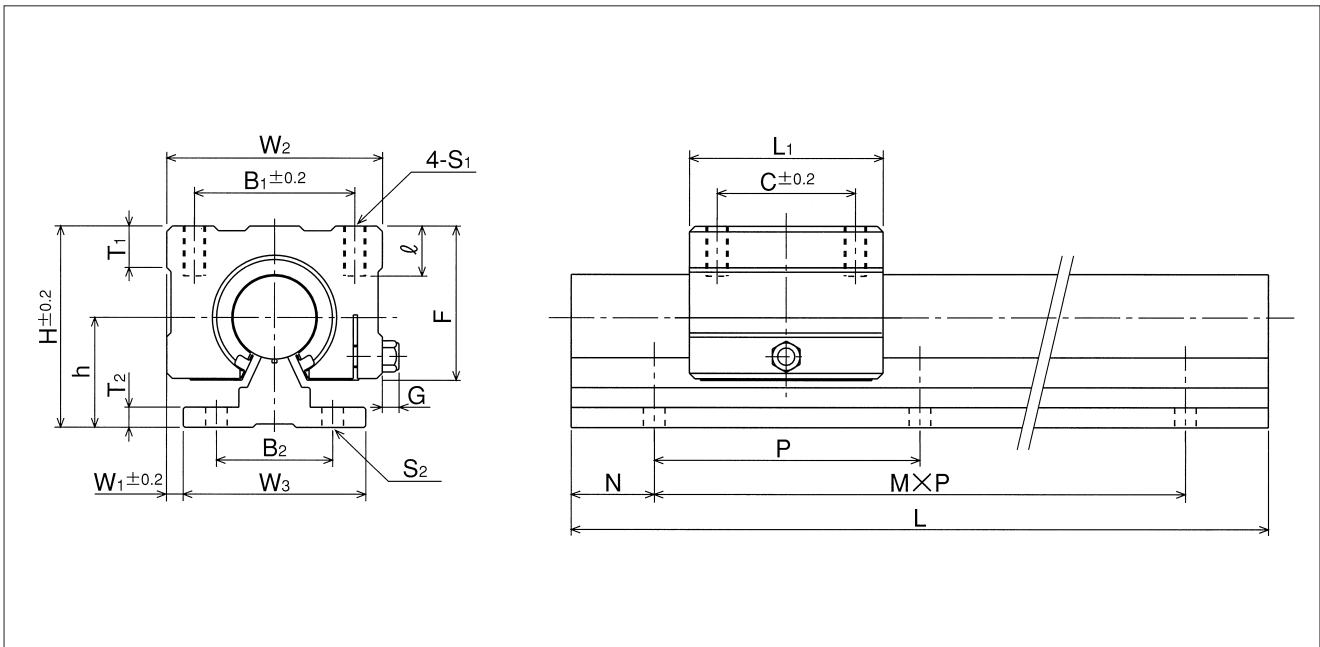

rail dimensions				basic load rating		mass		size
				dynamic C N	static Co N	block g	rail kg/m	
*L(M,N) mm								
300(1,75)	500(3,25)	800(5,25)	1,000(6,50)	774	1,180	170	2.58	16
1,500(9,75)	1,800(11,75)	2,000(13,25)						
300(1,75)	500(3,25)	800(5,25)	1,000(6,50)	882	1,370	240	3.49	20
1,500(9,75)	1,800(11,75)	2,000(13,25)						
300(1,50)	500(2,50)	800(3,100)	1,000(4,100)	980	1,570	580	5.31	25
1,500(7,50)	1,800(8,100)	2,000(9,100)						
300(1,50)	500(2,50)	800(3,100)	1,000(4,100)	1,570	2,740	720	7.39	30
1,500(7,50)	1,800(8,100)	2,000(9,100)						

1N \approx 0.102kgf

SWA TYPE

– Block Type –

(Inch Series)

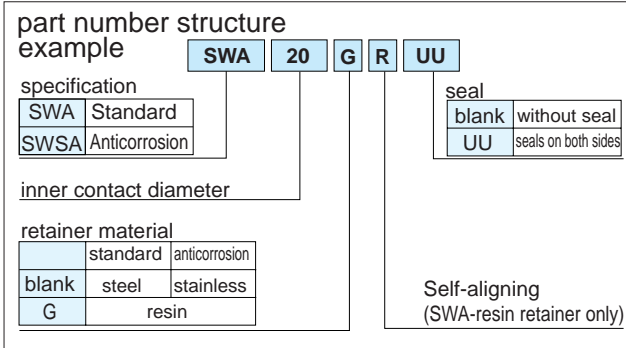
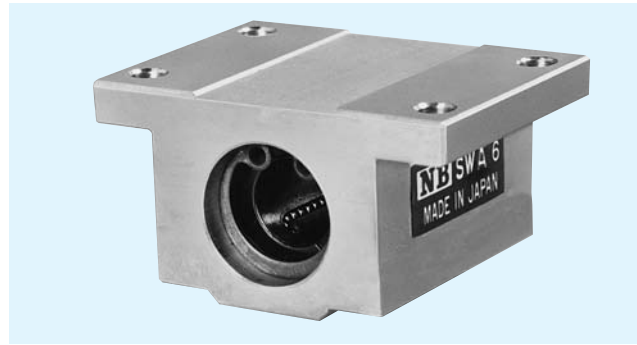

part number	major dimensions							
	inner contact diameter		outer dimensions					
	inch/mm	tolerance inch/ μ m	h $\pm .001/\pm 0.02$ inch/mm	E $\pm .001/\pm 0.02$ inch/mm	W inch/mm	L inch/mm	F inch/mm	T inch/mm
SWA 4GUU	.2500 6.350	0 - .00040	.4370 11.100	.8125 20.638	1.625 41.28	1.188 30.16	.813 20.64	.188 4.76
SWA 6GUU	.3750 9.525		.5000 12.700	.8750 22.225	1.750 44.45	1.313 33.34	.938 23.82	.188 4.76
SWA 8GUU	.5000 12.700		.6870 17.450	1.0000 25.400	2.000 50.80	1.688 42.86	1.250 31.75	.250 6.35
SWA 10GUU	.6250 15.875	0 -9	.8750 22.225	1.2500 31.750	2.500 63.50	1.938 49.21	1.625 41.28	.281 7.14
SWA 12GUU	.7500 19.050	0 - .00040	.9370 23.800	1.3750 34.925	2.750 69.85	2.063 52.39	1.750 44.45	.313 7.94
SWA 16GUU	1.0000 25.400	0 -10	1.1870 30.150	1.6250 41.275	3.250 82.55	2.813 71.44	2.188 55.56	.375 9.53
SWA 20GUU	1.2500 31.750	0 - .00050	1.5000 38.100	2.0000 50.800	4.000 101.60	3.625 92.08	2.813 71.44	.438 11.11
SWA 24GUU	1.5000 38.100	0 - .00050	1.7500 44.450	2.3750 60.325	4.750 120.65	4.000 101.60	3.250 82.55	.500 12.70
SWA 32GUU	2.0000 50.800	0 -12	2.1250 53.975	3.0000 76.200	6.000 152.40	5.000 127.00	4.063 103.19	.625 15.88

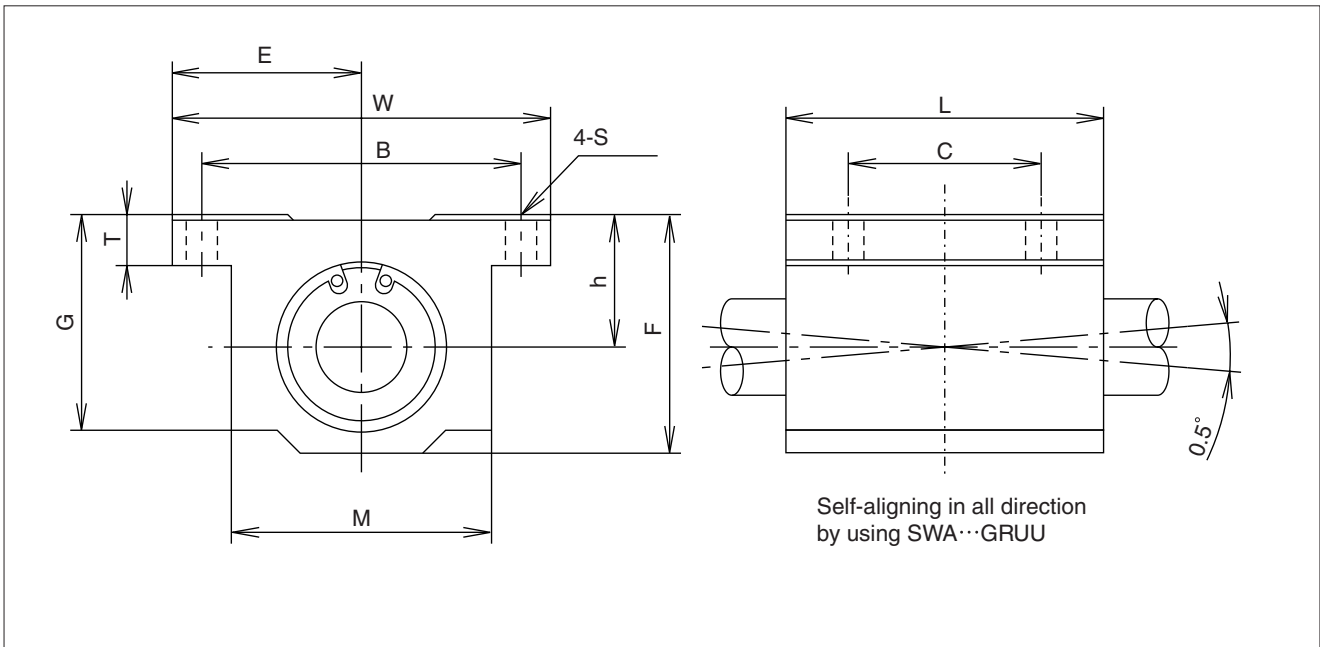

G	M	mounting dimension			basic load rating		mass	part number
		B	C	S	dynamic C	static Co		
inch/mm	inch/mm	$\pm 0.01/\pm 0.2$ inch/mm	$\pm 0.01/\pm 0.2$ inch/mm	inch/mm	N	N	g	
.750 19.05	1.000 25.40	1.312 33.33	.750 19.05	.156 4.0	206	265	45	SWA 4GUU
.875 22.23	1.125 28.58	1.437 36.50	.875 22.23	.156 4.0	225	314	62	SWA 6GUU
1.125 28.58	1.375 34.93	1.688 42.88	1.000 25.40	.156 4.0	510	784	130	SWA 8GUU
1.437 36.50	1.750 44.45	2.125 53.98	1.125 28.58	.188 4.8	774	1,180	240	SWA 10GUU
1.563 39.69	1.875 47.63	2.375 60.33	1.250 31.75	.188 4.8	862	1,370	290	SWA 12GUU
1.938 49.21	2.375 60.33	2.875 73.03	1.750 44.45	.219 5.6	980	1,570	615	SWA 16GUU
2.500 63.50	3.000 76.20	3.500 88.90	2.000 50.80	.219 5.6	1,570	2,740	1,300	SWA 20GUU
2.875 73.03	3.500 88.90	4.125 104.78	2.500 63.50	.281 7.2	2,160	4,020	1,900	SWA 24GUU
3.625 92.08	4.500 114.30	5.250 133.35	3.250 82.55	.406 10.5	3,820	7,940	3,600	SWA 32GUU

SI UNIT 1N \approx 0.225lbs
1kg \approx 2.205lbs

SWJ TYPE

– Clearance Adjustable Block Type –
(Inch Series)

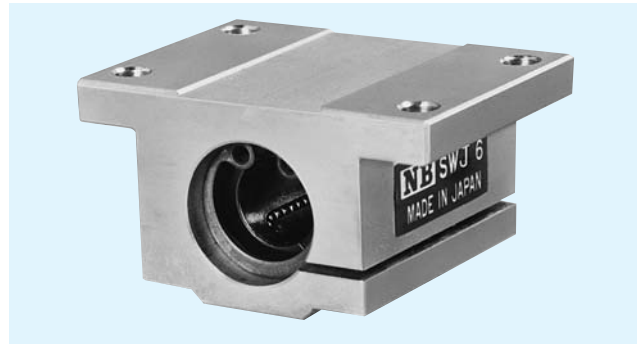

part number structure		example		SWJ		20		G		R		UU			
specification		SWJ		Standard		SWSJ		Anticorrosion		seal		blank		without seal	
inner contact diameter		blank		steel		stainless		G		resin		UU		seals on both sides	
retainer material		blank		steel		stainless		G		resin		Self-aligning		(SWA-resin retainer only)	

part number	major dimensions						
	inner contact diameter	outer dimensions					
		h	E	W	L	F	T
inch/mm	$\pm.001/\pm 0.02$ inch/mm	$\pm.001/\pm 0.02$ inch/mm	inch/mm	inch/mm	inch/mm	inch/mm	
SWJ 8GUU	.5000 12.700	.6870 17.450	1.0000 25.400	2.000 50.80	1.688 42.86	1.250 31.75	.250 6.35
SWJ 10GUU	.6250 15.875	.8750 22.225	1.2500 31.750	2.500 63.50	1.938 49.21	1.625 41.28	.281 7.14
SWJ 12GUU	.7500 19.050	.9370 23.800	1.3750 34.925	2.750 69.85	2.063 52.39	1.750 44.45	.313 7.94
SWJ 16GUU	1.0000 25.400	1.1870 30.150	1.6250 41.275	3.250 82.55	2.813 71.44	2.188 55.56	.375 9.53
SWJ 20GUU	1.2500 31.750	1.5000 38.100	2.0000 50.800	4.000 101.60	3.625 92.08	2.813 71.44	.438 11.11
SWJ 24GUU	1.5000 38.100	1.7500 44.450	2.3750 60.325	4.750 120.65	4.000 101.60	3.250 82.55	.500 12.70
SWJ 32GUU	2.0000 50.800	2.1250 53.975	3.0000 76.200	6.000 152.40	5.000 127.00	4.063 103.19	.625 15.88

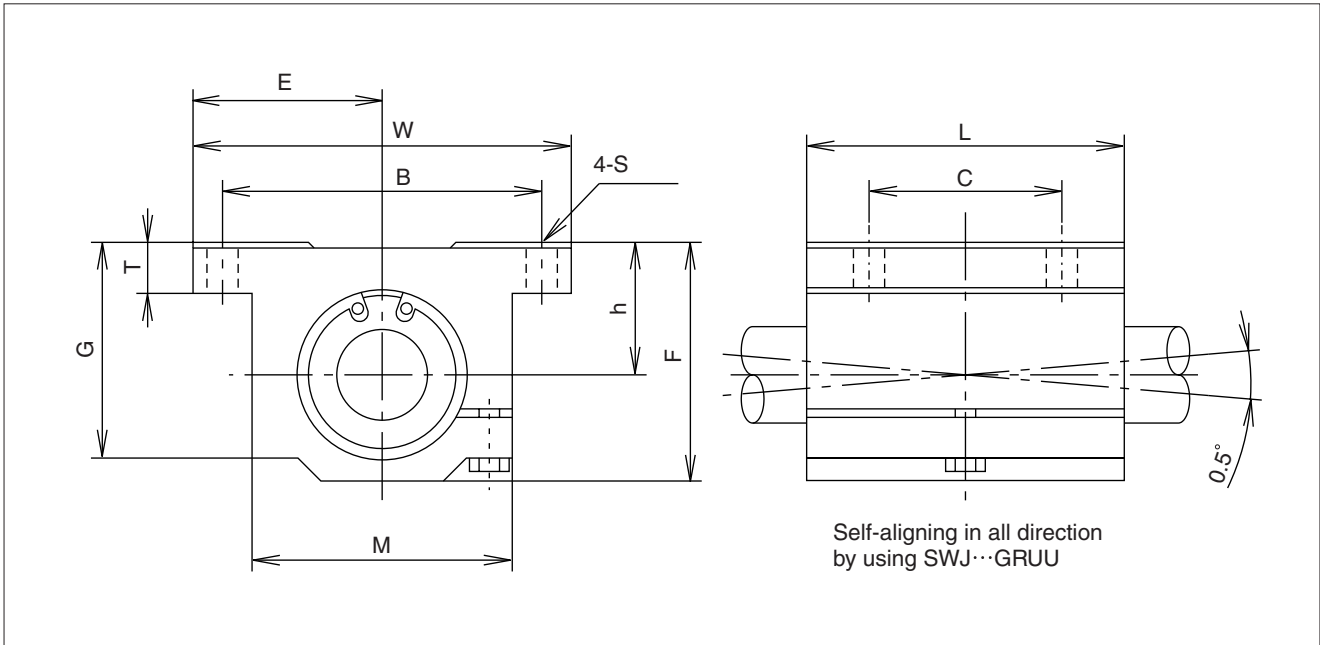

					basic load rating		mass	part number
G	M	mounting dimensions			dynamic	static		
inch/mm	inch/mm	$\pm .01/\pm 0.2$ inch/mm	$\pm .01/\pm 0.2$ inch/mm	S inch/mm	C N	Co N	g	
1.125 28.58	1.375 34.93	1.688 42.88	1.000 25.40	.156 4.0	510	784	130	SWJ 8GUU
1.437 36.50	1.750 44.45	2.125 53.98	1.125 28.58	.188 4.8	774	1,180	240	SWJ 10GUU
1.563 39.69	1.875 47.63	2.375 60.33	1.250 31.75	.188 4.8	862	1,370	290	SWJ 12GUU
1.938 49.21	2.375 60.33	2.875 73.03	1.750 44.45	.219 5.6	980	1,570	615	SWJ 16GUU
2.500 63.50	3.000 76.20	3.500 88.90	2.000 50.80	.219 5.6	1,570	2,740	1,300	SWJ 20GUU
2.875 73.03	3.500 88.90	4.125 104.78	2.500 63.50	.281 7.2	2,160	4,020	1,900	SWJ 24GUU
3.625 92.08	4.500 114.30	5.250 133.35	3.250 82.55	.406 10.5	3,820	7,940	3,600	SWJ 32GUU

SI UNIT 1N \approx 0.225lbs

1kg \approx 2.205lbs

SWD TYPE

– Open Block Type –

(Inch Series)

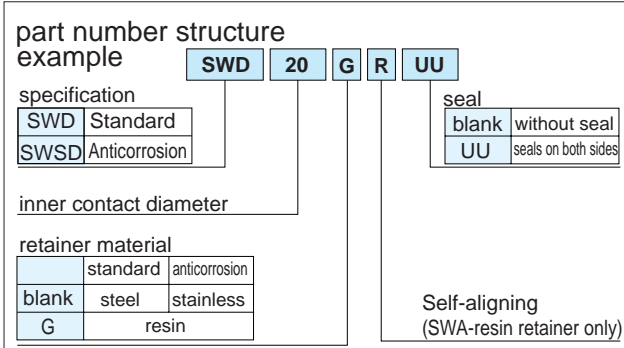
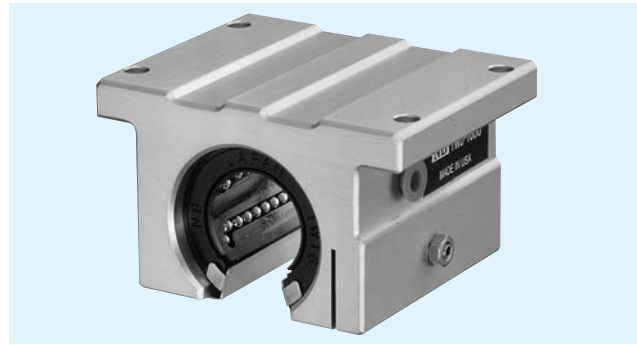

part number	major dimensions							
	inner contact diameter	outer dimensions						
		h	E	W	L	F	T	G
inch/mm	$\pm 0.001/\pm 0.02$ inch/mm	$\pm 0.001/\pm 0.02$ inch/mm	inch/mm	inch/mm	inch/mm	inch/mm	inch/mm	
SWD 8GUU	.5000 12.700	.6870 17.450	1.0000 25.400	2.000 50.80	1.500 38.10	1.100 27.94	.250 6.35	.688 17.5
SWD 10GUU	.6250 15.875	.8750 22.225	1.2500 31.750	2.500 63.50	1.750 44.45	1.375 34.93	.281 7.14	.875 22.23
SWD 12GUU	.7500 19.050	.9370 23.800	1.3750 34.950	2.750 69.85	1.875 47.63	1.535 39.00	.315 8.00	.937 23.80
SWD 16GUU	1.0000 25.400	1.1870 30.150	1.6250 41.300	3.250 82.55	2.625 66.68	1.975 50.17	.375 9.53	1.188 30.18
SWD 20GUU	1.2500 31.750	1.5000 38.100	2.0000 50.800	4.000 101.60	3.375 85.73	2.485 63.12	.437 11.10	1.500 38.10
SWD 24GUU	1.5000 38.100	1.7500 44.450	2.3750 60.325	4.750 120.65	3.750 95.25	2.910 73.90	.500 12.70	1.750 44.45
SWD 32GUU	2.0000 50.800	2.1250 53.975	3.0000 76.200	6.000 152.4	4.750 120.65	3.660 92.90	.625 15.88	2.250 57.15

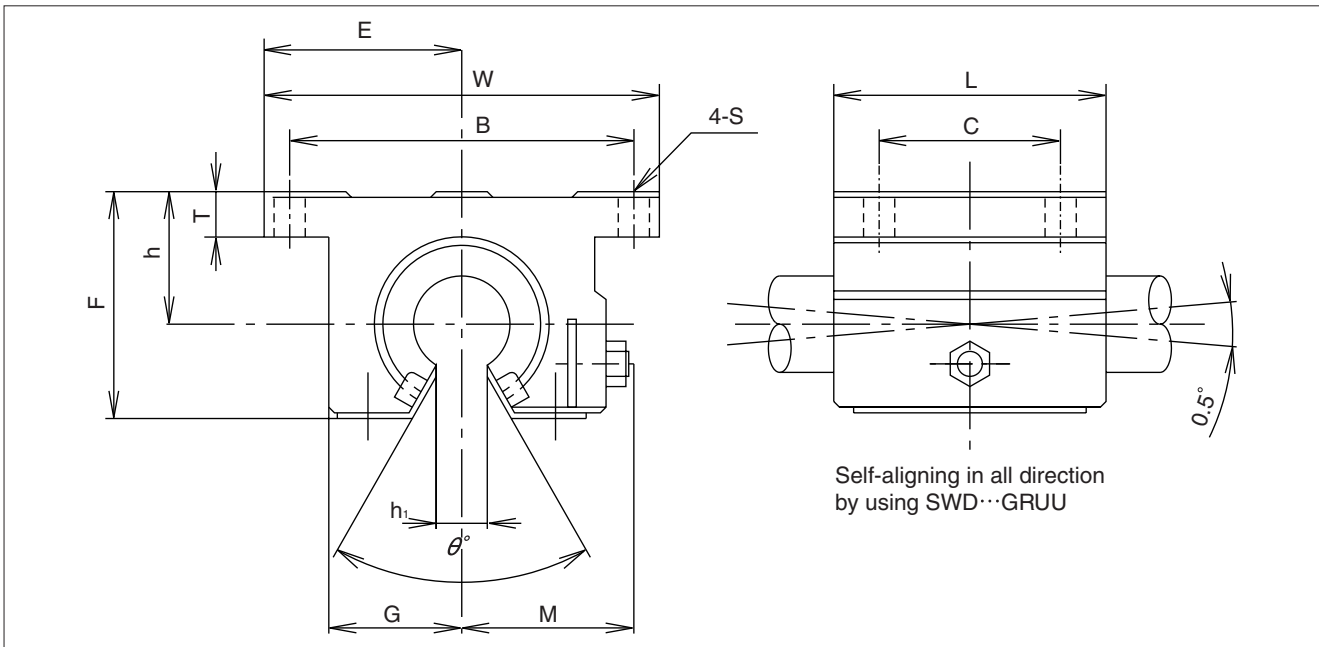

			mounting dimensions			basic load rating		mass	Part number
M	h_1	θ	B	C	S	dynamic C	static Co	g	
inch/mm	inch/mm		$\pm.01/\pm0.2$ inch/mm	$\pm.01/\pm0.2$ inch/mm	inch/mm	N	N		
.98 24.89	.3425 8.70	80°	1.688 42.88	1.000 25.40	.156 4.0	510	784	98	SWD 8GUU
1.15 29.21	.375 9.53	80°	2.125 53.98	1.125 28.58	.188 4.8	774	1,180	185	SWD 10GUU
1.23 31.24	.4375 11.11	60°	2.375 60.33	1.250 31.75	.188 4.8	862	1,370	235	SWD 12GUU
1.48 37.59	.5625 14.29	50°	2.875 73.03	1.750 44.45	.218 5.6	980	1,570	530	SWD 16GUU
1.88 47.75	.625 15.88	50°	3.500 88.90	2.000 50.80	.218 5.6	1,570	2,740	1,080	SWD 20GUU
2.12 53.85	.750 19.05	50°	4.125 104.78	2.500 63.50	.281 7.4	2,160	4,020	1,620	SWD 24GUU
2.70 68.58	1.00 25.40	50°	5.250 133.35	3.250 82.55	.406 10.5	3,820	7,940	3,100	SWD 32GUU

SI UNIT 1N \approx 0.225lbs

1kg \approx 2.205lbs

WH-A TYPE

— Shaft End Supporter —
(Inch Series)

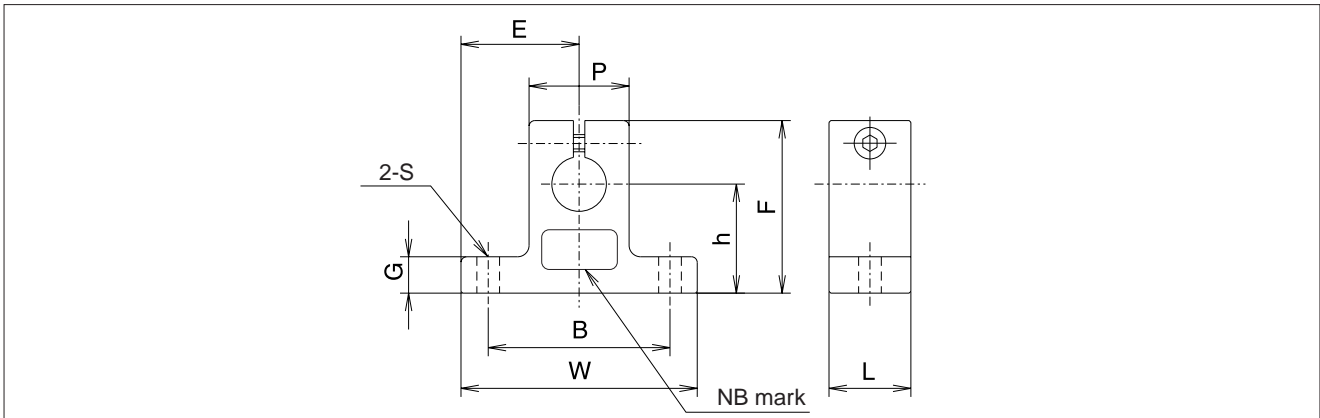
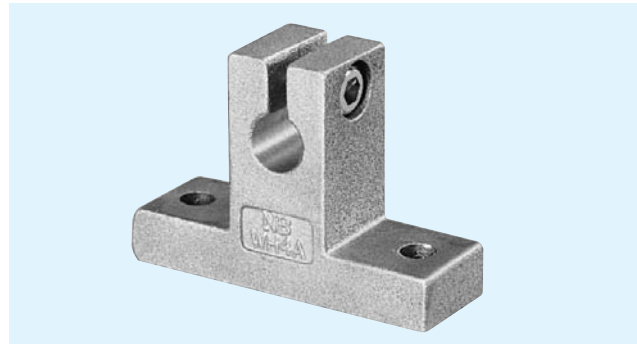

part number	shaft diameter inch/mm	major dimensions inch/mm										mass g
		h	E	W	L	F	G	P	B	S	BOLT	
		$\pm .001$ ± 0.02	$\pm .005$ ± 0.1						$\pm .01$ ± 0.2			
WH 4A	.2500 6.350	.6875 17.463	.7500 19.050	1.500 38.10	.500 12.70	1.063 27.00	.250 6.35	.500 12.70	1.125 28.58	.156 4.0	# 6	15
WH 6A	.3750 9.525	.7500 19.050	.8125 20.637	1.625 41.28	.563 14.30	1.187 30.16	.250 6.35	.688 17.46	1.250 31.75	.156 4.0	# 6	21
WH 8A	.5000 12.700	1.0000 25.400	1.0000 25.400	2.000 50.80	.625 15.88	1.625 41.28	.250 6.35	.875 22.23	1.500 38.10	.188 4.8	# 8	35
WH 10A	.6250 15.875	1.0000 25.400	1.2500 31.750	2.500 63.50	.688 17.46	1.750 44.45	.313 7.94	1.000 25.40	1.875 47.63	.218 5.6	#10	52
WH 12A	.7500 19.050	1.2500 31.750	1.2500 31.750	2.500 63.50	.750 19.05	2.063 52.40	.313 7.94	1.250 31.75	2.000 50.80	.218 5.6	#10	74
WH 16A	1.0000 25.400	1.5000 38.100	1.5315 38.900	3.063 77.80	1.000 25.40	2.500 63.50	.375 9.53	1.500 38.10	2.500 63.50	.281 7.2	1/4	136
WH 20A	1.2500 31.750	1.7500 44.450	1.8750 47.625	3.750 95.25	1.125 28.58	3.000 76.20	.438 11.14	2.000 50.80	3.000 76.20	.346 8.8	5/16	254
WH 24A	1.5000 38.100	2.0000 50.800	2.1875 55.550	4.375 111.13	1.250 31.75	3.437 87.30	.500 12.70	2.250 57.15	3.500 88.90	.346 8.8	5/16	340
WH 32A	2.0000 50.800	2.5000 63.500	2.7500 69.850	5.500 139.70	1.500 38.10	4.375 111.13	.625 15.88	3.000 76.20	4.500 114.30	.406 10.5	3/8	670

1 kg \approx 2.205lbs

WA TYPE

— Shaft Support Rail —

(Inch Series)

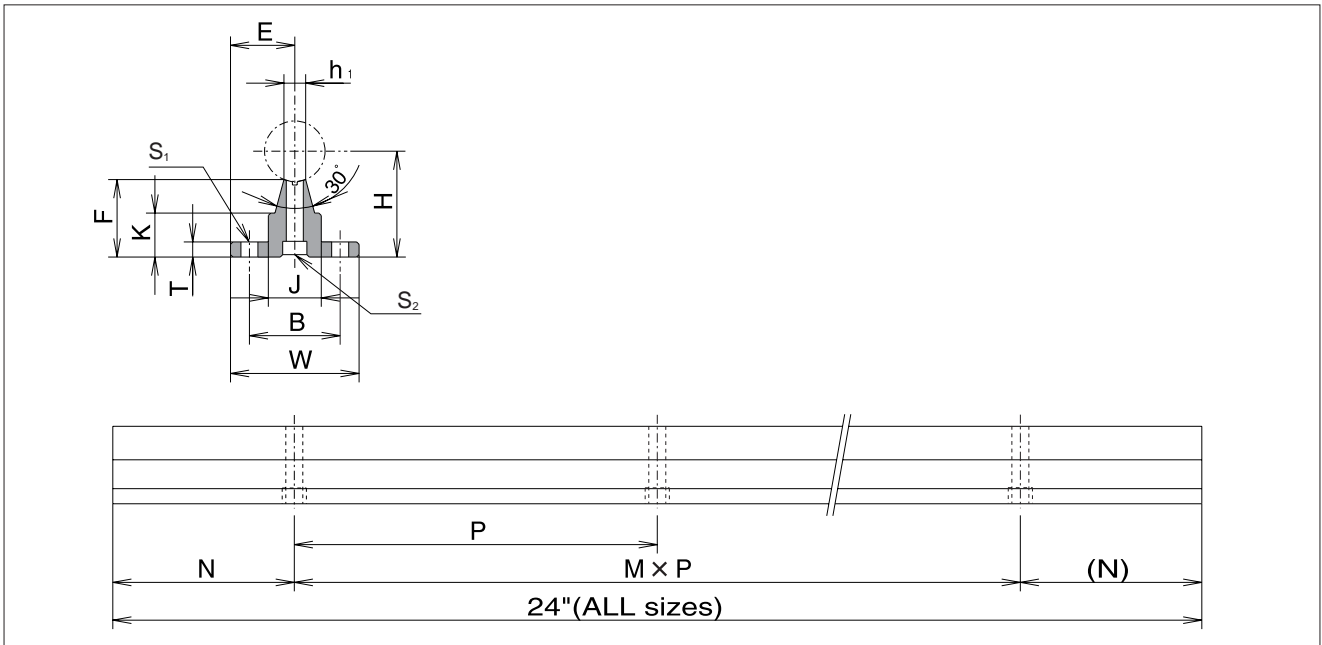
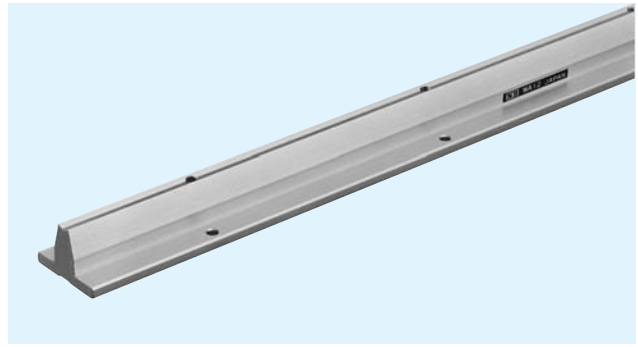

part number	shaft diameter	major dimensions								mounting dimensions						mass g	
		H	E	W	F	T	K	J	h ₁	B	N	M × P	S ₁		S ₂		
		±.001	±.005							±.01			hole	bolt#	hole		bolt#
		±0.02	±0.1							±0.2			inch/mm	inch/mm	inch/mm		inch/mm
	inch/mm	inch/mm	inch/mm	inch/mm	inch/mm	inch/mm	inch/mm	inch/mm	inch/mm	inch/mm	inch/mm	inch/mm	inch/mm	inch/mm	inch/mm	inch/mm	
WA 8-24PD	.5000	1.125	.7500	1.500	.903	.188	.466	.500	.255	1.000	2	5 × 4	.169	# 6	.169	# 6	600
	12.700	28.575	19.050	38.10	22.94	4.78	11.84	12.70	6.48	25.40	50.8	5 × 101.6	4.3	# 6	4.3	# 6	
WA10-24PD	.6250	1.125	.8125	1.625	.841	.250	.423	.500	.276	1.125	2	5 × 4	.193	# 8	.193	# 8	680
	15.875	28.575	20.638	41.28	21.36	6.35	10.74	12.70	7.01	28.58	50.8	5 × 101.6	4.9	# 8	4.9	# 8	
WA12-24PD	.7500	1.500	.8750	1.750	1.158	.250	.592	.625	.322	1.250	3	3 × 6	.221	#10	.221	#10	910
	19.050	38.100	22.225	44.45	29.41	6.35	15.04	15.88	8.18	31.75	76.2	3 × 152.4	5.6	#10	5.6	#10	
WA16-24PD	1.0000	1.750	1.0625	2.125	1.280	.250	.727	.875	.359	1.500	3	3 × 6	.281	1/4	.281	1/4	1290
	25.400	44.450	26.988	53.98	32.51	6.35	18.47	22.23	9.12	38.10	76.2	3 × 152.4	7.1	1/4	7.1	1/4	
WA20-24PD	1.2500	2.125	1.2500	2.500	1.537	.313	.799	1.100	.437	1.875	3	3 × 6	.343	5/16	.343	5/16	1810
	31.750	53.975	31.750	63.50	39.04	7.95	20.29	27.94	11.10	47.63	76.2	3 × 152.4	8.7	5/16	8.7	5/16	
WA24-24PD	1.5000	2.500	1.5000	3.000	1.798	.375	.922	1.375	.558	2.250	4	2 × 8	.343	5/16	.406	3/8	2610
	38.100	63.500	38.100	76.20	45.67	9.53	23.42	34.93	14.17	57.15	101.6	2 × 203.2	8.7	5/16	10.3	3/8	
WA32-24PD	2.0000	3.250	1.8750	3.750	2.322	.500	1.450	1.500	.800	2.750	4	2 × 8	.406	3/8	.531	1/2	4380
	50.800	82.550	47.625	95.25	58.98	12.70	36.83	38.10	20.32	69.85	101.6	2 × 203.2	10.3	3/8	13.5	1/2	

All sizes are also available without pre-drilled mounting holes. Specify Part Number as WA ##-## when ordering. Complete shaft-rail assemblies are also available as well as custom drilling and lengths. Please send drawing for quotation on custom configurations. 1kg ≅ 2.205lbs