

LINEAR MOTION SYSTEMS







Simplicity® Self-lubricated Bearings, Guides, Systems & Slides









800.962.8979 www.pacific-bearing.com

SMOOTH & QUIET LINEAR MOTION™





SIMPLICITY® SELF-LUBRICATING BEARINGS - INCH SERIES

	FL & FLN 10-11 Open & Closed Linear Bearings		SFP & DFP 14 Flange Mounts
	P & PN 12 Open & Closed Pillow Blocks		SDS & DDS 15 Flange Mount Die Sets
	PW & PWN 13 Open & Closed Twin Pillow Blocks		PAC 16 Flange Mount Die Sets
			Notes Page 17

SIMPLICITY® SELF-LUBRICATING BEARINGS - ISO METRIC

	FM & FMN 18-19 Open & Closed Linear Bearings		SFPM 25 Flange Bearings
	PM & PMN 20-21 Closed & Open Pillow Blocks		DFPM 26 Flange Bearings
	FMT & FG 22-23 Compact Thin Wall Bearings		CFPM 27 Flange Bearings
	PACM 24 Die Set Bushings		

SIMPLICITY® SELF-LUBRICATING BEARINGS - JIS METRIC

	FJH, FJ & FJN 28-29 Open & Closed Linear Bearings		DFPJ 31 Flange Bearings
	SFPJ 30 Flange Bearings		CFPJ 32 Flange Bearings

SIMPLICITY® SQUARE BEARINGS











	Technical Information 33-34		Square Shafting & Accessories 37
	1.0" Specifications 35		
	1.5" Specifications 36		

The data and specifications in this publication have been carefully compiled and are believed to be accurate and correct. However, it is the responsibility of the user to determine and ensure the suitability of Pacific Bearing® products for a specific application. Pacific Bearing's only obligation will be to repair or replace without charge, any defective components if returned promptly. No liability is assumed beyond such replacement. *Consult www.pacific-bearing.com for the latest technical updates.





SIMPLICITY® SELF-LUBRICATING BEARINGS - TECHNICAL INFORMATION

What Makes Simplicity® the Right Choice.....	38	Vacuums/Outgassing/Clean Rooms.....	50
What Gives Simplicity these Advantages.....	39	Classes of Plane Bearings.....	51
Bearing Liner Material.....	40	Rating a Plane Bearing.....	51
Running Clearance.....	40	Simplicity Maximum Perimeter.....	51
Bearing Shell.....	40-41	Formulas for Ratings.....	51
Self-Alignment Feature.....	41	PV Equivalents.....	51
Pillow Blocks.....	42	Wear Rate VS. Life Expectancy.....	52
Pillow Blocks - Additional Features.....	42-43	Coefficient of Friction.....	53
Load Capacity of Liner.....	44	Load Capacity (Pressure).....	54
Speed Characteristics.....	44	Linear Surface Speeds (Velocity).....	54
Performance Ratings (for Linear Motion).....	44	Factors that Contribute to Wear Life.....	54
Wear Rate/Life Expectancy.....	45	Types and Effects of Lubrication.....	54
Factors Affecting Wear Rate/Life.....	45	Using Oils with Simplicity.....	55
Transfer Process of Liner to Shaft.....	46	Grease Products.....	55
Lubrication.....	46	Proper use of Greases.....	55
Temperature.....	47	Effects of Lubrication.....	55
Thermal Expansion.....	47	Application Information.....	56
Rotary Applications.....	47	Shaft Deflection.....	57
Open Bearings Orientation.....	48	Total Deflection.....	57
Cantilevered Loads.....	48	Displacement Angle.....	57
Severe Misalignment Solutions.....	49	Installing Simplicity Bearings.....	58-61
Chemical Resistance.....	50	Chemical Reaction Chart.....	62
Submerged Applications.....	50		

SIMPLICITY® LINEAR SHAFTING - INCH SERIES









 RC60 Steel Shafting.....	63	 Feather Shafting.....	66
 440 Stainless Steel Shafting.....	64		Ceramic Coated Aluminum Solid and Pre-Drilled & Tapped Shafting
 Aluminum Pre-Drilled Support Rails.....	64	 Feather Rails.....	67
 Aluminum End Support Blocks.....	64		Ceramic Coated Aluminum Rail Assembly
 Aluminum Non-Drilled Support Rails.....	65		
 Steel Shaft Rail Assembly.....	65		

SIMPLICITY® LINEAR SHAFTING - ISO METRIC







 RC60 Steel Shafting.....	68	 Feather Shafting.....	69
 440 Stainless Steel Shafting.....	69		Ceramic Coated Aluminum Solid and Pre-Drilled & Tapped Shafting

The data and specifications in this publication have been carefully compiled and are believed to be accurate and correct. However, it is the responsibility of the user to determine and ensure the suitability of Pacific Bearing® products for a specific application. Pacific Bearing's only obligation will be to repair or replace without charge, any defective components if returned promptly. No liability is assumed beyond such replacement. *Consult www.pacific-bearing.com for the latest technical updates.









SIMPLICITY® BALL BEARINGS - INCH SERIES

 IP Series 70-71 Linear Ball Bearings	 IPK-W Series 80-81 Square Flange Mount Double Wide
 IP-W Series 72-73 Double Wide Linear Ball Bearings	 IPFC Series 82-83 Round Flange Center Mount
 IPF Series 74-75 Round Flange Mount	 IPKC Series 84-85 Square Flange Center Mount
 IPF-W Series 76-77 Round Flange Mount Double Wide	 IPP & IPPN 86 Closed & Open Pillow Blocks
 IPK Series 78-79 Square Flange Mount	 IPPW & IPPWN 87 Closed & Open Twin Pillow Blocks

SIMPLICITY® BALL BEARINGS - ISO METRIC

 EP Series 88-89 Linear Ball Bearings	 EPK-W Series 98-99 Square Flange Mount Double Wide
 EP-W Series 90-91 Double Wide Linear Ball Bearings	 EPFC Series 100-101 Round Flange Center Mount
 EPF Series 92-93 Round Flange Mount	 EPKC Series 102-103 Square Flange Center Mount
 EPF-W Series 94-95 Round Flange Mount Double Wide	 EPPM & EPPMN 104 Closed & Open Pillow Blocks
 EPK Series 96-97 Square Flange Mount	 KHP 105 Compact Thin Wall Bearings

SIMPLICITY® BALL BEARINGS - JIS METRIC





 JP Series 106-107 Linear Ball Bearings	 JPK Series 114-115 Square Flange Mount
 JP-W Series 108-109 Double Wide Linear Ball Bearings	 JPK-W Series 116-117 Square Flange Mount Double Wide
 JPF Series 110-111 Round Flange Mount	 JPFC Series 118-119 Round Flange Center Mount
 JPF-W Series 112-113 Round Flange Mount Double Wide	 JPKC Series 120-121 Square Flange Center Mount

SIMPLICITY® BALL BEARINGS - TECHNICAL INFORMATION

Product Overview 122	Rating Life 125-126
Load Rating and Life Expectancy 123	Sample Calculations 125
Relation Between Ball Circuits and Load Rating 123	Frictional Resistance 127
Clearance & Fit 124	Ambient Working Temperature 127
Shaft & Housing 124	Lubrication and Dust Prevention 127
Mounting 124	

The data and specifications in this publication have been carefully compiled and are believed to be accurate and correct. However, it is the responsibility of the user to determine and ensure the suitability of Pacific Bearing® products for a specific application. Pacific Bearing's only obligation will be to repair or replace without charge, any defective components if returned promptly. No liability is assumed beyond such replacement. *Consult www.pacific-bearing.com for the latest technical updates.

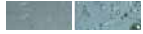
SIMPLICITY® PLANE BEARINGS - POLYMER SERIES

	Product Overview	128-130
	Technical Data Standard Compounds	131
	Chemical Resistance	132
	Compounds A & E	133
	Compounds B & C	134
	Compounds D & F	135
	Compound G	136

	E	137-141
	Flanged E	142-145
	Thrust Washers	146
	With Seals E	147
	Ultra High Temperature Resistant - A	148-150
	Design Notes	151
	From Calculation to Trial Run	
	Technical Data	152
	Calculation Bases	153

SIMPLICITY® PLANE BEARINGS - INCH SERIES

	PS & PSF Sleeve	154-155
---	-----------------------	---------

SIMPLICITY® PLANE BEARINGS - ISO METRIC

	PSM & PSFM Sleeve	156-157
--	-------------------------	---------



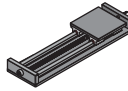
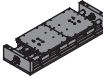
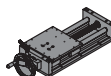
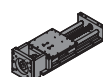
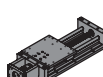

SIMPLICITY® LINEAR SLIDES - INCH SERIES

	Technical Information	158-159
	Load Capacities	160-161
	SRB	162
	Preassembled Shaft, Rail & Bearing	
	RS	163
	Rail Mounted Slide Assembly	
	RPS	164-165
	Rail Mounted & Plate Supported Slide Assembly	
	1RPS	166-167
	Rail Mounted & Plate Supported Ball Screw Driven Slide Assembly	
	2RPS	168-169
	Rail Mounted Plate Supported Ball Screw Driven Slide Assembly	
	LRPS	170-171
	Low Profile Rail Mounted & Plate Supported Slide Assembly	





	2LRPS	172-173
	Low Profile Rail Mounted & Plate Supported Ball Screw Drive Slide Assembly	
	SC2RPS	174-175
	Self-centering Slide Assembly	
	2HCR/2HWL	176-177
	Slide Assembly with Handcrank & Ball Screw Rotational Lock	
	2N42, 56, 143	178-179
	Slide Assembly/NEMA Drive Kit	
	2N23 & 2N24	180-181
	Slide Assembly/NEMA Drive Kit	
	Column Load Chart	182
	Critical Speed Chart	183

The data and specifications in this publication have been carefully compiled and are believed to be accurate and correct. However, it is the responsibility of the user to determine and ensure the suitability of Pacific Bearing® products for a specific application. Pacific Bearing's only obligation will be to repair or replace without charge, any defective components if returned promptly. No liability is assumed beyond such replacement. *Consult www.pacific-bearing.com for the latest technical updates.







MINI-RAIL® MINIATURE LINEAR GUIDES

	MR Series 184-186 Technical Information		LS/MS Series 190 Technical Information
	MTR Series 187 T-Guides		LS Series 191
	L-LPMS Series 188 Low Profile		MS Series 192
	MRR Series 189 Roller Carriage		

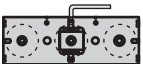
PRECISION POSITION - SLIDES, TABLES, & STAGES

	Product Overview 193		D075 (Small) 196
	DFG Series 194 Dolphin Flex Linear Guide		D100 (Medium) 197
	Product Overview 195		D125 (Large) 198
			Technical Information 199

REDI-RAIL® LINEAR GUIDES

	Adjusting Slider Preload 200 Slider Orientation 200 Lubrication - Rails & Bearings 200 Mounting Slider 200 Life Calculations 200-201 Reduction Factor 201 Load Comparison Graphs 201		RRS30 Slides (Metric) 206
			RR30 Rails (Metric) 207
			RRS45 Slides (Metric) 208
			RR45 Rails (Metric) 209
			RRS65 Slides (Metric) 210
	RRS14 Slides (Inch) 202		RR65 Slides (Metric) 211
	RR14 Rails (Inch) 203		
	RRS18 Slides (Inch) 204		
	RR18 Rails (Inch) 205		

REDI-RAIL® DRAWER SLIDES

	Inch - Product Overview & Application 212		Metric - Product Overview & Application 213
--	--	---	--

REDI-RAIL® STEEL LINEAR GUIDES

	Innovation in Roller Based Linear Systems 214-215 System Life 216 Linear Precision 216 Sizing Control 217 Maintenance 217 Corrosion Resistance 217		RSS18 Slides & RRT18 Rails 218
			RSS28 Slides & RRT28 Rails 219
			RSS43 Slides & RRT43 Rails 220
			Applications 221

The data and specifications in this publication have been carefully compiled and are believed to be accurate and correct. However, it is the responsibility of the user to determine and ensure the suitability of Pacific Bearing® products for a specific application. Pacific Bearing's only obligation will be to repair or replace without charge, any defective components if returned promptly. No liability is assumed beyond such replacement. *Consult www.pacific-bearing.com for the latest technical updates.

REDI-RAIL® DRAWER SLIDES - PRECISION & COMPACT



Precision & Compact Precision	
Product Overview	222
Precision Drawer Slides	
Product Overview	223
RDRS80 & RDRS116	224



Compact Precision Drawer Slides	
Product Overview.....	225
RDQ37	226-227
RDQ57	228-229

REDI-RAIL® FLEXIBLE GUIDE SYSTEM



Rollers 43	230
-------------------------	-----

REDI-RAIL® V-GUIDE



Product Overview	231
Radial Loads to 283 lbs. (1,260 N) per Wheel	232
Radial Loads to 614 lbs. (2,730 N) per Wheel	233

Radial Loads to 1,386 lbs. (6,166 N) per Wheel	234
Radial Loads to 2,246 lbs. (9,991 N) per Wheel	235
Technical Information	236-237

REDI-RAIL® COMMERCIAL RAIL



Product Overview	238
CR20 Slide & Rail	239
Dynamic Radial Cr280 N	

CR30 Slide & Rail	240
Dynamic Radial Cr800 N	
CR45 Slide & Rail	241
Dynamic Radial Cr1,740 N	

REDI-RAIL® HARDENED CROWN ROLLERS



Product Overview	242
-------------------------------	-----

HEVI-RAIL® LINEAR BEARING SYSTEMS



Product Overview	243
0.6 US Ton-Force	244
0.8 US Ton-Force	245
0.9 US Ton-Force	246
1.0 US Ton-Force	247-248
1.7 US Ton-Force	249

1.8 US Ton-Force	250-251
2.6 US Ton-Force	252
4.6 US Ton-Force	253
Applications	254

The data and specifications in this publication have been carefully compiled and are believed to be accurate and correct. However, it is the responsibility of the user to determine and ensure the suitability of Pacific Bearing® products for a specific application. Pacific Bearing's only obligation will be to repair or replace without charge, any defective components if returned promptly. No liability is assumed beyond such replacement. *Consult www.pacific-bearing.com for the latest technical updates.



Simplicity® Self-Lubricating Bearings

Ordering Information

Linear Motion Systems

Plane Ordering Information

SERIES

- FL - Standard Inch Series
- FM - ISO Metric Series
- FMT - Compact ISO Metric Thin Wall Series
- FG - "FAG™" Thin Wall Interchange
- FJ - JIS Standard Series
- PS - Inch Series Sleeve Bearings
- PSF - Inch Series Flange Bearings
- PSM - ISO Metric Series Sleeve Bearings
- PSFM - ISO Metric Series Flange Bearings

O.D. Features

- NOTE:** Available ONLY on the "FL, FM, FJ" series
- No Entry** - Standard Straight O.D. bearing
- A** - Crowned "self-aligning" O.D. bearing (closed only)

I.D. Features

- NOTE:** Does NOT apply to "PS, PSF, PSM, PSFM"
- No Entry** - Standard Precision running clearance on the I.D.
- C** - Compensated running clearance on the I.D.

Closed or Open Style

- No Entry** - Standard Closed bearing
- N** - Open series bearing (not available in "FLA")
- NOTE:** Available ONLY on the "FL, FM, FJ" series

Bearing Shell Material

- NOTE:** Available ONLY on "FL, FM, FMT, FG, FJ" series
- No Entry** - Standard Aluminum Alloy
- *S** - 316 Stainless Steel (**NOTE:** No finish plating or anodize available)

Nominal Shaft Diameter

- NOTE:** English units in 16ths of an inch
- Metric units in mm

FL A C N S 16 - D E JKM Q

Seal Options

- NOTE:** Available only with "FL, FM, FJ" series.
- D** - Double seals of Standard Polymod material
- DU** - Double seals of moly impregnated urethane material
- DV** - Double seals of viton - high temperature material
- NOTE:** Available size FL08-FL32 and FM20-FM80

Bearing Liner Material

- No Entry** - Standard FrelonGOLD® liner for hardened steel shafting and Feather Shafting®
- *E** - Special FrelonJ® liner for soft shafting (aluminum, 300 series stainless steel, etc.)
- *Limited availability may require special quote**

Internal Lubrication

- NOTE:** Available with "FL, FM and FJ" series only.
- No Entry** - Standard bearing - NO lube system
- JKM** - Thru hole, and internal felt wick to help lubrication retention and flow. (**NOTE:** Zerk fitting added to O.D. of PAC & PACM)
- NOTE:** Available for size "FM12 - FM80" only.

Special Modifications

- NOTE:** Consult Factory
- No Entry** - Standard Options
- Q** - Shipped Oil Free (Consult Factory)

CAUTION: The catalog is designed to represent all possibilities, however may not all be standard parts.

*These are options only - combination could lead to unavailable options.

The data and specifications in this publication have been carefully compiled and are believed to be accurate and correct. However, it is the responsibility of the user to determine and ensure the suitability of Pacific Bearing® products for a specific application. Pacific Bearing's only obligation will be to repair or replace without charge, any defective components if returned promptly. No liability is assumed beyond such replacement. *Consult www.pacific-bearing.com for the latest technical updates.



Simplicity® Self-lubricating Bearings

Ordering Information

Linear Motion Systems

Plane Ordering Information

SERIES

NOTE: Standard Simplicity bearings are installed in housings

P - Standard Inch Series Pillow Blocks (FL)
PW - Inch Series Twin Pillow Blocks (FL)
PM - ISO Metric Pillow Blocks (FM)
SDS - Single Steel Flange Mount Die Set Series (FL)
DDS - Double Steel Flange Mount Die Set Series (FL)
SFP - Inch Series Single Aluminum Flange Mounts (FL)
DFF - Inch Series Double Aluminum Flange Mounts (FL)
PAC - Inch Series Die Set Bushings
PACM - ISO Metric Series Die Set Bushings
SFPM - ISO Metric Series Single Aluminum Flange Mounts
DFPM - ISO Metric Series Double Aluminum Flange Mounts
CFPM - ISO Metric Series Double Aluminum Center Flange Mounts
SFPJ - JIS Metric Series Single Aluminum Flange Mounts
DFFJ - JIS Metric Series Double Aluminum Flange Mounts
CFPJ - JIS Metric Series Double Aluminum Center Flange Mounts

Closed or Open Style

NOTE: Available ONLY on "P, PW, PM" series
No Entry - Standard Closed Series
N - Open Series

Housing I.D. Features

No Entry - Standard Spherical "self-aligning" I.D. in the housing. (Uses standard straight O.D. bearings)
B - Straight I.D. housing. (For rigid fit use standard bearing. For self-alignment use "FLA" bearings.)
No Entry - Standard Square Flange
R - Available Round Flange
NOTE: Available ONLY on "SFPM, DFPM, CFPM, SFPJ, DFFJ, CFPJ" series

Housings Only

No Entry - Housings with bearing included
E - Empty Housings with NO bearing included

Nominal Shaft Diameter

NOTE: English units in 16ths of an inch
 Metric units in mm



Bearing I.D. Features

No Entry - Standard Precision running clearance on the I.D.
C - Compensated running clearance on the I.D.

Seal Options

NOTE: "PAC" and "PACM" available ONLY as "S, SU, or SV"
D - Double seals of Standard Polymod material
DU - Double seals of moly impregnated urethane material
DV - Double seals of viton - high temperature material

Bearing Liner Material

No Entry - Standard FrelonGOLD® liner for hardened steel shafting and Feather Shafting®
E - Special FrelonJ® liner for soft shafting (aluminum, 300 series stainless steel, 440 stainless steel shafting)

Internal Lubrication

No Entry - Standard pillowblock assembly with NO lubrication system
JKM - Thru holes, and internal felt wick to help lubrication retention and flow 1/4-28 Zerk.

Special Modifications

NOTE: Consult Factory
No Entry - Standard Options
Q - Shipped Oil Free (Consult Factory)

CAUTION: The catalog is designed to represent all possibilities, however may not all be standard parts.

*These are options only - combination could lead to unavailable options.

The data and specifications in this publication have been carefully compiled and are believed to be accurate and correct. However, it is the responsibility of the user to determine and ensure the suitability of Pacific Bearing® products for a specific application. Pacific Bearing's only obligation will be to repair or replace without charge, any defective components if returned promptly. No liability is assumed beyond such replacement. *Consult www.pacific-bearing.com for the latest technical updates.



Simplicity® Self-Lubricating Bearings

Linear Bearings - Inch Series

Linear Motion Systems

Self-lubricating Bearings

FL LINEAR BEARINGS

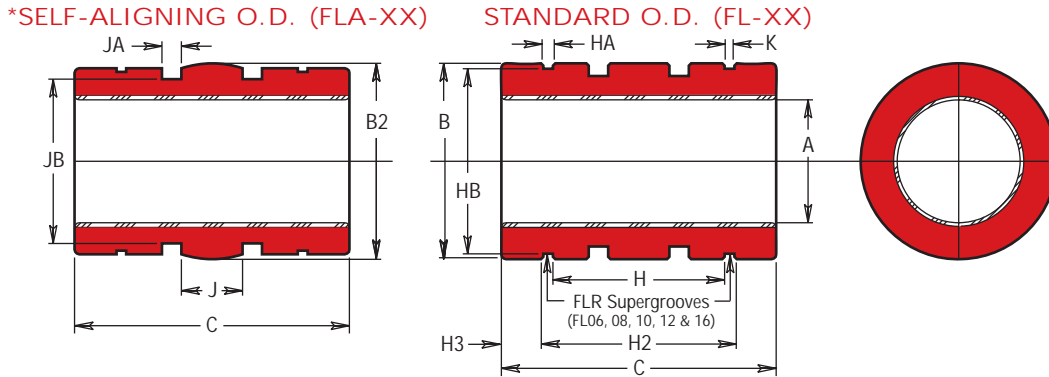

*Except for the O.D., bearings with the self-aligning feature have the same dimensions and tolerances as the standard bearing. There is a spherical crown on the O.D. to create the self-aligning feature. They are for use in a straight bore housing. Add an "A" to the part number per the example. More information on self-aligning bearings is on pages 41-42.

BASIC DIMENSIONAL INFORMATION

PRECISION I.D. SERIES Similar to preloaded ball bearing					COMPENSATED I.D. SERIES Allows additional running clearance					B2		C			CONCENTRIC	BEARING WEIGHT (lbs.)	K FLR RET. RING GR.
PART NO.		NOMINAL SIZE	A BEARING I.D.		PART NO.		A BEARING I.D.		B STANDARD O.D.		SELF-ALIGNING FLA CROWN O.D.		MIN.	MAX.			
CLOSED	OPEN	(in.)	MIN.	MAX.	CLOSED	OPEN	MIN.	MAX.	MIN.	MAX.	MIN.	MAX.	MIN.	MAX.	MAX.		
FL 03	N / A	3/16	0.1877	0.1884	FLC 03	N / A	0.1897	0.1904	0.3740	0.3750	0.3725	0.3735	0.5470	0.5620	0.0010	0.0030	N / A
FL 04	FLN 04	1/4	0.2502	0.2511	FLC 04	FLCN 04	0.2522	0.2531	0.4990	0.5000	0.4975	0.4985	0.7350	0.7500	0.0010	0.0090	N / A
FL 06	FLN 06	3/8	0.3752	0.3761	FLC 06	FLCN 06	0.3772	0.3781	0.6240	0.6250	0.6225	0.6235	0.8600	0.8750	0.0010	0.0160	0.0720
FL 08	FLN 08	1/2	0.5002	0.5013	FLC 08	FLCN 08	0.5022	0.5033	0.8740	0.8750	0.8725	0.8735	1.2350	1.2500	0.0010	0.0410	0.0800
FL 10	FLN 10	5/8	0.6252	0.6263	FLC 10	FLCN 10	0.6272	0.6283	1.1240	1.1250	1.1225	1.1235	1.4850	1.5000	0.0010	0.0910	N / A
FL 12	FLN 12	3/4	0.7503	0.7516	FLC 12	FLCN 12	0.7533	0.7546	1.2490	1.2500	1.2475	1.2485	1.6100	1.6250	0.0010	0.1090	0.1710
FL 16	FLN 16	1	1.0003	1.0016	FLC 16	FLCN 16	1.0033	1.0046	1.5613	1.5625	1.5599	1.5609	2.2350	2.2500	0.0010	0.2280	0.1330
FL 20	FLN 20	1-1/4	1.2504	1.2519	FLC 20	FLCN 20	1.2544	1.2559	1.9988	2.0000	1.9974	1.9984	2.6100	2.6250	0.0010	0.4590	N / A
FL 24	FLN 24	1-1/2	1.5004	1.5019	FLC 24	FLCN 24	1.5044	1.5059	2.3738	2.3750	2.3724	2.3734	2.9850	3.0000	0.0010	0.7250	N / A
FL 32	FLN 32	2	2.0004	2.0022	FLC 32	FLCN 32	2.0054	2.0072	2.9986	3.0000	2.9973	2.9983	3.9850	4.0000	0.0010	1.4420	N / A
FL 40	FLN 40	2-1/2	2.5004	2.5022	FLC 40	FLCN 40	2.5054	2.5072	3.7484	3.7500	3.7472	3.7482	4.9850	5.0000	0.0013	2.8160	N / A
FL 48	FLN 48	3	3.0004	3.0022	FLC 48	FLCN 48	3.0064	3.0082	4.4980	4.5000	4.4970	4.4980	5.9850	6.0000	0.0015	4.9140	N / A
FL 64	FLN 64	4	4.0005	4.0026	FLC 64	FLCN 64	4.0065	4.0086	5.9980	6.0000	5.9970	5.9980	7.9850	8.0000	0.0020	11.8360	N / A

MOUNTING DIMENSIONAL INFORMATION

PART NO.		NOMINAL SIZE	H	HA	HB	TRUARC RET. RING PART NO.	J	JA	JB	PARKER O-RING PART NO.	H2	H3
CLOSED	OPEN	(IN.)	BETWEEN RET. RINGS	RET. RING GRV. WIDTH	RET. RING GRV. DIA.		BETWEEN O-RING GRVS.	O-RING GRV. WIDTH	O-RING GRV. DIA.		FLR BETWEEN RINGS	FLR RING EDGE
FL 03	N / A	3/16	0.375	0.030	0.352	N 5100-37	N / A	N / A	N / A	N / A	N / A	N / A
FL 04	FLN 04	1/4	0.437	0.041	0.467	N 5100-50	0.125	0.080	0.399	2-010	N / A	N / A
FL 06	FLN 06	3/8	0.562	0.041	0.587	N 5100-62	0.187	0.080	0.524	2-012	.711/.701	0.081
FL 08	FLN 08	1/2	0.875	0.048	0.820	N 5100-87	0.250	0.125	0.712	2-113	1.042/1.032	0.103
FL 10	FLN 10	5/8	1.000	0.058	1.060	N 5100-112	0.312	0.125	0.962	2-117	N / A	N / A
FL 12	FLN 12	3/4	1.062	0.058	1.177	N 5100-125	0.312	0.125	1.087	2-119	1.281/1.271	0.171
FL 16	FLN 16	1	1.625	0.070	1.471	N 5100-156	0.500	0.125	1.399	2-123	1.895/1.885	0.176
FL 20	FLN 20	1-1/4	1.875	0.070	1.889	N 5100-200	0.625	0.125	1.837	2-129	N / A	N / A
FL 24	FLN 24	1-1/2	2.250	0.089	2.241	N 5100-237	0.750	0.162	2.152	2-225	N / A	N / A
FL 32	FLN 32	2	3.000	0.105	2.839	N 5100-300	1.000	0.189	2.775	2-229	N / A	N / A
FL 40	FLN 40	2-1/2	3.750	0.123	3.553	N 5100-375	1.250	0.250	3.408	2-340	N / A	N / A
FL 48	FLN 48	3	4.500	0.123	4.309	N 5100-450	1.500	0.287	4.158	2-346	N / A	N / A
FL 64	FLN 64	4	6.000	0.145	5.748	N 5100-600	2.000	0.287	5.660	2-356	N / A	N / A

NOTES: FLR is not available on FL03 and FL04.

FLR is only available on FL06, FL08, FL10, FL12 and FL16.

The data and specifications in this publication have been carefully compiled and are believed to be accurate and correct. However, it is the responsibility of the user to determine and ensure the suitability of Pacific Bearing® products for a specific application. Pacific Bearing's only obligation will be to repair or replace without charge, any defective components if returned promptly. No liability is assumed beyond such replacement. *Consult www.pacific-bearing.com for the latest technical updates.



FL & FLN LINEAR BEARINGS

FLN 04 - FLN 06

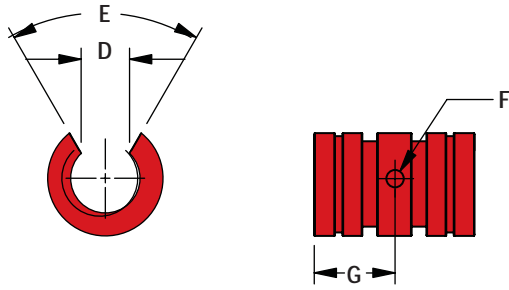

FLN 08

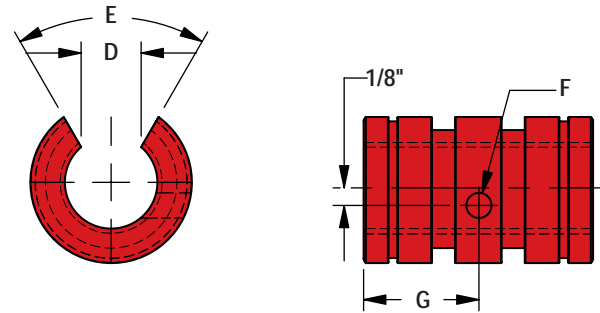

FLN 10

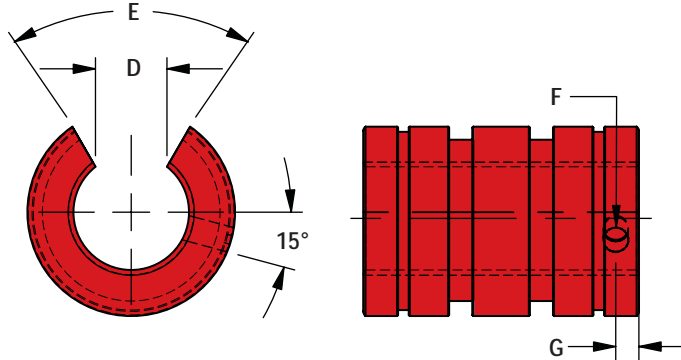

FLN 12 THRU FLN 64

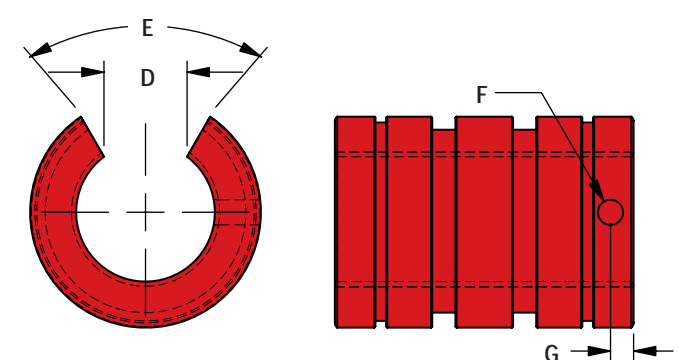

OPEN DIMENSIONAL INFORMATION

PART NO.		NOMINAL SIZE	D SLOT WIDE MIN.	E SLOT ANGLE	F RETAINING HOLE DIA.	G RETAINING HOLE LOCATE	BEARING WEIGHTS
PRECISION	COMPENSATED	(in.)				(in.)	(lbs.)
FLN 04	FLCN 04	1/4	0.188	60°	0.094	3/8	0.008
FLN 06	FLCN 06	3/8	0.250	60°	0.094	7/16	0.013
FLN 08	FLCN 08	1/2	0.313	60°	0.136	5/8	0.034
FLN 10	FLCN 10	5/8	0.375	60°	0.136	1/8	0.072
FLN 12	FLCN 12	3/4	0.438	60°	0.136	1/8	0.091
FLN 16	FLCN 16	1	0.563	60°	0.136	1/8	0.184
FLN 20	FLCN 20	1-1/4	0.625	60°	0.201	3/16	0.381
FLN 24	FLCN 24	1-1/2	0.750	60°	0.201	3/16	0.603
FLN 32	FLCN 32	2	1.000	60°	0.265	5/16	1.192
FLN 40	FLCN 40	2-1/2	1.250	60°	0.265	5/16	2.334
FLN 48	FLCN 48	3	1.500	60°	0.265	5/16	4.080
FLN 64	FLCN 64	4	2.000	60°	0.265	5/16	9.870

NOTE: All other dimensions same as closed bearing.

- Retaining Ring Grooves 10
- Pillow Block Information..... 12-13
- Sleeve Bearings 154-155
- Flange Mount Housing Information 14
- Flange Mount Die Sets..... 15
- Die Set Bushings 24
- Shafting, Support Blocks and Rails 63

FrelonGOLD® and FrelonJ® are registered trademarks of Pacific Bearing.

The data and specifications in this publication have been carefully compiled and are believed to be accurate and correct. However, it is the responsibility of the user to determine and ensure the suitability of Pacific Bearing® products for a specific application. Pacific Bearing's only obligation will be to repair or replace without charge, any defective components if returned promptly. No liability is assumed beyond such replacement. *Consult www.pacific-bearing.com for the latest technical updates.

LOAD & SPEED DATA

PART NO.	EFFECTIVE SURFACE AREA (sq. in.)	MAX. STATIC LOAD FRELON	
		GOLD (lbs.)	J (lbs.)
FL 03	0.110	220	100
FL 04	0.200	600	300
FL 06	0.340	1020	510
FL 08	0.650	1950	975
FL 10	0.980	2940	1470
FL 12	1.270	3810	1905
FL 16	2.350	7050	3525
FL 20	3.430	10830	5415
FL 24	4.700	14100	7050
FL 32	8.350	25050	12525
FL40	13.000	39000	19500
FL 48	18.800	56400	28200
FL 64	33.500	100500	50250

<p>MAX. PV (ft./min. * psi) FrelonGold = 20000 PV FrelonJ = 10000 PV</p> <p>MAX. Speed Running Dry (ft./min.) FrelonGold = 300 sfm FrelonJ = 140 sfm</p> <p>MAX. Speed Running with Lubrication (ft./min.) FrelonGold = 825 sfm FrelonJ = 400 sfm</p>
--



Simplicity® Self-lubricating Bearings

Pillow Blocks - Inch Series

Linear Motion Systems

Pillow Blocks

P & PN PILLOW BLOCKS

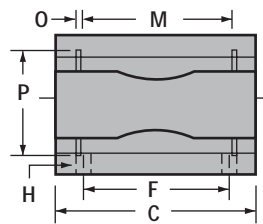
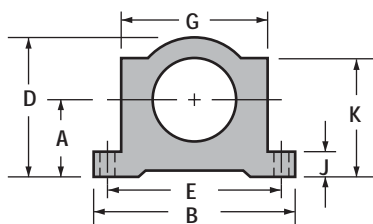
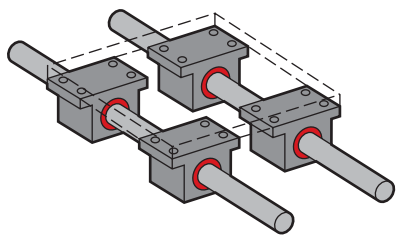

CLOSED PILLOW BLOCKS

PART NO. CLOSED	NOM. BRG. I.D.	A CENTERLINE	B	C	D	E	F	G BODY	H	J FLNG. THICK	K	M GRV. SPACE	O GRV. WIDTH	P GRV. DIA.	SMALLEY RET. RING PART NO.	MAX. STATIC LOAD (lbs.) FRELON		ASSEM. WT. (lbs.)		
																GOLD	J			
P 04	P 04C	1/4"	0.437	1.625	1.19	0.813	1.312	0.750	1.000	#6	5/32"	0.188	0.750	0.750	0.039	0.532	WH-51	600	300	0.099
P 06	P 06C	3/8"	0.500	1.750	1.31	0.938	1.437	0.875	1.125	#6	5/32"	0.188	0.875	0.875	0.039	0.665	WH-65	1020	510	0.129
P 08	P 08C	1/2"	0.687	2.000	1.69	1.250	1.688	1.000	1.375	#6	5/32"	0.250	1.125	1.250	0.046	0.931	WH-90	1950	975	0.250
P 10	P 10C	5/8"	0.875	2.500	1.94	1.625	2.125	1.125	1.750	#8	3/16"	0.281	1.438	1.500	0.056	1.197	WH-115	2940	1470	0.500
P 12	P 12C	3/4"	0.937	2.750	2.06	1.750	2.375	1.250	1.875	#8	3/16"	0.313	1.563	1.625	0.056	1.330	WH-128	3710	1905	0.580
P 16	P 16C	1"	1.187	3.250	2.81	2.188	2.875	1.750	2.375	#10	7/32"	0.375	1.938	2.250	0.068	1.671	WH-156	7050	3525	1.000
P 20	P 20C	1-1/4"	1.500	4.000	3.63	2.813	3.500	2.000	3.000	#10	7/32"	0.438	2.500	2.625	0.068	2.122	WH-200	10290	5145	2.000
P 24	P 24C	1-1/2"	1.750	4.750	4.00	3.250	4.125	2.500	3.500	1/4"	9/32"	0.500	2.875	3.000	0.086	2.519	WH-237	14100	7050	3.000
P 32	P 32C	2"	2.125	6.000	5.00	4.063	5.250	3.250	4.500	3/8"	13/32"	0.625	3.625	4.000	0.103	3.182	WH-300	25050	12525	6.500

- NOTES: (1) Standard, pre-assembled pillow blocks include self-aligning housing and precision bearing.
 (2) All standard pillow blocks use standard "FL" series bearings found on page 10.
 (3) Straight bore, pre-assembled pillow blocks use standard "FL" series bearing.

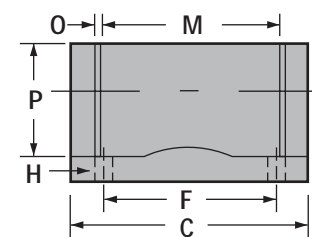
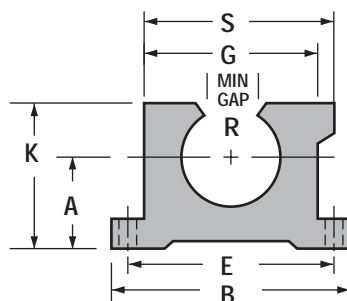
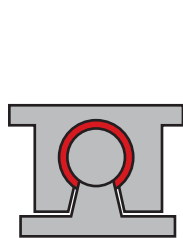
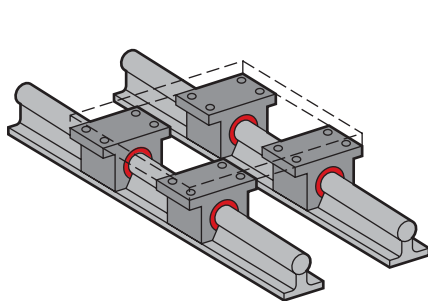

OPEN PILLOW BLOCKS

PART NO. CLOSED	NOM. BRG. I.D.	A CENTERLINE	B	C	E	F	G BODY	H	J FLNG. THICK	K	M GRV. SPACE	O GRV. WIDTH	P GRV. DIA.	R MIN.	EATON RET. RING PART NO.	MAX. STATIC LOAD (lbs.) FRELON		ASSEM. WT. (lbs.)	S OVERALL WIDTH		
																GOLD	J				
PN 08	PN 08C	1/2"	0.687	2.000	1.50	1.688	1.000	1.375	#6	5/32"	0.250	1.125	1.250	0.046	0.931	0.313	MNAN-87	1950	975	0.250	1.438
PN 10	PN 10C	5/8"	0.875	2.500	1.75	2.125	1.125	1.750	#8	3/16"	0.281	1.438	1.500	0.056	1.197	0.375	MNAN-112	2940	1470	0.500	1.813
PN 12	PN 12C	3/4"	0.937	2.750	1.88	2.375	1.250	1.875	#8	3/16"	0.313	1.563	1.625	0.056	1.330	0.438	MNAN-125	3710	1905	0.580	1.938
PN 16	PN 16C	1"	1.187	3.250	2.63	2.875	1.750	2.375	#10	7/32"	0.375	1.938	2.250	0.068	1.671	0.563	MNAN-156	7050	3525	1.000	2.438
PN 20	PN 20C	1-1/4"	1.500	4.000	3.38	3.500	2.000	3.000	#10	7/32"	0.438	2.500	2.625	0.068	2.122	0.625	MNAN-200	10290	5145	2.000	3.125
PN 24	PN 24C	1-1/2"	1.750	4.750	3.75	4.125	2.500	3.500	1/4"	9/32"	0.500	2.875	3.000	0.086	2.519	0.750	MNAN-237	14100	7050	3.000	3.625
PN 32	PN 32C	2"	2.125	6.000	4.75	5.250	3.250	4.500	3/8"	13/32"	0.625	3.625	4.000	0.103	3.182	1.000	MNAN-300	25050	12525	6.500	4.688

- NOTES: (1) Standard, pre-assembled pillow blocks include self-aligning housing and precision bearing.
 (2) All standard pillow blocks use standard "FL" series bearings found on page 10.
 (3) All open pillow blocks have "notch".

FrelonGOLD® and FrelonJ® are registered trademarks of Pacific Bearing.

See Page 162 for SRB Series – Preassembled Pillow Block, Shaft and Support Rail.

The data and specifications in this publication have been carefully compiled and are believed to be accurate and correct. However, it is the responsibility of the user to determine and ensure the suitability of Pacific Bearing® products for a specific application. Pacific Bearing's only obligation will be to repair or replace without charge, any defective components if returned promptly. No liability is assumed beyond such replacement. *Consult www.pacific-bearing.com for the latest technical updates.

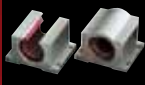

PW & PWN TWIN PILLOW BLOCKS

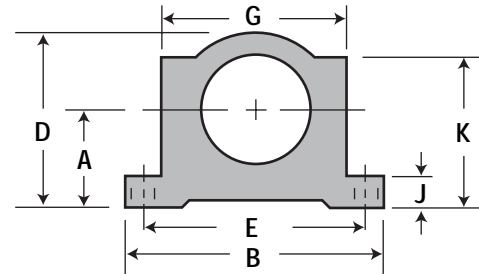
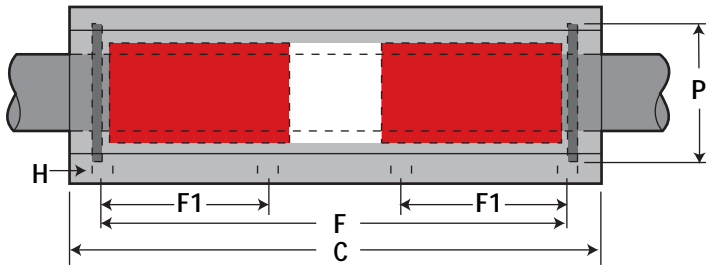

TWIN CLOSED PILLOW BLOCKS

PART NO. CLOSED	NOM. BRG. I.D.	A CENTERLINE	B WIDTH	C LENGTH	D HEIGHT	E +/- .010	F +/- .010	F1 +/- .010	G BODY WIDTH	H BOLT	HOLE	J FLNG. THICK	K	P GRV. DIA.	SMALLEY RET. RING PART NO.	MAX. STATIC LOAD (lbs.) FRELON		ASSEM. WT. (lbs.)	
																GOLD	J		
PW 04	PW 04C	1/4"	0.437	1.625	2.500	0.813	1.3120	2.0000	.750	1.000	#6	5/32"	0.188	0.750	0.532	WH-51	1200	600	0.197
PW 06	PW 06C	3/8"	0.500	1.750	2.750	0.938	1.4370	2.2500	.875	1.125	#6	5/32"		0.875	0.665	WH-65	2040	1020	0.258
PW 08	PW 08C	1/2"	0.687	2.000	3.500	1.250	1.6880	2.5000	1.000	1.375	#6	5/32"	0.250	1.125	0.931	WH-90	3900	1950	0.500
PW 10	PW 10C	5/8"	0.875	2.500	4.000	1.625	2.1250	3.0000	1.125	1.750	#8	3/16"	0.281	1.438	1.197	WH-115	5880	2940	1.000
PW 12	PW 12C	3/4"	0.937	2.750	4.500	1.750	2.3750	3.5000	1.250	1.875	#8	3/16"	0.313	1.563	1.330	WH-128	7620	3810	1.125
PW 16	PW 16C	1"	1.187	3.250	6.000	2.188	2.8750	4.5000	1.750	2.375	#10	7/32"	0.375	1.938	1.671	WH-156	14100	7050	2.188
PW 20	PW 20C	1-1/4"	1.500	4.000	7.500	2.813	3.5000	5.5000	2.000	3.000	#10	7/32"	0.438	2.500	2.122	WH-200	20580	10290	4.250
PW 24	PW 24C	1-1/2"	1.750	4.750	9.000	3.250	4.1250	6.5000	2.500	3.500	1/4"	9/32"	0.500	2.875	2.519	WH-237	28200	14100	6.375
PW 32	PW 32C	2"	2.125	6.000	10.000	4.063	5.2500	8.2500	3.250	4.500	3/8"	13/32"	0.625	3.625	3.182	WH-300	50100	25050	13.500

- NOTES: (1) Standard, pre-assembled pillow blocks include self-aligning housing and precision bearing.
 (2) All standard pillow blocks use standard "FL" series bearings found on page 10.
 (3) Twin Closed Pillow Blocks use a spacer to separate the bearings.
 (4) Twin pillow blocks, closed, with no seal option: Use (2) standard bearings, based on compensated or std option.
 (5) Twin pillow blocks, closed, with double seal option: Use (2) single seal bearings.

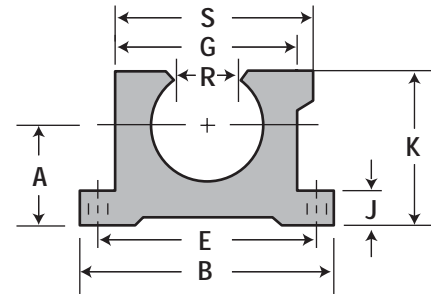
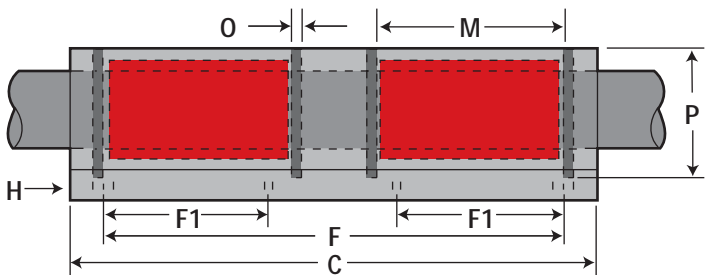

TWIN OPEN PILLOW BLOCKS

PART NO. CLOSED	NOM. BRG. I.D.	A CENTERLINE	B WIDTH	C LENGTH	E +/- .010	F +/- .010	F1 +/- .010	G BODY WIDTH	H BOLT	HOLE	J FLNG. THICK	K HEIGHT	M GRV. SPACE	O GRV. WIDTH	P GRV. DIA.	R MIN. OPEN	EATON RET. RING PART NO.	MAX. STATIC LOAD (lbs.) FRELON		ASSEM. WT. (lbs.)	S OVERALL WIDTH	
																		GOLD	J			
PWN 08	PWN 08C	1/2"	0.687	2.000	3.500	1.688	2.500	1.000	1.375	#6	5/32"	0.250	1.125	1.250	0.046	0.931	0.313	MNAN-87	3900	1950	0.400	1.438
PWN 10	PWN 10C	5/8"	0.875	2.500	4.000	2.125	3.000	1.125	1.750	#8	3/16"	0.281	1.438	1.500	0.056	1.197	0.375	MNAN-112	5880	2940	0.910	1.813
PWN 12	PWN 12C	3/4"	0.937	2.750	4.500	2.375	3.500	1.250	1.875	#8	3/16"	0.313	1.563	1.625	0.056	1.330	0.438	MNAN-125	7620	3810	1.060	1.938
PWN 16	PWN 16C	1"	1.187	3.250	6.000	2.875	4.500	1.750	2.375	#10	7/32"	0.375	1.938	2.250	0.068	1.671	0.563	MNAN-156	14100	7050	1.970	2.438
PWN 20	PWN 20C	1-1/4"	1.500	4.000	7.500	3.500	5.500	2.000	3.000	#10	7/32"	0.438	2.500	2.625	0.068	2.122	0.625	MNAN-200	20580	10290	3.725	3.125
PWN 24	PWN 24C	1-1/2"	1.750	4.750	9.000	4.125	6.500	2.500	3.500	1/4"	9/32"	0.500	2.875	3.000	0.086	2.519	0.750	MNAN-237	28200	14100	5.800	3.625
PWN 32	PWN 32C	2"	2.125	6.000	10.000	5.250	8.250	3.250	4.500	3/8"	13/32"	0.625	3.625	4.000	0.103	3.182	1.000	MNAN-300	50100	25050	12.125	4.688

- NOTES: (1) Standard, pre-assembled pillow blocks include self-aligning housing and precision bearing.
 (2) All standard pillow blocks use standard "FL" series bearings found on page 10.
 (3) All open pillow blocks have "notch".
 (4) Twin pillowblocks, open, with no seal option: Use (2) standard open bearings, based on compensated or std option.
 (5) Twin pillowblocks, open, with double seal option: Use (2) double seal bearings.

FrelonGOLD® and FrelonJ® are registered trademarks of Pacific Bearing.

See Page 162 for SRB Series – Preassembled Pillow Block, Shaft and Support Rail.

The data and specifications in this publication have been carefully compiled and are believed to be accurate and correct. However, it is the responsibility of the user to determine and ensure the suitability of Pacific Bearing® products for a specific application. Pacific Bearing's only obligation will be to repair or replace without charge, any defective components if returned promptly. No liability is assumed beyond such replacement. *Consult www.pacific-bearing.com for the latest technical updates.



SFP FLANGE MOUNTS

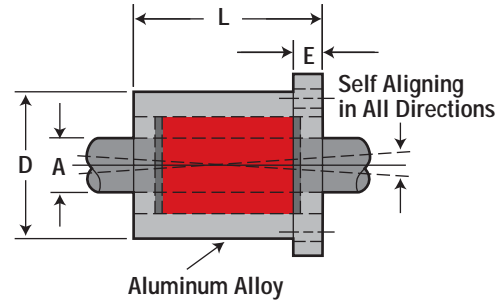
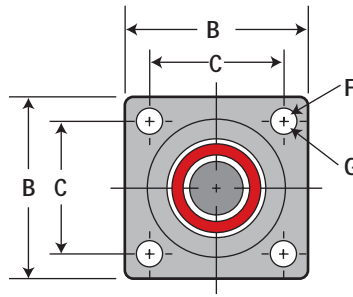

BASIC DIMENSIONAL INFORMATION

PART NO.		A BEARING NOMINAL SIZE	B FLANGE SQUARE	C HOLE SPACING	D BARREL DIA.	E FLANGE LENGTH	F BOLT SIZE	G HOLE SIZE	L LENGTH OVERALL	MAX. STATIC LOAD (lbs.) FRELON		ASSEMBLY WEIGHT (lbs.)
PRECISION	COMPENSATED									GOLD	J	
SFP 08	SFP 08 C	1/2"	1.63	1.25	1.25	0.250	#8	0.187	1.687	1950	975	0.175
SFP 12	SFP 12 C	3/4"	2.38	1.75	1.75	0.375	#10	0.219	2.067	2940	1470	0.463
SFP 16	SFP 16 C	1"	2.75	2.125	2.25	0.500	1/4"	0.281	2.812	3810	1905	1.206

NOTES: All standard, pre-assembled "SFP" assemblies include a self-aligning housing and standard "FL" bearings found on page 10.
Straight bore "SFPB" assemblies include a straight bore housing and standard "FL" bearings.

DFP FLANGE MOUNTS

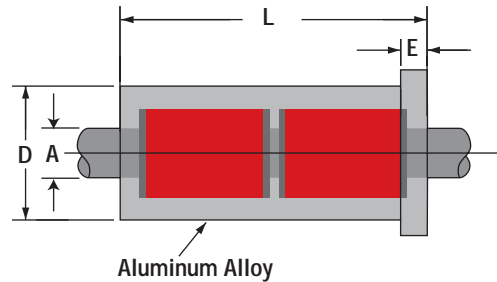
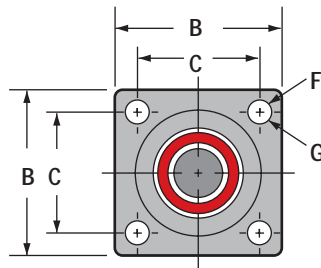

BASIC DIMENSIONAL INFORMATION

PART NO.		A BEARING NOMINAL SIZE	B FLANGE SQUARE	C HOLE SPACING	D BARREL DIA.	E FLANGE LENGTH	F BOLT SIZE	G HOLE SIZE	L LENGTH OVERALL	MAX. STATIC LOAD (lbs.) FRELON		ASSEMBLY WEIGHT (lbs.)
PRECISION	COMPENSATED									GOLD	J	
DFP 08	DFP 08 C	1/2"	1.63	1.25	1.25	0.250	#8	0.187	3.375	3900	1950	0.325
DFP 12	DFP 12 C	3/4"	2.38	1.75	1.75	0.375	#10	0.219	4.188	5880	2940	0.825
DFP 16	DFP 16 C	1"	2.75	2.125	2.25	0.500	1/4"	0.281	5.625	7620	3810	1.750

NOTES: All standard, pre-assembled "DFP" assemblies include a self-aligning housing and standard "FL" bearings found on page 10.
Straight bore "DFPB" assemblies include a straight bore housing and standard "FL" bearings.

The data and specifications in this publication have been carefully compiled and are believed to be accurate and correct. However, it is the responsibility of the user to determine and ensure the suitability of Pacific Bearing® products for a specific application. Pacific Bearing's only obligation will be to repair or replace without charge, any defective components if returned promptly. No liability is assumed beyond such replacement. *Consult www.pacific-bearing.com for the latest technical updates.



Simplicity® Self-lubricating Bearings

Flange Mount Die Sets - Inch Series

Linear Motion Systems

SDS FLANGE MOUNTS

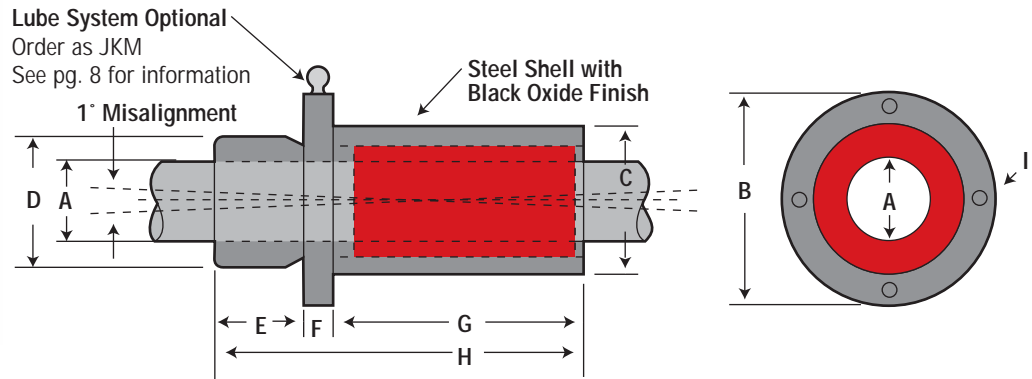

Flange Mount Die Sets

BASIC DIMENSIONAL INFORMATION

PART NO.		A BEARING NOMINAL SIZE	B FLANGE O.D.	C BARREL DIA.		D PILOT DIA.		E PILOT LENGTH	F FLANGE LENGTH	G HEAD LENGTH	H OVERALL LENGTH	I MOUNTING HOLES (4 PLACES)			MAX. STATIC LOAD (lbs.) FRELON		ASSEMBLY WEIGHT (lbs.)
PRECISION	COMPEN.			MIN.	MAX.	MIN.	MAX.					BOLT SIZE	HOLE SIZE	CIRCLE	GOLD	J	
SDS 16	SDS 16 C	1"	3.00	2.098	2.100	1.4995	1.500	0.875	0.562	2.500	3.927	1/4"	0.281	2.550	7050	3525	2.431
SDS 20	SDS 20 C	1-1/4"	3.50	2.598	2.600	1.7495	1.750	1.125	0.750	3.000	4.875	1/4"	0.281	3.050	10290	5145	4.400
SDS 24	SDS 24 C	1-1/2"	4.25	2.998	3.000	1.9990	2.000	1.375	1.000	3.500	5.875	3/8"	0.406	3.650	14100	7050	7.238
SDS 32	SDS 32 C	2"	5.00	3.748	3.750	2.4990	2.500	1.625	1.000	4.500	7.125	3/8"	0.406	4.400	25050	12525	11.788

NOTES: All standard, pre-assembled "SDS" assemblies include a straight bore housing and standard "FLA" bearings found on page 10.

All straight bore, pre-assembled "SDSB" assemblies include a straight bore housing and standard "FL" bearings found on page 10.

DDS FLANGE MOUNTS

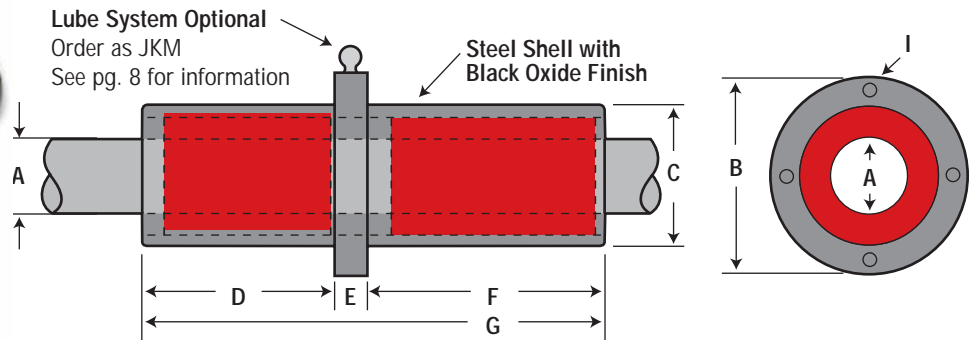

BASIC DIMENSIONAL INFORMATION

PART NO.		A BEARING NOMINAL SIZE	B FLANGE O.D.	C BARREL DIA.		D LENGTH	E FLANGE LENGTH	F LENGTH	G OVERALL LENGTH	I MOUNTING HOLES (4 PLACES)			MAX. STATIC LOAD (lbs.) FRELON		ASSEMBLY WEIGHT (lbs.)
PRECISION	COMPEN.			MIN.	MAX.					BOLT SIZE	HOLE SIZE	CIRCLE	GOLD	J	
DDS 16	DDS 16 C	1"	3.00	2.098	2.100	2.5	0.562	3.500	6.563	1/4"	0.281	2.550	14100	7050	3.823
DDS 20	DDS 20 C	1-1/4"	3.50	2.598	2.600	3	0.750	4.250	8.000	1/4"	0.281	3.050	20580	10290	6.625
DDS 24	DDS 24 C	1-1/2"	4.25	2.998	3.000	3.5	1.000	5.000	9.500	3/8"	0.406	3.650	28200	14100	10.363
DDS 32	SDS 32 C	2"	5.00	3.748	3.750	4.5	1.000	6.500	12.000	3/8"	0.406	4.400	50100	25050	18.400

NOTES: All standard, pre-assembled "DDS" assemblies include a straight bore housing and standard "FLA" bearings found on page 10.

All straight bore, pre-assembled "DDSB" assemblies include a straight bore housing and standard "FL" bearings found on page 10.

The data and specifications in this publication have been carefully compiled and are believed to be accurate and correct. However, it is the responsibility of the user to determine and ensure the suitability of Pacific Bearing® products for a specific application. Pacific Bearing's only obligation will be to repair or replace without charge, any defective components if returned promptly. No liability is assumed beyond such replacement. *Consult www.pacific-bearing.com for the latest technical updates.



Simplicity® Self-Lubricating Bearings

Flange Mount Die Sets - Inch Series

Linear Motion Systems

Flange Mount Die Sets

PAC FLANGE MOUNT DIE SETS

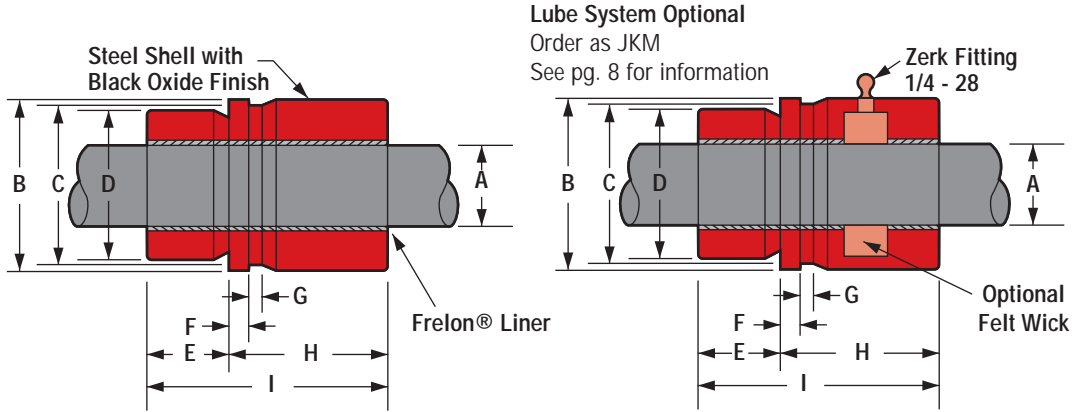

BASIC DIMENSIONAL INFORMATION

PART NO.	NOMINAL SIZE (in.)	A BEARING I.D.		PART NO.	A BEARING I.D.		B FLANGE & BARREL O.D.		C CLAMP DIA.	D PILOT O.D.		E PILOT LENGTH	F FLANGE LENGTH	G RECESS LENGTH	H HEAD LENGTH	I OVERALL LENGTH	EFFECTIVE SURFACE AREA (sq. in.)	MAX STATIC LOAD (lbs.) FRELON		BEARING WEIGHT (lbs.)
		MIN.	MAX.		COMPENSATED	MIN.	MAX.	MIN.		MAX.	MIN.							MAX.	GOLD	
PAC 750	3/4"	0.750	0.7510	PAC 750 C	0.7530	0.7540	1.285	1.300	1.012	1.1245	1.1250	0.812	0.188	0.712	2.000	2.812	2.209	6626	3313	0.625
PAC 100	1"	1.000	1.0010	PAC 100 C	1.0030	1.0040	1.723	1.738	1.450	1.4995	1.5000	0.875	0.188	0.812	2.250	3.125	3.272	9817	4909	1.000
PAC 125	1-1/4"	1.250	1.2510	PAC 125 C	1.2540	1.2550	2.097	2.112	1.825	1.7495	1.7500	1.125	0.188	0.812	2.375	3.500	4.581	13744	6872	1.500
PAC 150	1-1/2"	1.500	1.5012	PAC 150 C	1.5040	1.5050	2.346	2.361	2.075	1.9995	2.0000	1.375	0.188	1.112	2.750	4.125	6.480	19439	9719	2.000
PAC 200	2"	2.000	2.0014	PAC 200 C	2.0050	2.0064	3.095	3.110	2.825	2.4995	2.5000	1.625	0.188	1.112	3.000	4.625	9.687	29060	14530	4.188
PAC 250	2-1/2"	2.500	2.5016	PAC 250 C	2.5050	2.5065	3.595	3.610	3.325	2.9995	3.0000	1.875	0.188	1.112	3.500	5.375	14.072	42215	21108	6.000
PAC 300	3"	3.000	3.0020	PAC 300 C	3.0060	3.0080	4.345	4.360	4.075	3.6245	3.6250	1.875	0.188	1.112	4.000	5.875	18.457	55371	27685	10.000

NOTES: Formula used for effective surface area is $(\pi * ID * L)/3$
 Max Static load is effective surface area times max load for FrelonGOLD®
 - 3000 psi is the rating for FrelonGOLD®
 - 1500 psi is the rating for FrelonJ®

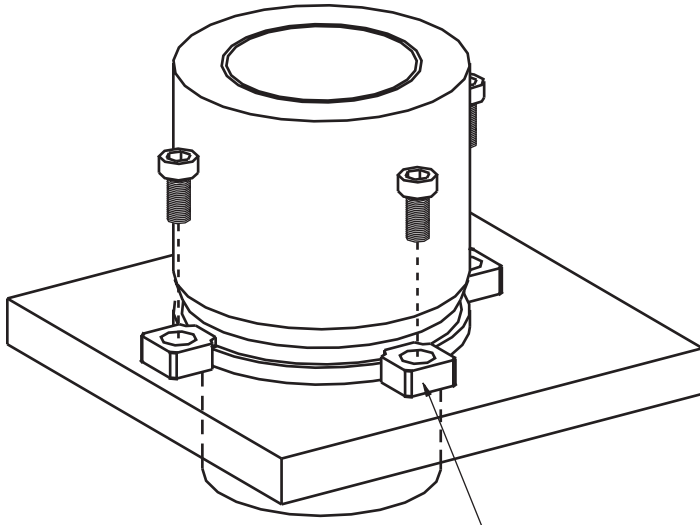

4 PAC CLAMPS ARE SHIPPED WITH EACH DIESET

EXTRAS CAN BE ORDERED USING PART #: PACCLAMP

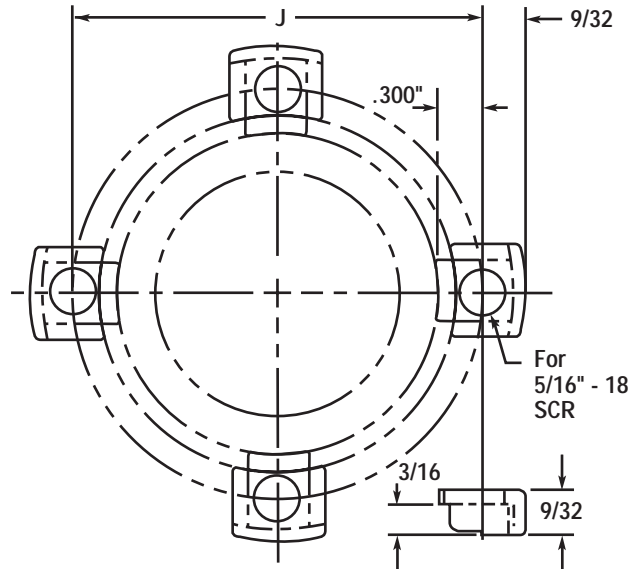

NOTE: DIMENSION FOR CALCULATING BOLT CIRCLE

$$J = C + .600"$$

The data and specifications in this publication have been carefully compiled and are believed to be accurate and correct. However, it is the responsibility of the user to determine and ensure the suitability of Pacific Bearing® products for a specific application. Pacific Bearing's only obligation will be to repair or replace without charge, any defective components if returned promptly. No liability is assumed beyond such replacement. *Consult www.pacific-bearing.com for the latest technical updates.



The data and specifications in this publication have been carefully compiled and are believed to be accurate and correct. However, it is the responsibility of the user to determine and ensure the suitability of Pacific Bearing® products for a specific application. Pacific Bearing's only obligation will be to repair or replace without charge, any defective components if returned promptly. No liability is assumed beyond such replacement. *Consult www.pacific-bearing.com for the latest technical updates.



FM LINEAR BEARINGS

*SELF-ALIGNING O.D. (FMA-XX) STANDARD O.D. (FM-XX)

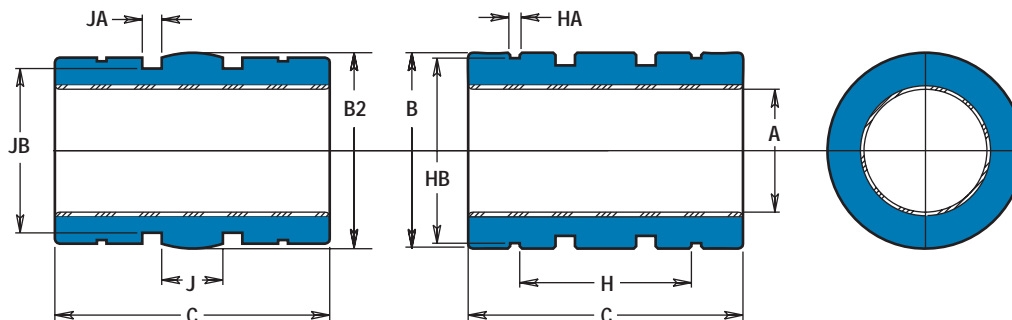

*Except for the O.D., bearings with the self-aligning feature have the same dimensions and tolerances as the standard bearing. There is a spherical crown on the O.D. to create the self-aligning feature. They are used in a straight bore housing. Add an "A" to the part number per the example. More information on self-aligning bearings is on pages 41-42.

BASIC DIMENSIONAL INFORMATION

PRECISION I.D. SERIES Similar to preloaded ball bearing				COMPENSATED I.D. SERIES Similar to standard ball bearing				B O.D. (h7)		FMA		C LENGTH		CONCENTRIC	BEARING WEIGHT	
PART NO.		NOMINAL SIZE	A BEARING I.D. (F8)		PART NO.		A BEARING I.D.			B2 O.D.						
CLOSED	OPEN	(mm)	MIN.	MAX.	CLOSED	OPEN	MIN.	MAX.	MIN.	MAX.	MIN.	MAX.	MIN.	MAX.	MAX. (mm)	(kg.)
FM 05	FMN 05	5	5.010	5.028	FMC 05	FMCN 05	5.060	5.078	11.982	12	11.941	11.966	21.746	22	0.0254	0.004
FM 08	FMN 08	8	8.013	8.035	FMC 08	FMCN 08	8.063	8.085	15.982	16	15.941	15.966	24.746	25	0.0254	0.009
FM 10	FMN 10	10	10.013	10.035	FMC 10	FMCN 10	10.063	10.085	18.979	19	18.938	18.964	28.746	29	0.0254	0.014
FM 12	FMN 12	12	12.016	12.043	FMC 12	FMCN 12	12.066	12.093	21.979	22	21.938	21.963	31.746	32	0.0254	0.017
FM 16	FMN 16	16	16.016	16.043	FMC 16	FMCN 16	16.066	16.093	25.979	26	25.938	25.964	35.746	36	0.0254	0.028
FM 20	FMN 20	20	20.020	20.053	FMC 20	FMCN 20	20.096	20.129	31.975	32	31.938	31.963	44.746	45	0.0254	0.054
FM 25	FMN 25	25	25.020	25.053	FMC 25	FMCN 25	25.096	25.129	39.975	40	39.936	39.962	57.746	58	0.0254	0.109
FM 30	FMN 30	30	30.020	30.053	FMC 30	FMCN 30	30.096	30.129	46.975	47	46.937	46.962	67.746	68	0.0254	0.176
FM 40	FMN 40	40	40.025	40.064	FMC 40	FMCN 40	40.127	40.166	61.970	62	61.935	61.961	79.746	80	0.0254	0.356
FM 50	FMN 50	50	50.025	50.064	FMC 50	FMCN 50	50.127	50.166	74.970	75	74.935	74.960	99.746	100	0.0254	0.628
FM 60	FMN 60	60	60.030	60.076	FMC 60	FMCN 60	60.182	60.228	89.965	90	89.931	89.957	124.492	125	0.0380	1.117
FM 80	FMN 80	80	80.030	80.076	FMC 80	FMCN 80	80.182	80.228	119.965	120	119.931	119.957	164.492	165	0.0510	2.679

MOUNTING DIMENSIONAL INFORMATION

PART NO.		NOMINAL SIZE (mm)	H	HA	HB	RET. RING PART NO. (DIN 471)	J	JA	JB	METRIC O'RING PART NO.
CLOSED	OPEN		BETWEEN RET. RINGS	RET. RING GRV. WIDTH	RET. RING GRV. DIA.		BETWEEN O'RING GRVS.	O'RING GRV. WIDTH	O'RING GRV. DIA.	
FM 05	FMN 05	5	12	1.14	11.5	12	5	2	9.86	9.7 x 1.3
FM 08	FMN 08	8	14	1.14	15.2	16	5.33	2	13.2	13 x 1.7
FM 10	FMN 10	10	19.4	1.32	18.0	19	5.63	2.44	15.7	15.5 x 2
FM 12	FMN 12	12	20	1.32	21.0	22	6	3.17	17.9	17.5 x 2.5
FM 16	FMN 16	16	22	1.32	24.9	26	8	3.17	21.9	21.5 x 2.5
FM 20	FMN 20	20	28	1.63	30.3	32	10	3.17	27.9	27.5 x 2.5
FM 25	FMN 25	25	40	1.90	37.5	40	12.5	3.17	35.9	35.5 x 2.5
FM 30	FMN 30	30	48	1.90	44.5	47	15	3.17	42.7	42.52 x 2.62
FM 40	FMN 40	40	56	2.20	59.0	62	20	4.1	56.3	56 x 3.5
FM 50	FMN 50	50	72	2.70	72.0	75	25	4.1	69.2	69 x 3.5
FM 60	FMN 60	60	95	3.20	86.4	90	30	7.1	81.7	81 x 5
FM 80	FMN 80	80	125	4.17	116.1	120	40	7.1	111.7	111 x 5

The data and specifications in this publication have been carefully compiled and are believed to be accurate and correct. However, it is the responsibility of the user to determine and ensure the suitability of Pacific Bearing® products for a specific application. Pacific Bearing's only obligation will be to repair or replace without charge, any defective components if returned promptly. No liability is assumed beyond such replacement. *Consult www.pacific-bearing.com for the latest technical updates.



FM & FMN LINEAR BEARINGS

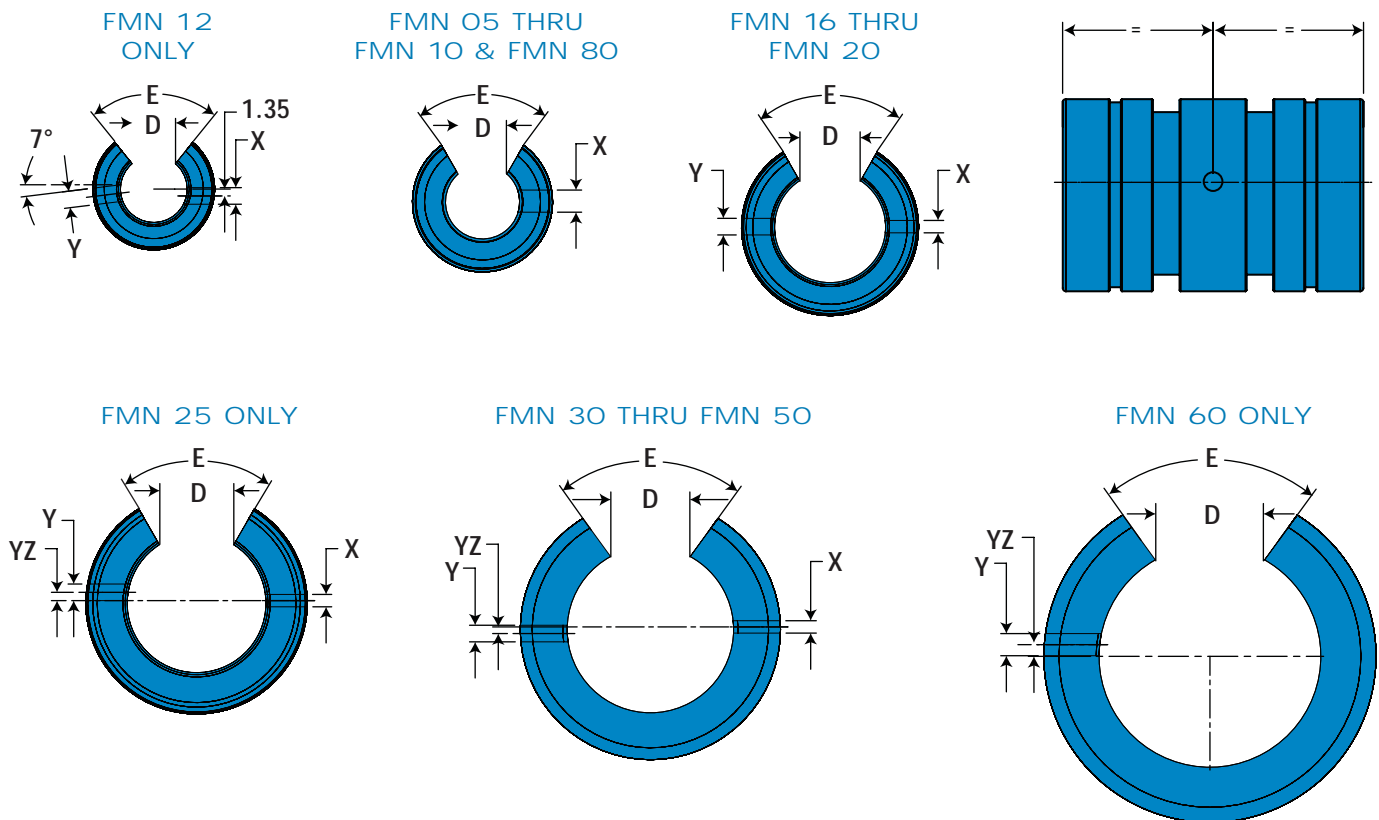

Self-lubricating Bearings

OPEN DIMENSIONAL INFORMATION

PART NO.	NOMINAL SIZE	D SLOT WIDE MIN.	E SLOT ANGLE	X RET. HOLE DIA.	Y RET. HOLE DIA.	YZ RET. HOLE LOCATE	BEARING WT.
							(kg.)
FMN 05	5	3.2	60	2.2	N / A	N / A	0.0034
FMN 08	8	5.1	60	3.0	N / A	N / A	0.0077
FMN 10	10	6.4	60	3.0	N / A	N / A	0.0119
FMN 12	12	7.6	78	3.0	3.0	7.0	0.0156
FMN 16	16	10.4	78	2.2	3.0	0	0.0213
FMN 20	20	10.8	60	2.2	3.0	0	0.0439
FMN 25	25	13.2	60	3.0	3.0	1.5	0.0893
FMN 30	30	14.2	72	3.0	3.0	2.0	0.1460
FMN 40	40	19.5	72	3.0	3.0	1.5	0.2948
FMN 50	50	24.0	72	3.0	5.0	2.5	0.5202
FMN 60	60	29.6	72	N / A	6.0	0	0.9199
FMN 80	80	39.0	72	N / A	8.0	0	2.2269

LOAD & SPEED DATA

PART NO.	EFFECTIVE SURFACE AREA (sq. in.)	MAX. STATIC LOAD FRELON		EFFECTIVE SURFACE AREA (mm ²)	MAX. STATIC LOAD FRELON	
		GOLD (lbs.)	J (lbs.)		GOLD (N)	J (N)
FMN 05	1.1	232	116	110	2276	1138
FMN 08	2	420	210	200	4120	2060
FMN 10	2.9	610	305	290	5984	2992
FMN 12	3.8	806	403	380	7907	3953
FMN 16	5.8	1210	605	580	11870	5935
FMN 20	9	1890	945	900	18541	9270
FMN 25	14.5	3046	1523	1450	29881	14941
FMN 30	20.4	4284	2142	2040	42026	21013
FMN 40	32	6720	3360	3200	65923	32962
FMN 50	50	10500	5250	5000	103005	51503
FMN 60	75	15750	7875	7500	154508	77254
FMN 80	132	27720	13860	13200	271933	135967
		MAX. PV (m/min. * kg/sq. cm) FrelonGold = 430 PV FrelonJ = 215 PV		MAX. PV (m/s. * N/mm ²) FrelonGold = 0.70 PV FrelonJ = 0.35 PV		
		MAX. Speed Running Dry (m/min.) FrelonGold = 91.4 FrelonJ = 42.6		MAX. Speed Running Dry (m/s.) FrelonGold = 1.52 FrelonJ = 0.71		
		MAX. Speed Running with Lubrication (m/min.) FrelonGold = 251.5 FrelonJ = 122		MAX. Speed Running with Lubrication (m/s.) FrelonGold = 4.19 FrelonJ = 2.03		

Pillow Block Information.....	20-21
Thin Wall Bearings.....	22-23
Sleeve Bearings	156-157
Die Set Bushings	24
Flange Mounted Bearings	25-27

The data and specifications in this publication have been carefully compiled and are believed to be accurate and correct. However, it is the responsibility of the user to determine and ensure the suitability of Pacific Bearing® products for a specific application. Pacific Bearing's only obligation will be to repair or replace without charge, any defective components if returned promptly. No liability is assumed beyond such replacement. *Consult www.pacific-bearing.com for the latest technical updates.

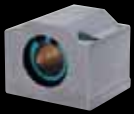

PM CLOSED PILLOW BLOCKS

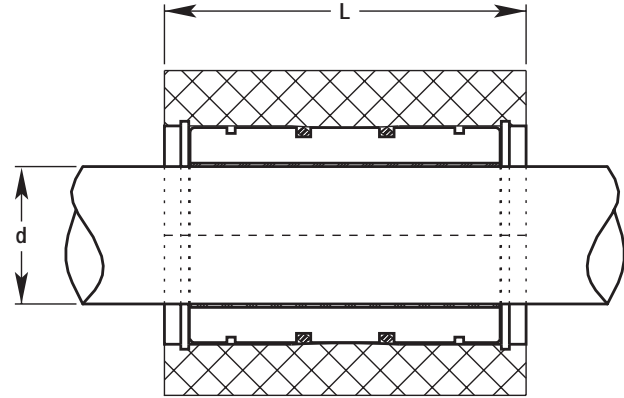
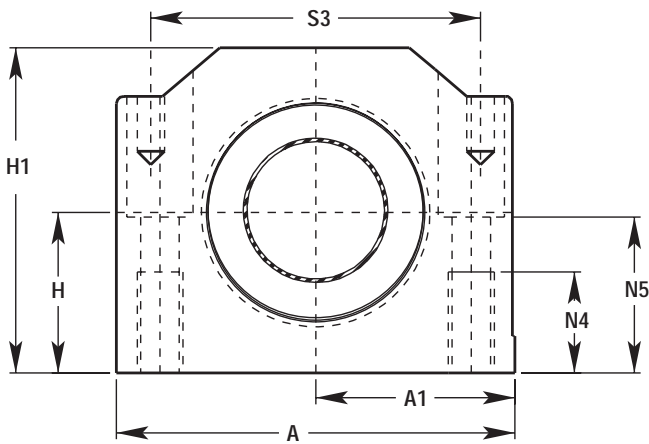
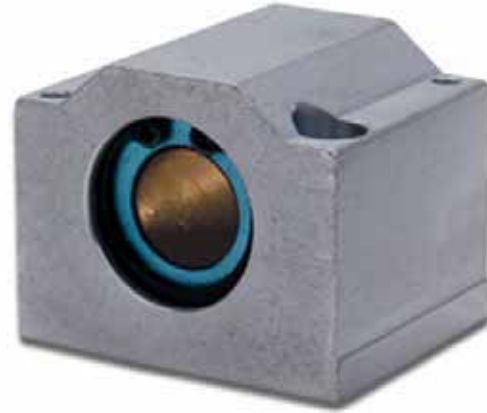
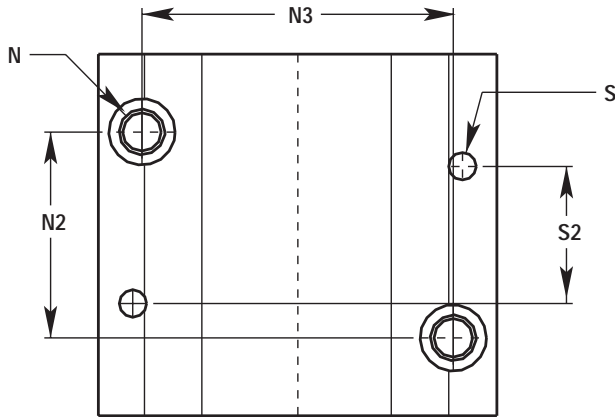

Pillow Blocks

CLOSED PILLOW BLOCKS

PART NO. CLOSED		d NOM. I.D.	H CENTERLINE	H1	A	A1	L	N	N2	N3	N4	N5	S	S2	S3	MAX. STATIC LOAD (kg.) FRELON		MAX. STATIC LOAD (N) FRELON		ASSEM. WT.
PRECISION	COMPEN.	MIN.	.015	HEIGHT	WIDTH	.013	LENGTH	BOLT								GOLD	J	GOLD	J	(kg.)
PM 08	PM 08 C	8	15	28	35	17.5	32	M4 x 0.7	20.15	25.15	9	14.5	N / A	N / A	N / A	420	210	4120	206	0.069
PM 10	PM 10 C	10	16	31.5	40	20	36	M5 x 0.8	20.15	29.15	11	15	4	29	31	610	305	5984	2992	0.095
PM 12	PM 12 C	12	18	35	43	21.5	39	M5 x 0.8	23.15	32.15	11	16.5	4	32	34	806	403	7907	3953	0.118
PM 16	PM 16 C	16	22	42	53	26.5	43	M6 x 1.0	26.15	40.15	13	21	4	35	42	1210	605	11870	5935	0.200
PM 20	PM 20 C	20	25	50	60	30	54	M8 x 1.25	32.15	45.15	18	24	5	45	50	1890	945	18541	9270	0.329
PM 25	PM 25 C	25	30	60	78	39	67	M10 x 1.5	40.15	60.15	22	29	6	20	64	3046	1523	29881	14941	0.655
PM 30	PM 30 C	30	35	71	87	43.5	79	M10 x 1.5	45.15	68.15	22	34	6	30	72	4284	2142	42026	21013	1.020
PM 40	PM 40 C	40	45	91	108	54	91	M12 x 1.75	58.15	86.15	26	44	8	35	90	6720	3360	65923	32962	1.846
PM 50	PM 50 C	50	50	105	132	66	113	M16 x 2.0	50.20	108.20	34	49	10	42	108	10500	5250	103005	51503	3.169

- NOTES:** (1) Standard pillow block assembly includes self-aligning housing and precision bearing.
 (2) All standard metric pillow blocks use standard "FM" series bearings found on page 18.
 (3) Straight bore pillow block assembly includes standard O.D. "FM" series bearing in straight bore housing.

The data and specifications in this publication have been carefully compiled and are believed to be accurate and correct. However, it is the responsibility of the user to determine and ensure the suitability of Pacific Bearing® products for a specific application. Pacific Bearing's only obligation will be to repair or replace without charge, any defective components if returned promptly. No liability is assumed beyond such replacement. *Consult www.pacific-bearing.com for the latest technical updates.

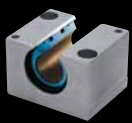

PMN OPEN PILLOW BLOCKS

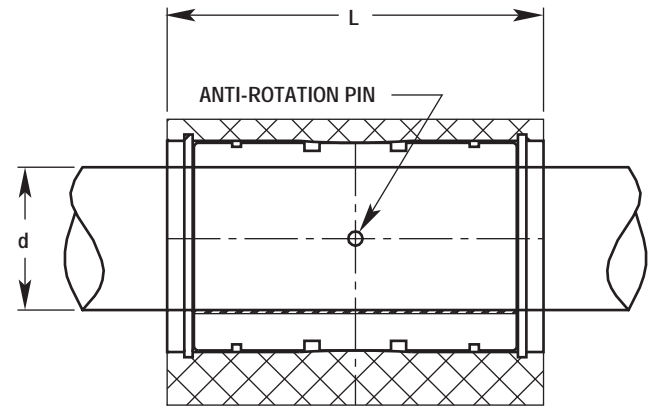
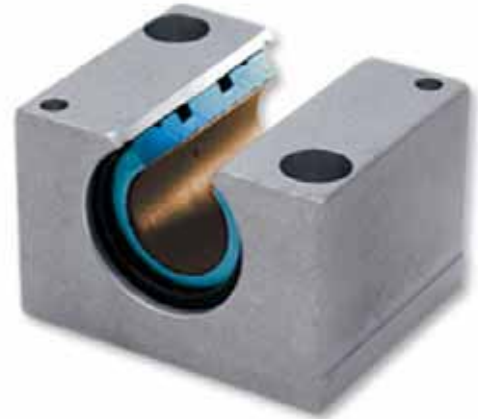
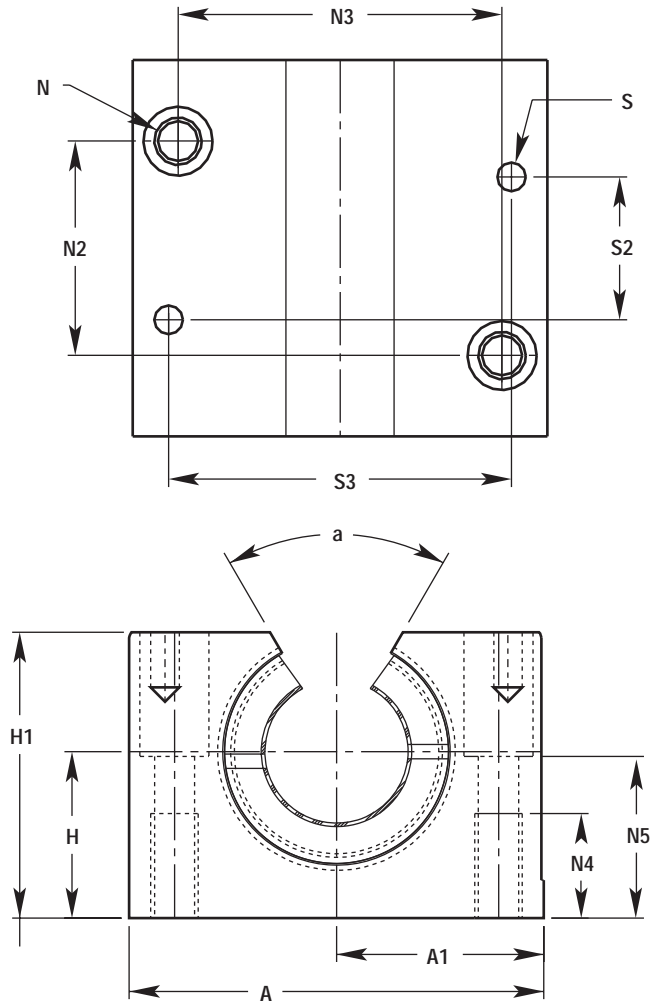

Pillow Blocks

OPEN PILLOW BLOCKS

PART NO. CLOSED		d NOM. I.D.	H CENTERLINE	H1	A	A1 CENTERLINE	L	N	N2	N3	N4	N5	S	S2	S3	a	MAX. STATIC LOAD (kg.) FRELON		MAX. STATIC LOAD (N) FRELON		ASSEM. WT.
PRECISION	COMPEN.	MIN.	.015	HEIGHT	WIDTH	.013	LENGTH	BOLT									GOLD	J	GOLD	J	(kg.)
PMN 12	PMN 12C	12	18	28	43	21.5	39	M5 x 0.8	23.15	32.15	11	16.5	4	32	34	66	806	403	7907	3953	0.096
PMN 16	PMN 16C	16	22	35	53	26.5	43	M6 x 1.0	26.15	40.15	13	21	4	35	42	68	1210	605	11870	5935	0.162
PMN 20	PMN 20C	20	25	42	60	30	54	M8 x 1.25	32.15	45.15	18	24	5	45	50	60	1890	945	18541	9270	0.267
PMN 25	PMN 25C	25	30	51	78	39	67	M10 x 1.5	40.15	60.15	22	29	6	20	64	60	3046	1523	29881	14941	0.536
PMN 30	PMN 30C	30	35	60	87	43.5	79	M10 x 1.5	45.15	68.15		34	6	30	72	60	4284	2142	42026	21013	0.831
PMN 40	PMN 40C	40	45	77	108	54	91	M12 x 1.75	58.15	86.15	26	44	8	35	90	60	6720	3360	65923	32962	1.499
PMN 50	PMN 50C	50	50	88	132	66	113	M16 x 2.0	50.20	108.20	34	49	10	42	108	60	10500	5250	103005	51503	2.539

NOTES: (1) Standard pillow block assembly includes self-aligning housing and precision bearing.
 (2) All standard metric pillow blocks use standard "FM" series bearings found on page 18.

The data and specifications in this publication have been carefully compiled and are believed to be accurate and correct. However, it is the responsibility of the user to determine and ensure the suitability of Pacific Bearing® products for a specific application. Pacific Bearing's only obligation will be to repair or replace without charge, any defective components if returned promptly. No liability is assumed beyond such replacement. *Consult www.pacific-bearing.com for the latest technical updates.



FMT COMPACT THIN WALL BEARINGS

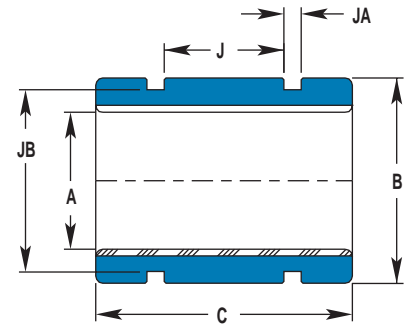
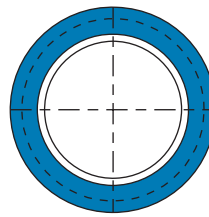
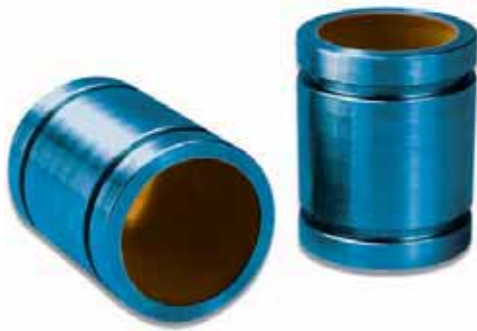

BASIC DIMENSIONAL INFORMATION

PRECISION I.D. SERIES Similar to preloaded ball bearing				COMPENSATED I.D. SERIES Similar to standard ball bearing			B O.D. (h7)		C LENGTH (h13)		CONCENTRIC	BEARING WEIGHT
PART NO.	NOMINAL SIZE	A BEARING I.D. (F8)		PART NO.	A BEARING I.D.							
CLOSED	(mm)	MIN.	MAX.	CLOSED	MIN.	MAX.	MIN.	MAX.	MIN.	MAX.	MAX. (mm)	(kg.)
FMT 06	6	6.010	6.028	FMTC 06	6.060	6.078	11.982	12	21.746	22	0.0254	0.0057
FMT 08	8	8.013	8.035	FMTC 08	8.063	8.085	14.982	15	23.746	24	0.0254	0.0071
FMT 10	10	10.013	10.035	FMTC 10	10.063	10.085	16.982	17	25.746	26	0.0254	0.0085
FMT 12	12	12.016	12.043	FMTC 12	12.066	12.093	18.979	19	27.746	28	0.0254	0.0113
FMT 14	14	14.016	14.043	FMTC 14	14.066	14.093	20.979	21	27.746	28	0.0254	0.0128
FMT 16	16	16.016	16.043	FMTC 16	16.066	16.093	23.979	24	29.746	30	0.0254	0.0184
FMT 20	20	20.020	20.053	FMTC 20	20.096	20.129	27.979	28	29.746	30	0.0254	0.0227
FMT 25	25	25.020	25.053	FMTC 25	25.096	25.129	34.975	35	39.746	40	0.0254	0.0439
FMT 30	30	30.020	30.053	FMTC 30	30.090	30.129	39.975	40	49.746	50	0.0254	0.0652
FMT 40	40	40.025	40.064	FMTC 40	40.127	40.166	51.970	52	59.746	60	0.0254	0.1233
FMT 50	50	50.025	50.064	FMTC 50	50.127	50.166	61.970	62	69.746	70	0.0254	0.1772

MOUNTING DIMENSIONS

PART NO.		NOMINAL SIZE	J BETWEEN O-RING GRVS.	JA O-RING GRV. WIDTH	JB O-RING GRV. DIA.	METRIC O-RING PART NO.
PRECISION	COMPENSATED					
FMT 06	FMTC 06	6	N / A	N / A	N / A	N / A
FMT 08	FMTC 08	8	10.0	2.000	12.200	12 x 1.7
FMT 10	FMTC 10	10	12.0	2.000	14.400	14 x 1.6
FMT 12	FMTC 12	12	14.0	2.000	16.600	16 x 1.5
FMT 14	FMTC 14	14	14.0	2.000	18.500	18 x 1.5
FMT 16	FMTC 16	16	14.0	2.000	21.300	21.1 x 1.6
FMT 20	FMTC 20	20	14.0	2.000	25.500	25 x 1.5
FMT 25	FMTC 25	25	22.0	3.200	30.900	30.5 x 2.5
FMT 30	FMTC 30	30	30.0	3.200	35.900	35.5 x 2.5
FMT 40	FMTC 40	40	40.0	4.100	46.200	46 x 3.5
FMT 50	FMTC 50	50	50.0	4.100	56.300	26 x 3.5

LOAD & SPEED DATA

PART NO.	EFFECTIVE SURFACE AREA (sq. cm.)	MAX. STATIC LOAD FRELON		EFFECTIVE SURFACE AREA (mm ²)	MAX. STATIC LOAD FRELON	
		GOLD (lbs.)	J (lbs.)		GOLD (N)	J (N)
FMT 06	1.3	278	139	130	2727	1364
FMT 08	1.9	404	202	190	3963	1982
FMT 10	2.6	546	273	260	5356	2678
FMT 12	3.4	706	353	340	6926	3463
FMT 14	3.9	824	412	390	8083	4042
FMT 16	4.8	1008	504	480	9888	4944
FMT 20	6.0	1260	630	600	12361	6180
FMT 25	10.0	2100	1050	1000	20601	10301
FMT 30	15.0	3150	1575	1500	30902	15451
FMT 40	24.0	5040	2520	2400	49442	24721
FMT 50	35.0	7350	3675	3500	72104	36052
	MAX. PV (m/min. * kg/sq. cm) FrelonGold = 430 PV FrelonJ = 215 PV			MAX. PV (m/s. * N/mm²) FrelonGold = 0.70 PV FrelonJ = 0.35 PV		
	MAX. Speed Running Dry (m/min.) FrelonGold = 91.4 FrelonJ = 42.6			MAX. Speed Running Dry (m/s.) FrelonGold = 1.52 FrelonJ = 0.71		
	MAX. Speed Running with Lubrication (m/min.) FrelonGold = 251.5 FrelonJ = 122			MAX. Speed Running with Lubrication (m/s.) FrelonGold = 4.19 FrelonJ = 2.03		

FrelonGOLD® and FrelonJ® are registered trademarks of Pacific Bearing.

The data and specifications in this publication have been carefully compiled and are believed to be accurate and correct. However, it is the responsibility of the user to determine and ensure the suitability of Pacific Bearing® products for a specific application. Pacific Bearing's only obligation will be to repair or replace without charge, any defective components if returned promptly. No liability is assumed beyond such replacement. *Consult www.pacific-bearing.com for the latest technical updates.



Simplicity® Self-lubricating Bearings

Compact Thin Wall Bearings - ISO Metric

Linear Motion Systems

FG COMPACT THIN WALL BEARINGS

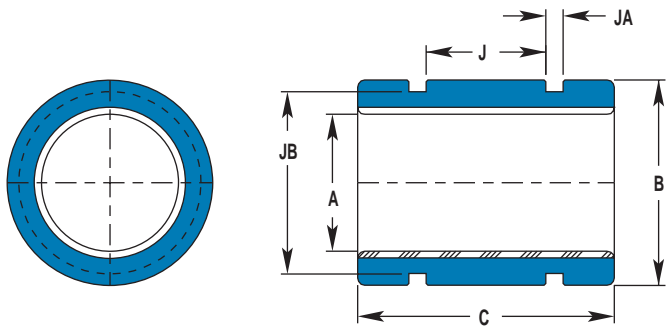

BASIC DIMENSIONAL INFORMATION

PRECISION I.D. SERIES Similar to preloaded ball bearing				COMPENSATED I.D. SERIES Similar to standard ball bearing			B O.D. (h7)		C LENGTH (h13)		CONCENTRIC MAX. mm	BEARING WEIGHT (kg.)
PART NO.	NOMINAL SIZE (mm)	A BEARING I.D. (F8) MIN. MAX.		PART NO.	A BEARING I.D. MIN. MAX.							
FG 06	6	6.010	6.028	FGC 06	6.060	6.078	11.98	12	17.8	18	0.0254	0.004
FG 08	8	8.013	8.035	FGC 08	8.063	8.085	14.98	15	19.8	20	0.0254	0.006
FG 10	10	10.013	10.035	FGC 10	10.063	10.085	16.98	17	21.8	22	0.0254	0.008
FG 12	12	12.016	12.043	FGC 12	12.066	12.093	21.98	22	26.8	27	0.0254	0.018
FG 15	15	15.016	15.043	FGC 15	15.066	15.093	24.98	25	27.8	28	0.0254	0.022
FG 16	16	16.016	16.043	FGC 16	16.066	16.093	25.98	26	29.8	30	0.0254	0.025
FG 18	18	18.020	18.053	FGC 18	18.096	18.129	27.98	28	29.8	30	0.0254	0.027
FG 20	20	20.020	20.053	FGC 20	20.096	20.129	31.98	32	34.8	35	0.0254	0.044
FG 25	25	25.020	25.053	FGC 25	25.096	25.129	39.98	40	44.8	45	0.0254	0.091
FG 30	30	30.020	30.053	FGC 30	30.096	30.129	44.98	45	53.8	54	0.0254	0.127
FG 35	35	35.025	35.064	FGC 35	35.127	35.166	51.98	52	61.7	62	0.0254	0.189
FG 40	40	40.025	40.064	FGC 40	40.127	40.166	59.98	60	71.7	72	0.0254	0.301
FG 50	50	50.025	50.064	FGC 50	50.127	50.166	74.98	75	89.7	90	0.0254	0.596

MOUNTING DIMENSIONS

PART NO.		NOMINAL SIZE	J BETWEEN O-RING GRVS.	JA O-RING GRV. WIDTH	JB O-RING GRV. DIA.	METRIC O-RING PART NO.
PRECISION	COMPENSATED					
FG 06	FGC 06	6	N / A	N / A	N / A	N / A
FG 08	FGC 08	8	8.0	2.032	12.201	12 x 1.7
FG 10	FGC 10	10	8.3	2.032	14.415	14 x 1.6
FG 12	FGC 12	12	12.0	3.175	17.907	17.5 x 2.5
FG 15	FGC 15	15	12.7	3.175	20.671	20 x 2.65
FG 16	FGC 16	16	12.7	3.175	21.882	21.5 x 2.5
FG 18	FGC 08	18	14.0	3.175	23.885	23.5 x 2.5
FG 20	FGC 20	20	17.0	3.175	27.864	27.5 x 2.5
FG 25	FGC 25	25	24.0	3.175	35.865	35.5 x 2.5
FG 30	FGC 30	30	30.0	3.175	40.895	40 x 2.5
FG 35	FGC 35	35	36.0	4.115	46.200	46 x 3.5
FG 40	FGC 40	40	37.3	4.115	54.255	53 x 3.5
FG 50	FGC 50	50	50	4.115	69.215	69 x 3.5

LOAD & SPEED DATA

PART NO.	EFFECTIVE SURFACE AREA (sq. cm.)	MAX. STATIC LOAD FRELON		EFFECTIVE SURFACE AREA (mm ²)	MAX. STATIC LOAD FRELON	
		GOLD (lbs.)	J (lbs.)		GOLD (N)	J (N)
FG 06	1.1	226	113	110	2217	1109
FG 08	1.6	336	168	160	3296	1648
FG 10	2.2	462	231	220	4532	2266
FG 12	3.2	680	340	320	6671	3335
FG 15	4.2	882	441	420	8652	4326
FG 16	4.8	1008	504	480	9888	4944
FG 18	5.4	1134	567	540	11125	5562
FG 20	7.0	1470	735	700	14421	7210
FG 25	11.3	2362	1181	1130	23171	11586
FG 30	16.2	3402	1701	1620	33374	16687
FG 35	21.7	4558	2279	2170	44714	22357
FG 40	28.8	6048	3024	2880	59331	29665
FG 50	45.0	9450	4725	4500	92705	46352
	MAX. PV (m/min. * kg/sq. cm) FrelonGold = 430 PV FrelonJ = 215 PV		MAX. PV (m/s. * N/mm ²) FrelonGold = 0.70 PV FrelonJ = 0.35 PV			
	MAX. Speed Running Dry (m/min.) FrelonGold = 91.4 FrelonJ = 42.6		MAX. Speed Running Dry (m/s.) FrelonGold = 1.52 FrelonJ = 0.71			
	MAX. Speed Running with Lubrication (m/min.) FrelonGold = 251.5 FrelonJ = 122		MAX. Speed Running with Lubrication (m/s.) FrelonGold = 4.19 FrelonJ = 2.03			

FrelonGOLD® and FrelonJ® are registered trademarks of Pacific Bearing.

The data and specifications in this publication have been carefully compiled and are believed to be accurate and correct. However, it is the responsibility of the user to determine and ensure the suitability of Pacific Bearing® products for a specific application. Pacific Bearing's only obligation will be to repair or replace without charge, any defective components if returned promptly. No liability is assumed beyond such replacement. *Consult www.pacific-bearing.com for the latest technical updates.



Simplicity® Self-Lubricating Bearings

Die Set Bushings - ISO Metric

Linear Motion Systems

PACM DIE SET BUSHINGS

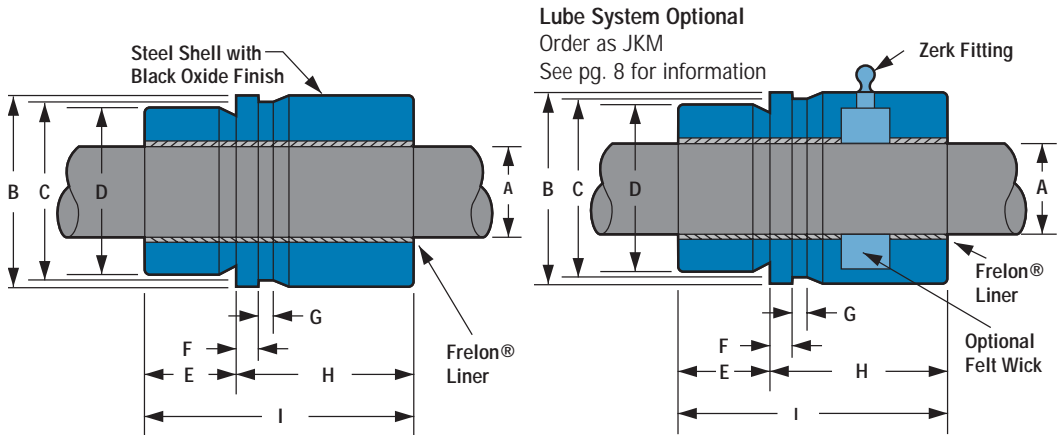

PART NO.	NOMINAL SIZE	A BEARING I.D.		PART NO.	A BEARING I.D.		B FLANGE & BARREL O.D. (H7)		C CLAMP DIA.	D PILOT O.D. (H7)		E PILOT LENGTH	F FLANGE LENGTH	G RECESS LENGTH	H HEAD LENGTH	I OVERALL LENGTH	EFFECTIVE SURFACE AREA (sq. cm)	MAX. STATIC LOAD (kg.) FRELON		BEARING WEIGHT (kg.)
		MIN.	MAX.		MIN.	MAX.	MIN.	MAX.		MIN.	MAX.							GOLD	J	
PACM 19	19	19.020	19.053	PACM 19 C	19.096	19.129	33.975	34	29	27.979	28	18	5	18	52	70	13.928	2925	1469	0.282
PACM 25	25	25.020	25.053	PACM 25 C	25.096	25.129	43.975	44	39	37.975	38	23		20	57	80	20.944	4398	2209	0.551
PACM 32	32	32.020	32.053	PACM 32 C	32.096	32.129	52.970	53	48	44.975	45	26		64	90	30.159	6333	3180	0.834	
PACM 40	40	40.025	40.064	PACM 40 C	40.127	40.166	62.970	63	58	53.970	54	30		70	100	41.888	8796	4417	1.229	
PACM 50	50	50.025	50.064	PACM 50 C	50.127	50.166	78.970	79	74	64.970	65	35		75	110	57.596	12095	6073	2.055	
PACM 63	63	63.030	63.076	PACM 63 C	63.182	63.228	91.965	92	87	80.970	81	48		82	130	85.765	10811	9044	2.984	
PACM 80	80	80.030	80.076	PACM 80 C	80.182	80.228	110.965	111	106	99.965	100	48	102	150	125.664	26389	13251	4.772		

NOTES: Formula used for effective surface area is $(\pi * ID * L)/3$
 Max static load is effective surface area times max load for FrelonGOLD®
 - 210 kgf/cm² is the rating for FrelonGOLD®
 - 105.45 kgf/cm² is the rating for FrelonJ®

NOTE: DIMENSION FOR CALCULATING BOLT CIRCLE

$$J = C + 15.8\text{mm}$$

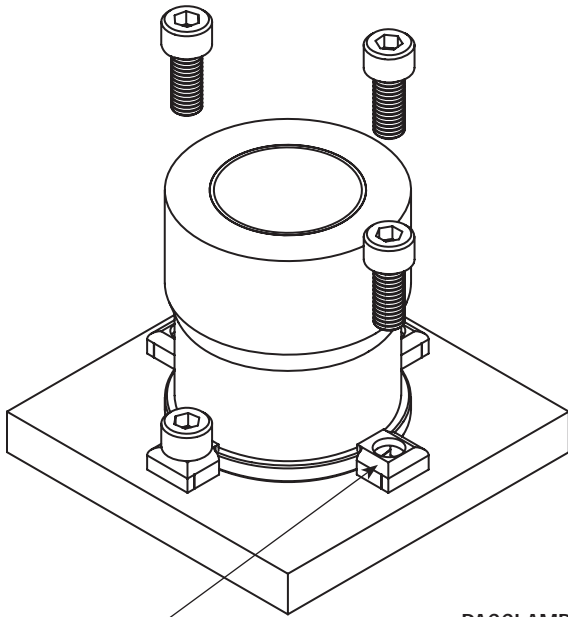
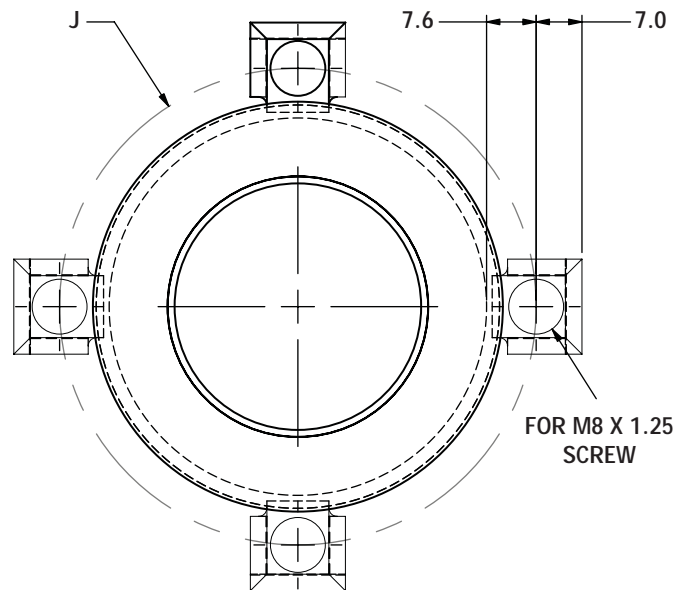

4 PAC CLAMPS ARE SHIPPED WITH EACH DIESET

EXTRAS CAN BE ORDERED USING PART #: PACCLAMP

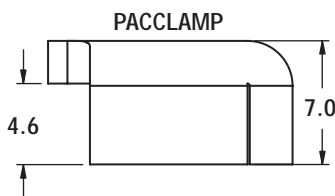

The data and specifications in this publication have been carefully compiled and are believed to be accurate and correct. However, it is the responsibility of the user to determine and ensure the suitability of Pacific Bearing® products for a specific application. Pacific Bearing's only obligation will be to repair or replace without charge, any defective components if returned promptly. No liability is assumed beyond such replacement. *Consult www.pacific-bearing.com for the latest technical updates.



SFPM FLANGE BEARINGS

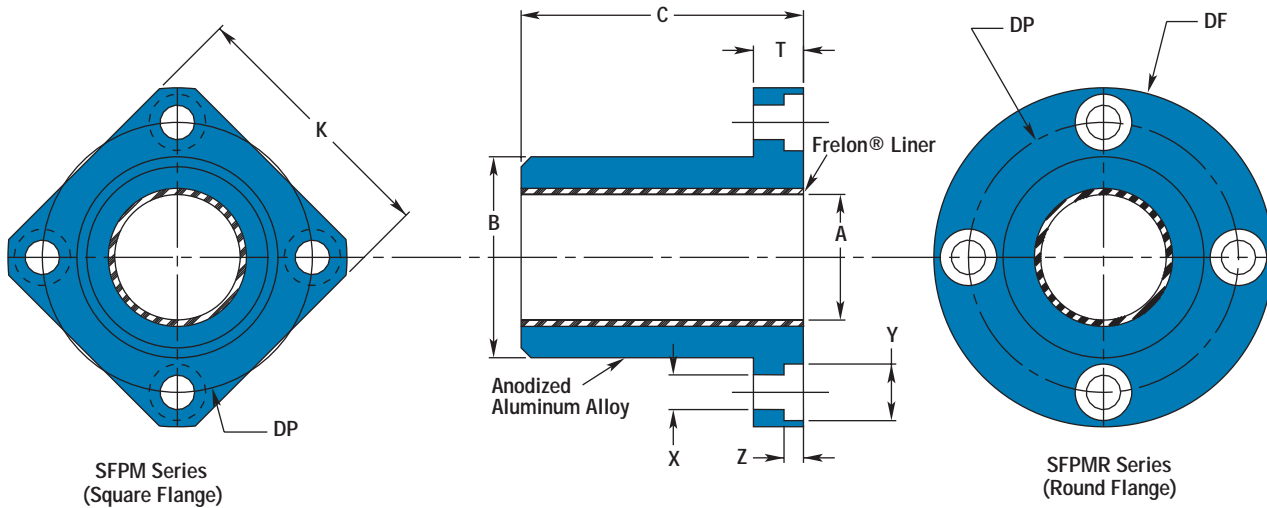

Flange Bearings

BASIC DIMENSIONAL INFORMATION

PRECISION I.D. SERIES Similar to preloaded ball bearing				COMPENSATED I.D. SERIES Similar to standard ball bearing				B		C		EFFECTIVE SURFACE AREA (sq. cm)	MAX. STATIC LOAD (kg.) FRELON		
PART NO.		NOMINAL SIZE (mm)	A BEARING I.D. (F8)		PART NO.		A BEARING I.D.		BODY O.D. (h7)		LENGTH (h13)		GOLD	J	
SQUARE	ROUND		MIN.	MAX.	SQUARE	ROUND	MIN.	MAX.	MIN.	MAX.	MIN.	MAX.			
SFPM 08	SFPMR 08	8	8.013	8.035	SFPM 08C	SFPMR 08C	8.063	8.085	15.982	16	24.8	25	2.094	440	221
SFPM 12	SFPMR 12	12	12.016	12.043	SFPM 12C	SFPMR 12C	12.066	12.093	21.979	22	31.8	32	4.021	844	424
SFPM 16	SFPMR 16	16	16.016	16.043	SFPM 16C	SFPMR 16C	16.066	16.093	25.979	26	35.8	36	6.032	1267	636
SFPM 20	SFPMR 20	20	20.020	20.053	SFPM 20C	SFPMR 20C	20.096	20.129	31.975	32	44.8	45	9.425	1979	994
SFPM 25	SFPMR 25	25	25.020	25.053	SFPM 25C	SFPMR 25C	25.096	25.129	39.975	40	57.7	58	15.184	3189	1601
SFPM 30	SFPMR 30	30	30.020	30.053	SFPM 30C	SFPMR 30C	30.096	30.129	46.975	47	67.7	68	21.363	4486	2253
SFPM 40	SFPMR 40	40	40.025	40.064	SFPM 40C	SFPMR 40C	40.127	40.166	61.970	62	79.7	80	33.510	7037	3534
SFPM 50	SFPMR 50	50	50.025	50.064	SFPM 50C	SFPMR 50C	50.127	50.166	74.970	75	99.7	100	52.360	10996	5521
SFPM 60	SFPMR 60	60	60.030	60.076	SFPM 60C	SFPMR 60C	60.182	60.228	89.965	90	124.6	125	78.540	16493	8282
SFPM 80	SFPMR 80	80	80.030	80.076	SFPM 80C	SFPMR 80C	80.182	80.228	119.965	120	164.6	165	138.230	29028	14576

NOTES: Formula used for effective surface area is $(\pi * ID * L)/3$
 Max static load is effective surface area times max load for FrelonGOLD®
 - 210 kgf/cm² is the rating for FrelonGOLD®
 - 105.45 kgf/cm² is the rating for FrelonJ®

MOUNTING DIMENSIONAL INFORMATION

PART NO.		K SQUARE	Df O.D.	T LENGTH	Dp BOLT CIRCLE	X HOLE	Y C'BORE DEPTH	Z C'BORE DEPTH	CLAMPING BOLT	CONCENTRICITY	SQUARENESS	SFPM WEIGHTS (kg.)	SFPMR WEIGHTS (kg.)	
SQUARE	ROUND	MAX.	MAX.	MAX.										
SFPM 08	SFPMR 08	25	32	8	24	3.5	6	3.1	M 3	0.012	0.012	0.018	0.022	
SFPM 12	SFPMR 12	32	42	9	32	4.5	7.5	4.1	M 4			0.037	0.046	
SFPM 16	SFPMR 16	35	46									36	0.047	0.058
SFPM 20	SFPMR 20	42	54	11	43	5.5	9	5.1	M 5	0.015	0.015	0.085	0.101	
SFPM 25	SFPMR 25	50	62									51	0.156	0.172
SFPM 30	SFPMR 30	60	76									62	0.257	0.293
SFPM 40	SFPMR 40	75	98	18	80	9.0	14	8.1	M 8	0.017	0.017	0.500	0.595	
SFPM 50	SFPMR 50	88	112									94	0.825	0.930
SFPM 60	SFPMR 60	106	134									112	1.506	1.697
SFPM 80	SFPMR 80	136	164	24	142	11.0	17	11.1	M 10	0.020	0.020	3.308	3.483	

The data and specifications in this publication have been carefully compiled and are believed to be accurate and correct. However, it is the responsibility of the user to determine and ensure the suitability of Pacific Bearing® products for a specific application. Pacific Bearing's only obligation will be to repair or replace without charge, any defective components if returned promptly. No liability is assumed beyond such replacement. *Consult www.pacific-bearing.com for the latest technical updates.



DFPM FLANGE BEARINGS

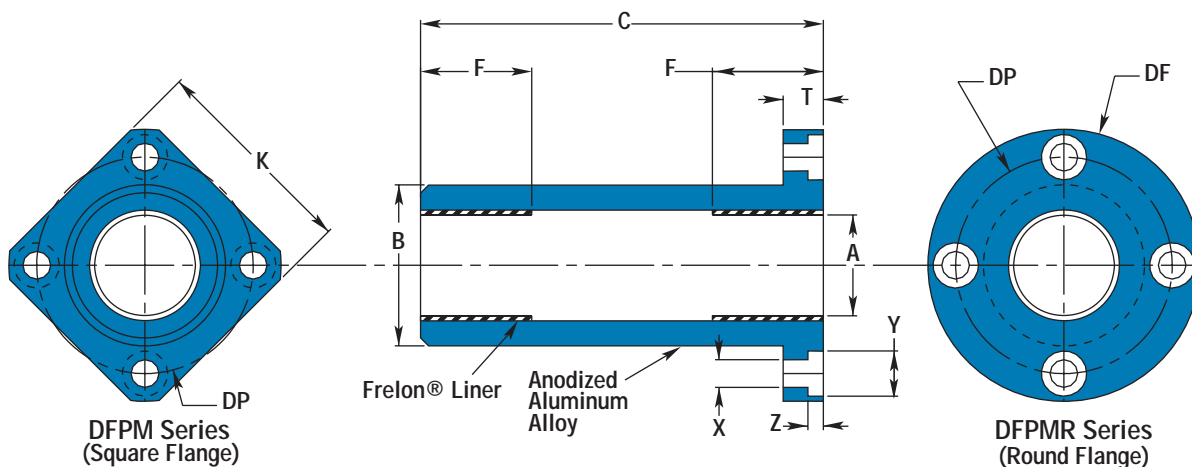

BASIC DIMENSIONAL INFORMATION

PRECISION I.D. SERIES Similar to preloaded ball bearing					COMPENSATED I.D. SERIES Similar to standard ball bearing					B BODY O.D. (h7)		C LENGTH		F LENGTH EACH END	EFFECTIVE SURFACE AREA (sq. cm)	MAX. STATIC LOAD (kg.) FRELON	
PART NO.		NOMINAL SIZE (mm)	A BEARING I.D. (F8)		PART NO.		A BEARING I.D.		MIN.							MAX.	MIN.
SQUARE	ROUND		MIN.	MAX.	SQUARE	ROUND	MIN.	MAX.									
DFPM 08	DFPMR 08	8	8.013	8.035	DFPM 08C	DFPMR 08C	8.063	8.085	15.982	16	44.7	45	12.1	2.027	426	214	
DFPM 12	DFPMR 12	12	12.016	12.043	DFPM 12C	DFPMR 12C	12.066	12.093	21.979	22	56.7	57	15.4	3.870	813	408	
DFPM 16	DFPMR 16	16	16.016	16.043	DFPM 16C	DFPMR 16C	16.066	16.093	25.979	26	69.7	70	20.4	6.836	1436	721	
DFPM 20	DFPMR 20	20	20.020	20.053	DFPM 20C	DFPMR 20C	20.096	20.129	31.975	32	79.7	80	22.1	9.257	1944	976	
DFPM 25	DFPMR 25	25	25.020	25.053	DFPM 25C	DFPMR 25C	25.096	25.129	39.975	40	111.6	112	33.1	17.331	3640	1828	
DFPM 30	DFPMR 30	30	30.020	30.053	DFPM 30C	DFPMR 30C	30.096	30.129	46.975	47	122.6	123	35	21.991	4618	2319	
DFPM 40	DFPMR 40	40	40.025	40.064	DFPM 40C	DFPMR 40C	40.127	40.166	61.970	62	150.6	151	44	36.861	7741	3887	
DFPM 50	DFPMR 50	50	50.025	50.064	DFPM 50C	DFPMR 50C	50.127	50.166	74.970	75	191.6	192	69.5	72.780	15284	7675	
DFPM 60	DFPMR 60	60	60.030	60.076	DFPM 60C	DFPMR 60C	60.182	60.228	89.965	90	208.6	209	73	91.735	19264	9673	

NOTES: Formula used for effective surface area is $(\pi * ID * L)/3$
 Max static load is effective surface area times max load for FrelonGOLD®
 - 210 kgf/cm² is the rating for FrelonGOLD®
 - 105.45 kgf/cm² is the rating for FrelonJ®
 Frelon pads in each end (F dimension)

MOUNTING DIMENSIONAL INFORMATION

PART NO.		K SQUARE	Df O.D.	T LENGTH	Dp BOLT CIRCLE	X HOLE	Y C'BORE DEPTH	Z C'BORE DEPTH	CLAMPING BOLT	CONCENTRICITY	SQUARENESS	DFPM WEIGHTS (kg.)	DFPMR WEIGHTS (kg.)
SQUARE	ROUND	MAX.	MAX.	MAX.									
DFPM 08	DFPMR 08	25	32	8	24	3.5	6	3.1	M 3	0.015	0.015	0.027	0.031
DFPM 12	DFPMR 12	32	42	9	32	4.5	7.5	4.1	M 4			0.055	0.064
DFPM 16	DFPMR 16	35	46		36							0.078	0.089
DFPM 20	DFPMR 20	42	54	11	43	5.5	9	5.1	M 5	0.017	0.017	0.133	0.149
DFPM 25	DFPMR 25	50	62		51							0.270	0.286
DFPM 30	DFPMR 30	60	76	14	62	6.6	11	6.1	M 6	0.020	0.020	0.413	0.450
DFPM 40	DFPMR 40	75	98		80							0.846	0.942
DFPM 50	DFPMR 50	88	112	18	94	9.0	14	8.1	M 8	0.025	0.025	1.450	1.556
DFPM 60	DFPMR 60	106	134		24							112	11.0

The data and specifications in this publication have been carefully compiled and are believed to be accurate and correct. However, it is the responsibility of the user to determine and ensure the suitability of Pacific Bearing® products for a specific application. Pacific Bearing's only obligation will be to repair or replace without charge, any defective components if returned promptly. No liability is assumed beyond such replacement. *Consult www.pacific-bearing.com for the latest technical updates.



CFPM FLANGE BEARINGS

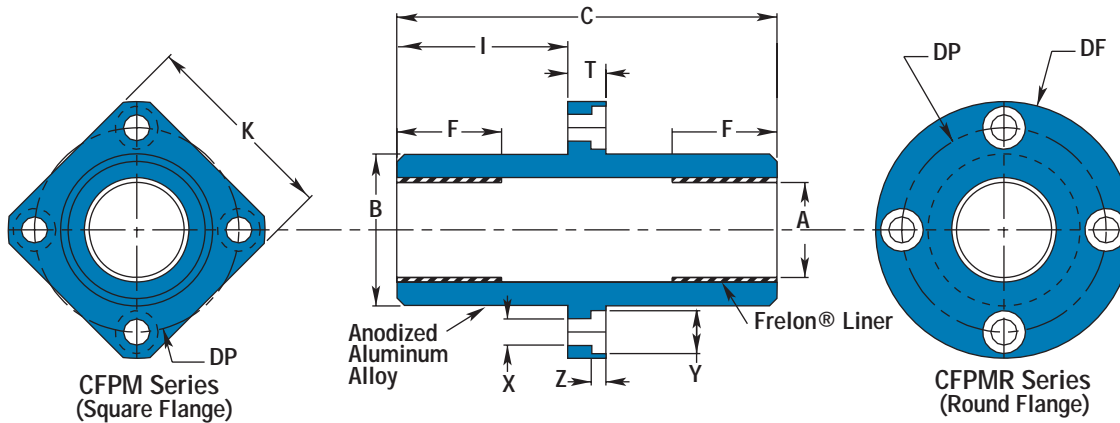

BASIC DIMENSIONAL INFORMATION

PRECISION I.D. SERIES Similar to preloaded ball bearing				COMPENSATED I.D. SERIES Similar to standard ball bearing				BODY O.D. (h7)		C LENGTH		I LENGTH TO FLNG.	F LENGTH EACH END	EFFECTIVE SURFACE AREA (sq. cm)	MAX. STATIC LOAD (kg.) FRELON		
PART NO.		NOMINAL SIZE (mm)	BEARING I.D. (F8)		PART NO.		BEARING I.D.								MIN.	MAX.	GOLD
SQUARE	ROUND		MIN.	MAX.	SQUARE	ROUND	MIN.	MAX.	MIN.	MAX.	MIN.	MAX.					
CFPM 08	CFPMR 08	8	8.013	8.035	CFPM 08C	CFPMR 08C	8.063	8.085	15.982	16	45.7	46.3	20.5	12.1	2.027	426	214
CFPM 12	CFPMR 12	12	12.016	12.043	CFPM 12C	CFPMR 12C	12.066	12.093	21.979	22	60.7	61.3	27.5	15.4	3.870	813	408
CFPM 16	CFPMR 16	16	16.016	16.043	CFPM 16C	CFPMR 16C	16.066	16.093	25.979	26		68.3	31	20.4	6.836	1436	721
CFPM 20	CFPMR 20	20	20.020	20.053	CFPM 20C	CFPMR 20C	20.096	20.129	31.975	32		79.7	80.3	36	22.1	9.257	1944
CFPM 25	CFPMR 25	25	25.020	25.053	CFPM 25C	CFPMR 25C	25.096	25.129	39.975	40	111.7	112.3	52	33.1	17.331	3640	1828
CFPM 30	CFPMR 30	30	30.020	30.053	CFPM 30C	CFPMR 30C	30.096	30.129	46.975	47	122.7	123.3	56.5	35	21.991	4618	2319
CFPM 40	CFPMR 40	40	40.025	40.064	CFPM 40C	CFPMR 40C	40.127	40.166	61.970	62	150.7	151.3	69	44	36.861	7741	3887
CFPM 50	CFPMR 50	50	50.025	50.064	CFPM 50C	CFPMR 50C	50.127	50.166	74.970	75	191.7	192.3	89.5	69.5	72.780	15284	7675
CFPM 60	CFPMR 60	60	60.030	60.076	CFPM 60C	CFPMR 60C	60.182	60.228	89.965	90	208.7	209.3	95.5	73	91.735	19264	9673

NOTES: Formula used for effective surface area is $(\pi * ID * L)/3$
 Max static load is effective surface area times max load for FrelonGOLD®
 - 210 kgf/cm² is the rating for FrelonGOLD®
 - 105.45 kgf/cm² is the rating for FrelonJ®
 Frelon pads in each end (F dimension)

MOUNTING DIMENSIONAL INFORMATION

PART NO.		K SQUARE	Df O.D.	T LENGTH	Dp BOLT CIRCLE	X HOLE	Y C'BORE DEPTH	Z C'BORE DEPTH	CLAMPING BOLT	CONCENTRICITY	SQUARENESS	CFPM WEIGHTS	CFPMR WEIGHTS
SQUARE	ROUND	MAX.	MAX.	MAX.								(kg.)	(kg.)
CFPM 08	CFPMR 08	25	32	8	24	3.5	6	3.1	M 3	0.015	0.015	0.027	0.031
CFPM 12	CFPMR 12	32	42	9	32	4.5	7.5	4.1	M 4			0.058	0.067
CFPM 16	CFPMR 16	35	46		36							0.077	0.088
CFPM 20	CFPMR 20	42	54	11	43	5.5	9	5.1	M 5	0.017	0.017	0.133	0.149
CFPM 25	CFPMR 25	50	62		51							0.270	0.286
CFPM 30	CFPMR 30	60	76	18	62	9.0	14	6.1	M 6			0.413	0.450
CFPM 40	CFPMR 40	75	98		80					0.846	0.942		
CFPM 50	CFPMR 50	88	112		94					1.450	1.556		
CFPM 60	CFPMR 60	106	134	24	112	11.0	17	11.1	M 10	0.025	0.025	2.329	2.519

The data and specifications in this publication have been carefully compiled and are believed to be accurate and correct. However, it is the responsibility of the user to determine and ensure the suitability of Pacific Bearing® products for a specific application. Pacific Bearing's only obligation will be to repair or replace without charge, any defective components if returned promptly. No liability is assumed beyond such replacement. *Consult www.pacific-bearing.com for the latest technical updates.



FJ LINEAR BEARINGS

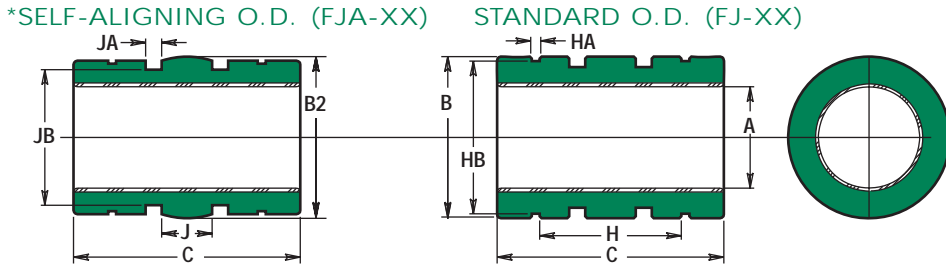

*Except for the O.D. bearings with the self-aligning feature have the same dimensions and tolerances as the standard bearing. There is a spherical crown on the O.D. to create the self-aligning feature. They are for use in a straight bore housing. Add an "A" to the part number per the example. More information on self-aligning bearings is on page 41-42.

BASIC DIMENSIONAL INFORMATION

PRECISION I.D. SERIES Similar to preloaded ball bearing				COMPENSATED I.D. SERIES Allows additional running clearance				B O.D.		FJA B2 O.D.		C LENGTH		CONCENTRIC	BEARING WEIGHT (kg.)	
PART NO.		NOMINAL SIZE (mm)	A BEARING I.D.		PART NO.		A BEARING I.D.									
CLOSED	OPEN		MIN.	MAX.	CLOSED	OPEN	MIN.	MAX.	MIN.	MAX.	MIN.	MAX.	MIN.	MAX.		
FJ06	N / A	6	6.010	6.028	FJC 06	FJCN 06	6.06	6.078	11.989	12	11.943	11.968	18.8	19	0.0254	0.004
FJH 08	FJHN 08	8	8.013	8.035	FJCH 08	FJCHN 08	8.063	8.085	14.989	15	14.943	14.968	16.8	17	0.0254	0.005
FJ 08	FJN 08	8	8.013	8.035	FJC 08	FJCN 08	8.063	8.085	14.989	15	14.943	14.968	23.8	24	0.0254	0.008
FJ 10	FJN 10	10	10.013	10.035	FJC 10	FJCN 10	10.063	10.086	18.987	19	18.936	18.969	28.8	29	0.0254	0.015
FJ 12	FJN 12	12	12.016	12.043	FJC 12	FJCN 12	12.066	12.093	20.987	21	20.942	20.968	29.8	30	0.0254	0.018
FJ 13	FJN 13	13	13.016	13.043	FJC 13	FJCN 13	13.066	13.093	22.987	23	22.944	22.969	31.8	32	0.0254	0.024
FJ 16	FJN 16	16	16.016	16.043	FJC 16	FJCN 16	16.066	16.093	27.988	28	27.943	27.968	36.8	37	0.0254	0.039
FJ 20	FJN 20	20	20.020	20.053	FJC 20	FJCN 20	20.096	20.129	31.984	32	31.941	31.966	41.8	42	0.0254	0.052
FJ 25	FJN 25	25	25.020	25.053	FJC 25	FJCN 25	25.096	25.129	39.984	40	39.942	39.967	58.7	59	0.0254	0.119
FJ 30	FJN 30	30	30.020	30.053	FJC 30	FJCN 30	30.096	30.129	44.984	45	44.940	44.966	63.7	64	0.0254	0.149
FJ 35	FJN 35	35	35.020	35.053	FJC 35	FJCN 35	35.100	35.136	51.981	52	51.940	51.966	69.7	70	0.0254	0.212
FJ 38	FJN 38	38	38.025	38.064	FJC 38	FJCN 38	38.127	38.166	56.981	57	56.940	56.966	75.7	76	0.0254	0.284
FJ 40	FJN 40	40	40.025	40.064	FJC 40	FJCN 40	40.127	40.166	59.981	60	59.939	59.964	79.7	80	0.0254	0.333
FJ 50	FJN 50	50	50.025	50.064	FJC 50	FJCN 50	50.127	50.166	79.981	80	79.939	79.964	99.7	100	0.0254	0.823
FJ 60	FJN 60	60	60.030	60.076	FJC 60	FJCN 60	60.182	60.228	89.978	90	89.939	89.964	109.7	110	0.0254	1.024
FJ 80	FJN 80	80	80.030	80.076	FJC 80	FJCN 80	80.182	80.228	119.978	120	119.939	119.964	139.6	140	0.0380	2.359
FJ 100	FJN 100	100	100.030	100.076	FJC 100	FJCN 100	100.182	100.228	149.975	150	149.936	149.962	174.6	175	0.0510	4.651
FJ 120	FJN 120	120	120.035	120.089	FJC 120	FJCN 120	120.190	120.236	179.975	180	179.936	179.962	199.6	200	0.0510	7.706
FJ 150	FJN 150	150	150.035	150.089	FJC 150	FJCN 150	150.190	150.236	209.971	210	209.934	209.959	239.6	240	0.0510	11.104

MOUNTING DIMENSIONAL INFORMATION

PART NO.		NOMINAL SIZE	H	HA	HB	RET. RING PART NO. (JIS B 2904)	J	JA	JB	METRIC O'RING PART NO.
CLOSED	OPEN	(mm)	BETWEEN RET. RINGS	RET. RING GRV. WIDTH	RET. RING GRV. DIA.		BETWEEN O'RING GRVS.	O'RING GRV. WIDTH	O'RING GRV. DIA.	
FJ06	N / A	6	11.3	1.15	11.5	STW - 12	4.293	2.032	9.859	9.7 x 1.3
FJH 08	FJHN08	8	9.2	1.15	14.3	STW - 15	2.540	2.362	12.243	12 x 1.7
FJ 08	FJN08	8	15.2	1.15	14.3	STW - 15	7.493	2.362	12.243	12 x 1.7
FJ 10	FJN 10	10	19.3	1.35	18.0	STW - 19	9.500	2.362	15.700	15.5 x 2
FJ 12	FJN 12	12	20.3	1.35	20.0	STW - 20	10.490	2.362	18.546	18 x 1.5
FJ 13	FJN 13	13	20.3	1.35	22.0	STW - 23	11.481	2.362	20.544	20 x 1.5
FJ 16	FJN 16	16	23.2	1.65	26.6	STW - 28	11.100	3.556	23.978	23.5 x 2.5
FJ 20	FJN 20	20	27.2	1.65	30.3	STW - 32	15.977	3.556	27.864	27.5 x 2.5
FJ 25	FJN 25	25	37.2	1.85	38.0	STW - 40	19.990	3.556	35.865	35.5 x 2.5
FJ 30	FJN 30	30	40.7	1.85	42.5	STW - 45	22.479	3.556	40.843	40 x 2.5
FJ 35	FJN 35	35	44.8	2.20	49.0	STW - 52	25.984	4.115	46.200	46 x 3.5
FJ 38	FJN 38	38	54.3	2.20	54.5	STW - 58	28.499	4.115	51.200	51 x 3.5
FJ 40	FJN 40	40	56.1	2.20	57.0	STW - 60	29.997	4.115	54.225	53 x 3.5
FJ 50	FJN 50	50	68.6	2.70	76.5	STW - 80	39.980	4.750	74.193	73 x 3.5
FJ 60	FJN 60	60	78.7	3.15	86.5	STW - 90	44.983	7.036	81.738	81 x 5
FJ 80	FJN 80	80	97.2	4.15	116.0	STW - 120	59.995	7.137	111.727	111 x 5
FJ 100	FJN 100	100	117.2	4.15	145.0	STW - 150	74.981	7.137	141.199	140 x 5.3
FJ 120	FJN 120	120	150.3	4.15	175.0	STW - 180	89.992	7.137	171.740	170 x 5
FJ 150	FJN 150	150	160.3	5.15	204.0	STW - 210	104.978	7.137	201.193	200 x 5.3

The data and specifications in this publication have been carefully compiled and are believed to be accurate and correct. However, it is the responsibility of the user to determine and ensure the suitability of Pacific Bearing® products for a specific application. Pacific Bearing's only obligation will be to repair or replace without charge, any defective components if returned promptly. No liability is assumed beyond such replacement. *Consult www.pacific-bearing.com for the latest technical updates.

Self-lubricating Bearings



FJ & FJN LINEAR BEARINGS

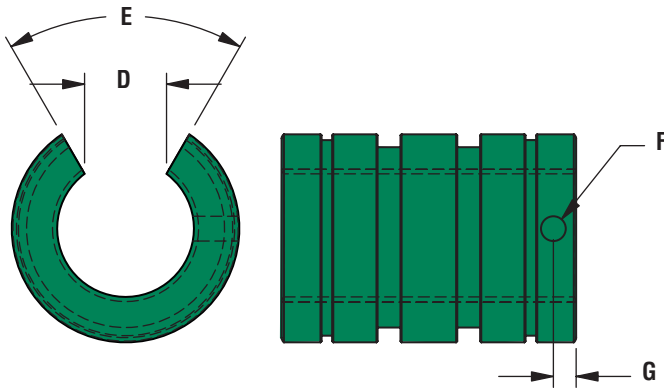

OPEN DIMENSIONAL INFORMATION

PART NO.		NOMINAL SIZE (mm)	D SLOT WIDTH MIN.	E SLOT ANGLE	F RET. HOLE DIA.	G RET. HOLE LOC.	BEARING WEIGHTS (kg.)				
CLOSED	OPEN										
FJHN 08	FJHCN 08	8	5.1	60	2.200	8.460	0.004				
FJN 08	FJCN 08						0.006				
FJN 10	FJCN 10	10	7.0	80	3.454	1.941	0.012				
FJN 12	FJCN 12	12	8.0				0.014				
FJN 13	FJCN 13	13	9.0				2.441	0.018			
FJN 16	FJCN 16	16	11.0				3.019	0.030			
FJN 20	FJCN 20	20					60	3.175	0.044		
FJN 25	FJCN 25	25	12.0				50	5.105	4.763	0.102	
FJN 30	FJCN 30	30	15.0	0.128							
FJN 35	FJCN 35	35	17.0	0.182							
FJN 38	FJCN 38	38	18.0	0.245							
FJN 40	FJCN 40	40	20.0	0.286							
FJN 50	FJCN 50	50	25.0	7.938	0.709						
FJN 60	FJCN 60	60	30.0	6.731	13.181	2.031					
FJN 80	FJCN 80	80	40.0								
FJN 100	FJCN 100	100	50.0							14.500	4.005
FJN 120	FJCN 120	120	85.0							16.103	5.994
FJN 150	FJCN 150	150	105.0				17.350	8.637			

LOAD & SPEED DATA

PART NO.	EFFECTIVE SURFACE AREA (sq.cm.)	MAX. STATIC LOAD FRELON		EFFECTIVE SURFACE AREA (mm ²)	MAX. STATIC LOAD FRELON	
		GOLD (kg.)	J (kg.)		GOLD (N)	J (N)
FJ 06	1.1	239	119.7	114	2348	1174
FJH 08	1.4	286	143	140	2805	1402
FJ 08	1.9	404	202	190	3962	1981
FJ 10	2.9	610	305	290	5982	2991
FJ 12	3.6	756	378	360	7413	3707
FJ 13	4.0	874	437	400	8570	4285
FJ 16	5.9	1244	622	590	12199	6099
FJ 20	8.4	1764	882	840	17298	8649
FJ 25	15.0	3098	1549	1500	30379	15189
FJ 30	19.0	4032	2016	1900	39538	19769
FJ 35	25.0	5146	2573	2500	50462	25231
FJ 38	29.0	6064	3032	2900	59464	29732
FJ 40	32.0	6720	3360	3200	65896	32948
FJ 50	50.0	10500	5250	5000	102963	51482
FJ 60	66.0	13860	6930	6600	135911	67956
FJ 80	112.0	23520	11760	11200	230637	115319
FJ 100	175.0	36750	18375	17500	360371	180185
FJ 120	240.0	50400	25200	24000	494222	247111
FJ 150	360.0	75600	37800	36000	741334	370667
		MAX. PV (m/min. * kg/sq. cm) FrelonGold = 430 PV FrelonJ = 215 PV		MAX. PV (m/s. * N/mm ²) FrelonGold = 0.70 PV FrelonJ = 0.35 PV		
		MAX. Speed Running Dry (m/min.) FrelonGold = 91.4 FrelonJ = 42.6		MAX. Speed Running Dry (m/s.) FrelonGold = 1.52 FrelonJ = 0.71		
		MAX. Speed Running with Lubrication (m/min.) FrelonGold = 251.5 FrelonJ = 122		MAX. Speed Running with Lubrication (m/s.) FrelonGold = 4.19 FrelonJ = 2.03		

Self-Lubricating Bearings

Flange Mounted Bearings 30-32
Retaining Ring Groove Dimension 28

The data and specifications in this publication have been carefully compiled and are believed to be accurate and correct. However, it is the responsibility of the user to determine and ensure the suitability of Pacific Bearing® products for a specific application. Pacific Bearing's only obligation will be to repair or replace without charge, any defective components if returned promptly. No liability is assumed beyond such replacement. *Consult www.pacific-bearing.com for the latest technical updates.



SFPJ FLANGE BEARINGS

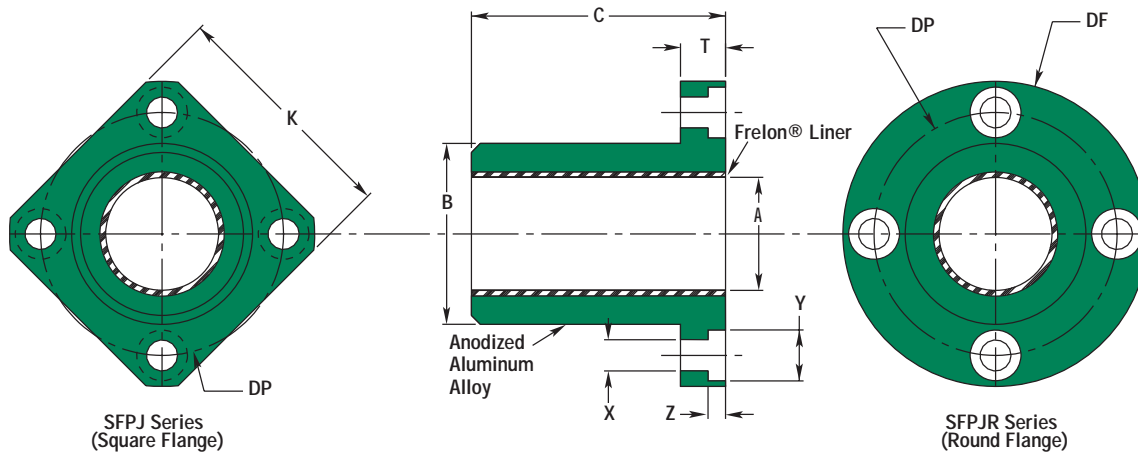

BASIC DIMENSIONAL INFORMATION

PRECISION I.D. SERIES Similar to preloaded ball bearing				COMPENSATED I.D. SERIES Similar to standard ball bearing				B BODY O.D. (h7)		C LENGTH (h13)		EFFECTIVE SURFACE AREA	MAX. STATIC LOAD (kg.) FRELON		
PART NO.		NOMINAL SIZE	A BEARING I.D. (F8)		PART NO.		A BEARING I.D.						MIN.	MAX.	(sq. cm)
SQUARE	ROUND	(mm)	MIN.	MAX.	SQUARE	ROUND	MIN.	MAX.	MIN.	MAX.					
SFPJ 06	SFPJR 06	6	6.010	6.028	SFPJ 06C	SFPJR 06C	6.060	6.078	11.982	12	18.8	19	1.194	251	126
SFPJ 08	SFPJR 08	8	8.013	8.035	SFPJ 08C	SFPJR 08C	8.063	8.085	14.982	15	23.8	24	2.011	422	212
SFPJ 10	SFPJR 10	10	10.013	10.035	SFPJ 10C	SFPJR 10C	10.063	10.085	18.979	19	28.8	29	3.037	638	320
SFPJ 12	SFPJR 12	12	12.016	12.043	SFPJ 12C	SFPJR 12C	12.066	12.093	20.979	21	29.8	30	3.770	792	398
SFPJ 13	SFPJR 13	13	13.016	13.043	SFPJ 13C	SFPJR 13C	13.066	13.093	22.979	23	31.8	32	4.356	915	459
SFPJ 16	SFPJR 16	16	16.016	16.043	SFPJ 16C	SFPJR 16C	16.066	16.093	27.979	28	36.8	37	6.199	1302	654
SFPJ 20	SFPJR 20	20	20.020	20.053	SFPJ 20C	SFPJR 20C	20.096	20.129	31.975	32	41.8	42	8.796	1847	928
SFPJ 25	SFPJR 25	25	25.020	25.053	SFPJ 25C	SFPJR 25C	25.096	25.129	39.975	40	58.7	59	15.446	3244	1629
SFPJ 30	SFPJR 30	30	30.020	30.053	SFPJ 30C	SFPJR 30C	30.096	30.129	44.975	45	63.7	64	20.106	4222	2120
SFPJ 35	SFPJR 35	35	35.020	35.053	SFPJ 35C	SFPJR 35C	35.096	35.129	51.970	52	69.7	70	25.656	5388	2705
SFPJ 40	SFPJR 40	40	40.025	40.064	SFPJ 40C	SFPJR 40C	40.127	40.166	59.970	60	79.7	80	33.510	7037	3534
SFPJ 50	SFPJR 50	50	50.025	50.064	SFPJ 50C	SFPJR 50C	50.127	50.166	79.965	80	99.7	100	52.360	10996	5521
SFPJ 60	SFPJR 60	60	60.030	60.076	SFPJ 60C	SFPJR 60C	60.182	60.228	89.965	90	109.6	110	69.115	14514	7288
SFPJ 80	SFPJR 80	80	80.030	80.076	SFPJ 80C	SFPJR 80C	80.182	80.228	119.965	120	139.6	140	117.286	24630	12368

NOTES: Formula used for effective surface area is $(\pi * ID * L)/3$
 Max static load is effective surface area times max load for FrelonGOLD®
 - 210 kgf/cm² is the rating for FrelonGOLD®
 - 105.45 kgf/cm² is the rating for FrelonJ®

MOUNTING DIMENSIONAL INFORMATION

PART NO.		K	Df	T	Dp	X	Y	Z	CLAMPING BOLT	CONCENTRICITY	SQUARENESS	SFPJ	SFPJR
SQUARE	ROUND	SQUARE MAX.	O.D. MAX.	LENGTH MAX.	BOLT CIRCLE	HOLE	C'BORE DIA.	C'BORE DEPTH				WEIGHTS (kg.)	WEIGHTS (kg.)
SFPJ 06	SFPJR 06	22	28	8	20	3.5	6	3.1	M 3	0.012	0.012	0.011	0.014
SFPJ 08	SFPJR 08	25	32	8	24	3.5	6	3.1	M 3	0.012	0.012	0.017	0.021
SFPJ 10	SFPJR 10	30	40	9	29	4.5	7.5	4.1	M 4	0.012	0.012	0.029	0.038
SFPJ 12	SFPJR 12	32	42	9	32	4.5	7.5	4.1	M 4	0.012	0.012	0.033	0.042
SFPJ 13	SFPJR 13	34	43	9	33	4.5	7.5	4.1	M 4	0.012	0.012	0.041	0.048
SFPJ 16	SFPJR 16	37	48	9	38	4.5	7.5	4.1	M 4	0.012	0.012	0.058	0.069
SFPJ 20	SFPJR 20	42	54	11	43	5.5	9	5.1	M 5	0.015	0.015	0.081	0.097
SFPJ 25	SFPJR 25	50	62	11	51	5.5	9	5.1	M 5	0.015	0.015	0.158	0.174
SFPJ 30	SFPJR 30	58	74	14	60	6.6	11	6.1	M 6	0.015	0.015	0.216	0.252
SFPJ 35	SFPJR 35	64	82	14	67	6.6	11	6.1	M 6	0.017	0.017	0.292	0.338
SFPJ 40	SFPJR 40	75	96	18	78	9.0	14	8.1	M 8	0.017	0.017	0.467	0.547
SFPJ 50	SFPJR 50	92	116	18	98	9.0	14	8.1	M 8	0.017	0.017	0.999	1.104
SFPJ 60	SFPJR 60	106	134	24	112	11.0	17	11.1	M 10	0.020	0.020	1.359	1.550
SFPJ 80	SFPJR 80	136	164	24	142	11.0	17	11.1	M 10	0.020	0.020	2.873	3.048

The data and specifications in this publication have been carefully compiled and are believed to be accurate and correct. However, it is the responsibility of the user to determine and ensure the suitability of Pacific Bearing® products for a specific application. Pacific Bearing's only obligation will be to repair or replace without charge, any defective components if returned promptly. No liability is assumed beyond such replacement. *Consult www.pacific-bearing.com for the latest technical updates.

Flange Bearings



DFPJ FLANGE BEARINGS

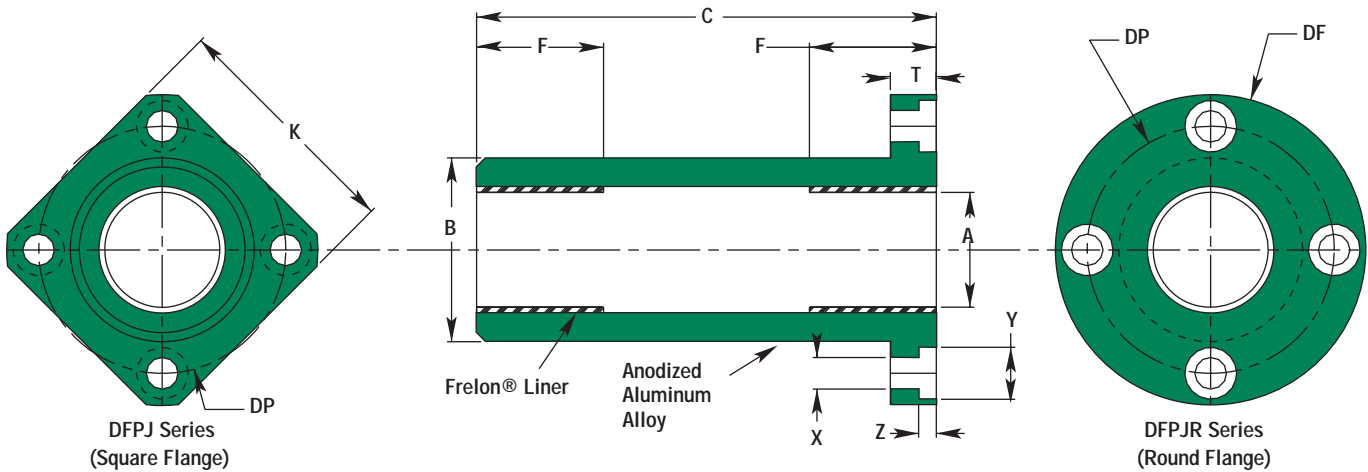

BASIC DIMENSIONAL INFORMATION

PRECISION I.D. SERIES Similar to preloaded ball bearing					COMPENSATED I.D. SERIES Similar to standard ball bearing				B BODY O.D. (h7)		C LENGTH		F LENGTH EACH END	EFFECTIVE SURFACE AREA	MAX. STATIC LOAD (kg.) FRELON	
PART NO.		NOMINAL SIZE	A BEARING I.D. (F8)		PART NO.		A BEARING I.D.								MIN.	MAX.
SQUARE	ROUND	(mm)	MIN.	MAX.	SQUARE	ROUND	MIN.	MAX.	MIN.	MAX.	MIN.	MAX.				
DFPJ 06	DFPJR 06	6	6.010	6.028	DFPJ 06C	DFPJR 06C	6.060	6.078	11.982	12	34.7	35	12	1.508	317	159
DFPJ 08	DFPJR 08	8	8.013	8.035	DFPJ 08C	DFPJR 08C	8.063	8.085	14.982	15	44.7	45	12	2.011	422	212
DFPJ 10	DFPJR 10	10	10.013	10.035	DFPJ 10C	DFPJR 10C	10.063	10.085	18.979	19	54.7	55	14	2.932	616	309
DFPJ 12	DFPJR 12	12	12.016	12.043	DFPJ 12C	DFPJR 12C	12.066	12.093	20.979	21	56.7	57	15	3.770	792	398
DFPJ 13	DFPJR 13	13	13.016	13.043	DFPJ 13C	DFPJR 13C	13.066	13.093	22.979	23	60.7	61	16	4.356	915	459
DFPJ 16	DFPJR 16	16	16.016	16.043	DFPJ 16C	DFPJR 16C	16.066	16.093	27.979	28	69.7	70	20	6.702	1407	707
DFPJ 20	DFPJR 20	20	20.020	20.053	DFPJ 20C	DFPJR 20C	20.096	20.129	31.975	32	79.7	80	22	9.215	1935	972
DFPJ 25	DFPJR 25	25	25.020	25.053	DFPJ 25C	DFPJR 25C	25.096	25.129	39.975	40	111.6	112	33	17.279	3629	1822
DFPJ 30	DFPJR 30	30	30.020	30.053	DFPJ 30C	DFPJR 30C	30.096	30.129	44.975	45	122.6	123	35	21.991	4618	2319
DFPJ 35	DFPJR 35	35	35.020	35.053	DFPJ 35C	DFPJR 35C	35.096	35.129	51.970	52	134.6	135	40	29.322	6158	3092
DFPJ 40	DFPJR 40	40	40.025	40.064	DFPJ 40C	DFPJR 40C	40.127	40.166	59.970	60	150.6	151	44	36.861	7741	3887
DFPJ 50	DFPJR 50	50	50.025	50.064	DFPJ 50C	DFPJR 50C	50.127	50.166	79.965	80	191.6	192	70	73.304	15394	7730
DFPJ 60	DFPJR 60	60	60.030	60.076	DFPJ 60C	DFPJR 60C	60.182	60.228	89.965	90	208.6	209	73	91.735	19264	9673

NOTES: Formula used for effective surface area is $(\pi * ID * L)/3$
 Max static load is effective surface area times max load for FrelonGOLD®
 - 210 kgf/cm² is the rating for FrelonGOLD®
 - 105.45 kgf/cm² is the rating for FrelonJ®
 Frelon pads in each end (F dimension)

MOUNTING DIMENSIONAL INFORMATION

PART NO.		K SQUARE	Df O.D.	T LENGTH	Dp BOLT CIRCLE	X HOLE	Y C'BORE DIA.	Z C'BORE DEPTH	CLAMPING BOLT	CONCENTRICITY	SQUARENESS	DFPJ WEIGHTS	DFPJR WEIGHTS
SQUARE	ROUND	MAX.	MAX.	MAX.								(kg.)	(kg.)
DFPJ 06	DFPJR 06	22	28	8	20	3.5	6	3.1	M 3	0.015	0.015	0.015	0.018
DFPJ 08	DFPJR 08	25	32		24							0.024	0.028
DFPJ 10	DFPJR 10	30	40		29							0.044	0.053
DFPJ 12	DFPJR 12	32	42	9	32	4.5	7.5	4.1	M 4	0.015	0.015	0.051	0.060
DFPJ 13	DFPJR 13	34	43		33							0.063	0.071
DFPJ 16	DFPJR 16	37	48		38							0.096	0.107
DFPJ 20	DFPJR 20	42	54	11	43	5.5	9	5.1	M 5	0.017	0.017	0.133	0.149
DFPJ 25	DFPJR 25	50	62		51							0.270	0.286
DFPJ 30	DFPJR 30	58	74		60							0.360	0.397
DFPJ 35	DFPJR 35	64	82	14	67	6.6	11	6.1	M 6	0.020	0.020	0.501	0.547
DFPJ 40	DFPJR 40	75	96		78							0.776	0.856
DFPJ 50	DFPJR 50	92	116		98							1.780	1.885
DFPJ 60	DFPJR 60	106	134	24	112	11.0	17	11.1	M 10	0.025	0.025	2.329	2.519

The data and specifications in this publication have been carefully compiled and are believed to be accurate and correct. However, it is the responsibility of the user to determine and ensure the suitability of Pacific Bearing® products for a specific application. Pacific Bearing's only obligation will be to repair or replace without charge, any defective components if returned promptly. No liability is assumed beyond such replacement. *Consult www.pacific-bearing.com for the latest technical updates.



CFPJ FLANGE BEARINGS

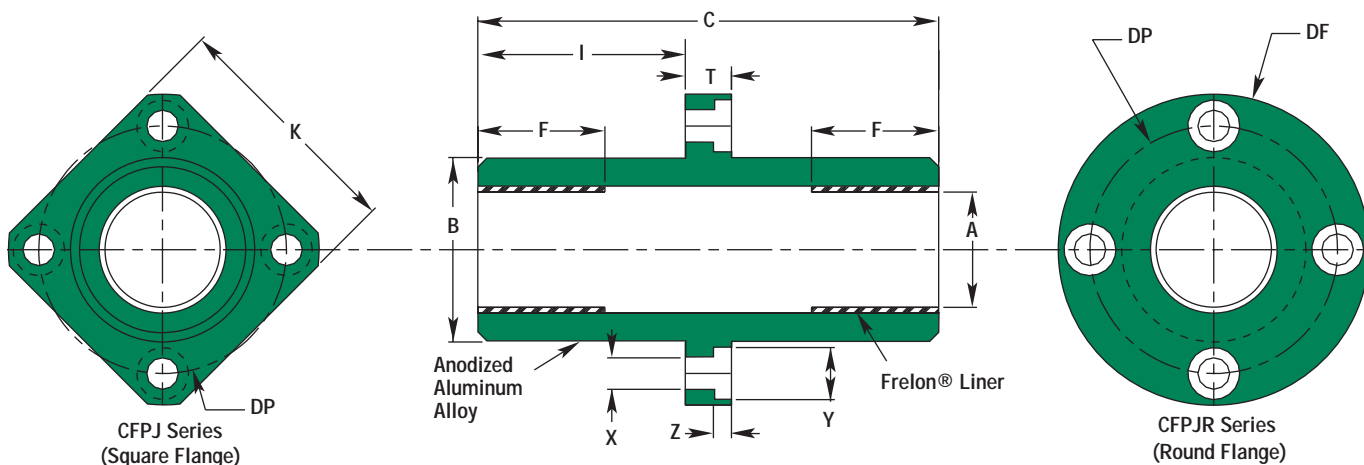

BASIC DIMENSIONAL INFORMATION

PRECISION I.D. SERIES Similar to preloaded ball bearing					COMPENSATED I.D. SERIES Similar to standard ball bearing				B BODY O.D. (h7)		C LENGTH		I LENGTH TO FLNG.	F LENGTH EACH END	EFFECTIVE SURFACE AREA (sq. cm)	MAX. STATIC LOAD (kg.) FRELON	
PART NO.		NOMINAL SIZE (mm)	A BEARING I.D. (F8)		PART NO.		A BEARING I.D.									MIN.	MAX.
CFPJ 06	CFPJR 06	6	6.010	6.028	CFPJ 06C	CFPJR 06C	6.060	6.078	11.982	12	34.7	35.3	15	12	1.508	317	159
CFPJ 08	CFPJR 08	8	8.013	8.035	CFPJ 08C	CFPJR 08C	8.063	8.085	14.982	15	44.7	45.3	20	12	2.011	422	212
CFPJ 10	CFPJR 10	10	10.013	10.035	CFPJ 10C	CFPJR 10C	10.063	10.085	18.979	19	54.7	55.3	24.5	14	2.932	616	309
CFPJ 12	CFPJR 12	12	12.016	12.043	CFPJ 12C	CFPJR 12C	12.066	12.093	20.979	21	56.7	57.3	25.5	15	3.770	792	398
CFPJ 13	CFPJR 13	13	13.016	13.043	CFPJ 13C	CFPJR 13C	13.066	13.093	22.979	23	60.7	61.3	27.5	16	4.356	915	459
CFPJ 16	CFPJR 16	16	16.016	16.043	CFPJ 16C	CFPJR 16C	16.066	16.093	27.979	28	69.7	70.3	32	20	6.702	1407	707
CFPJ 20	CFPJR 20	20	20.020	20.053	CFPJ 20C	CFPJR 20C	20.096	20.129	31.975	32	79.7	80.3	36	22	9.215	1935	972
CFPJ 25	CFPJR 25	25	25.020	25.053	CFPJ 25C	CFPJR 25C	25.096	25.129	39.975	40	111.7	112.3	52	33	17.279	3629	1822
CFPJ 30	CFPJR 30	30	30.020	30.053	CFPJ 30C	CFPJR 30C	30.096	30.129	44.975	45	122.7	123.3	56.5	35	21.991	4618	2319
CFPJ 35	CFPJR 35	35	35.020	35.053	CFPJ 35C	CFPJR 35C	35.096	35.129	51.970	52	134.7	135.3	62.5	40	29.322	6158	3092
CFPJ 40	CFPJR 40	40	40.025	40.064	CFPJ 40C	CFPJR 40C	40.127	40.166	59.970	60	150.7	151.3	69	44	36.861	7741	3887
CFPJ 50	CFPJR 50	50	50.025	50.064	CFPJ 50C	CFPJR 50C	50.127	50.166	79.965	80	191.7	192.3	89.5	70	73.304	15394	7730
CFPJ 60	CFPJR 60	60	60.030	60.076	CFPJ 60C	CFPJR 60C	60.182	60.228	89.965	90	208.7	209.3	95.5	73	91.735	19264	9673

NOTES: Formula used for effective surface area is $(\pi * ID * L)/3$
 Max static load is effective surface area times max load for FrelonGOLD®
 - 210 kgf/cm² is the rating for FrelonGOLD®
 - 105.45 kgf/cm² is the rating for FrelonJ®
 Frelon pads in each end (F dimension)

MOUNTING DIMENSIONAL INFORMATION

PART NO.		K SQUARE	Df O.D.	T LENGTH	Dp BOLT CIRCLE	X HOLE	Y C'BORE DIA.	Z C'BORE DEPTH	CLAMPING BOLT	CONCENTRICITY	SQUARENESS	CFPJ WEIGHTS (kg.)	CFPJR WEIGHTS (kg.)
CFPJ 06	CFPJR 06	22	28	8	20	3.5	6	3.1	M 3	0.015	0.015	0.015	0.018
CFPJ 08	CFPJR 08	25	32		24							0.024	0.028
CFPJ 10	CFPJR 10	30	40		29							0.044	0.053
CFPJ 12	CFPJR 12	32	42	9	32	4.5	7.5	4.1	M 4	0.015	0.015	0.051	0.060
CFPJ 13	CFPJR 13	34	43		33							0.063	0.071
CFPJ 16	CFPJR 16	37	48		38							0.096	0.107
CFPJ 20	CFPJR 20	42	54	11	43	5.5	9	5.1	M 5	0.017	0.017	0.133	0.149
CFPJ 25	CFPJR 25	50	62		51							0.270	0.286
CFPJ 30	CFPJR 30	58	74		60							0.360	0.397
CFPJ 35	CFPJR 35	64	82	14	67	6.6	11	6.1	M 6	0.017	0.017	0.501	0.547
CFPJ 40	CFPJR 40	75	96		78							0.776	0.856
CFPJ 50	CFPJR 50	92	116		98							1.780	1.885
CFPJ 60	CFPJR 60	106	134	24	112	11.0	17	11.1	M 10	0.025	0.025	2.329	2.519

The data and specifications in this publication have been carefully compiled and are believed to be accurate and correct. However, it is the responsibility of the user to determine and ensure the suitability of Pacific Bearing® products for a specific application. Pacific Bearing's only obligation will be to repair or replace without charge, any defective components if returned promptly. No liability is assumed beyond such replacement. *Consult www.pacific-bearing.com for the latest technical updates.

Flange Bearings

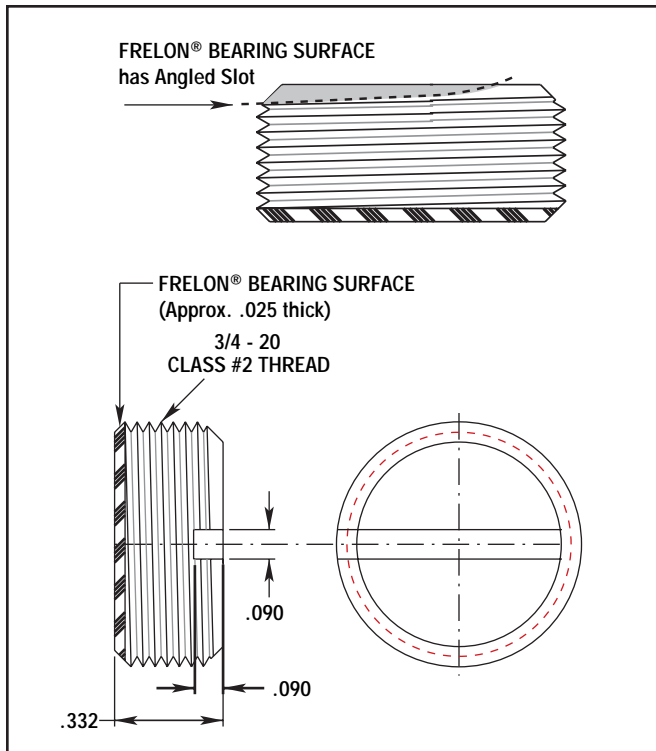
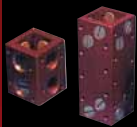

ADJUSTABLE BEARING PLUGS

Plug material is 316 stainless steel.

BEARING MATERIAL: FrelonJ® is standard for stainless square steel shafting (APN16 - E). FrelonGold® is also available for applications to be run on steel.

- Bearing plugs can be purchased separately
- Ideal for use in many applications as a wear pad
- Bearing surface area = .300 in²
- MAX Static Load Capacity per Plug = 450 lbs.
- The use of green Loctite is recommended to hold the adjustable bearing plugs in position

SQUARE BEARING BENEFITS & FEATURES

- Runs on a single, square shaft eliminating costly components
- Maintains radial integrity and can eliminate the need for parallel shafting
- Can be mounted in any orientation
- Housings are aluminum alloy with a standard anodized finish
- Utilizes standard bearing plugs
- Adjustable to maintain tight running clearances, contingent upon shafting
- Bearing plugs are easily replaced

ORDERING INFORMATION

PART NO.	DESCRIPTION
APN16E	Standard - Adjustable bearing plug with FrelonJ® bearing liner. Use with 300 series stainless or soft shafting.
APN16	Optional - Adjustable bearing plug with FrelonGOLD® bearing liner. Use with steel shafting.



SAME CHARACTERISTICS OF THE STANDARD ROUND-WAY SIMPLICITY® BEARINGS:

- Self-lubricating
- High load capacity
- Wide temperature range (-400°F/+400°F)
(-240°C/+240°C)
- Excel in contaminated environments
- High shock loading abilities
- Low wear rates

The data and specifications in this publication have been carefully compiled and are believed to be accurate and correct. However, it is the responsibility of the user to determine and ensure the suitability of Pacific Bearing® products for a specific application. Pacific Bearing's only obligation will be to repair or replace without charge, any defective components if returned promptly. No liability is assumed beyond such replacement. *Consult www.pacific-bearing.com for the latest technical updates.



CUT-AWAY VIEW

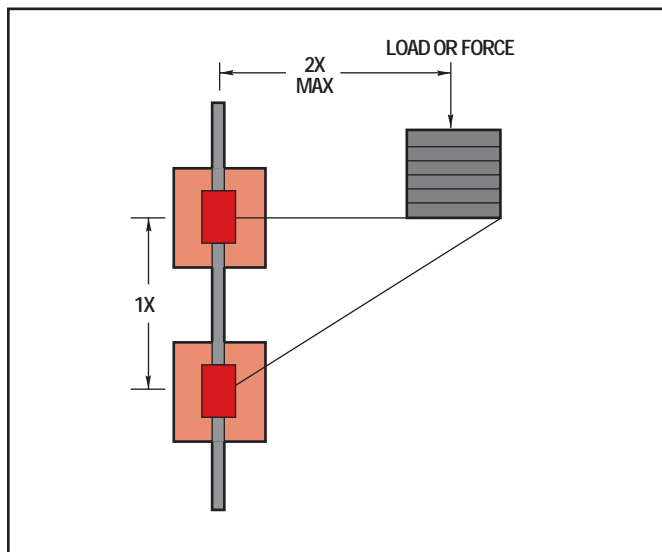
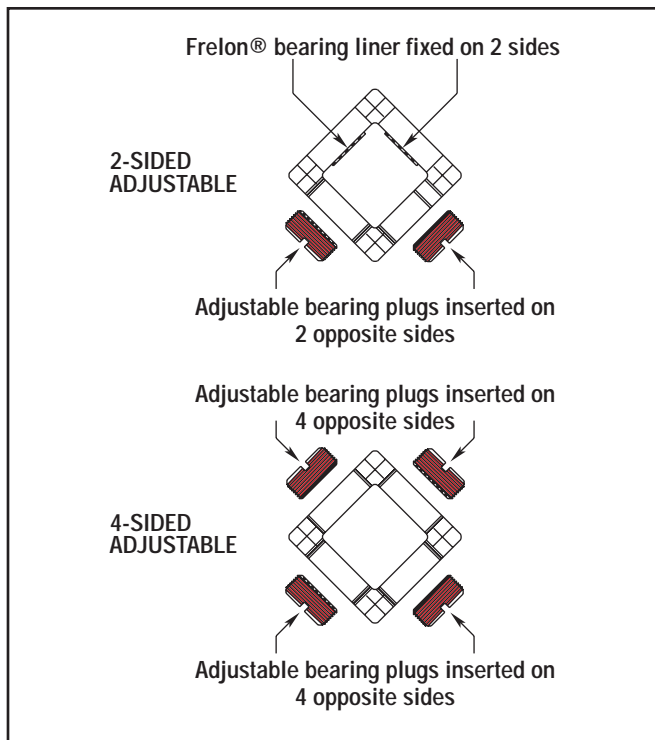
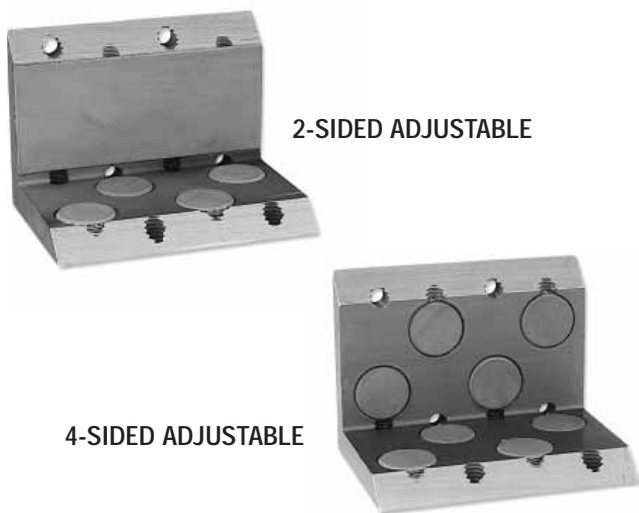

APPLICATION NOTE

Use green Loctite to hold the adjustable bearing plugs in position.

Two parameters must be met in the design and use of square bearings:

1. The 2:1 ratio for cantilevered loads applies to square bearings in the same way as roundway Simplicity[®] bearings. Binding will occur if the ratio is not met! **NOTE:** if only one bearing is used, the 2:1 applies from plug centers.
2. The maximum load and moment load must be met. To calculate the acceptable cantilever or lever arm, multiply the length (from center of the bearing to the center of the load) times the weight. The result must be less than the moment load for that orientation.

EXAMPLE: Distance of cantilever = 3"
 Amount of load = 40 lbs.
 3" x 40 lbs. = 120 in.-lbs.

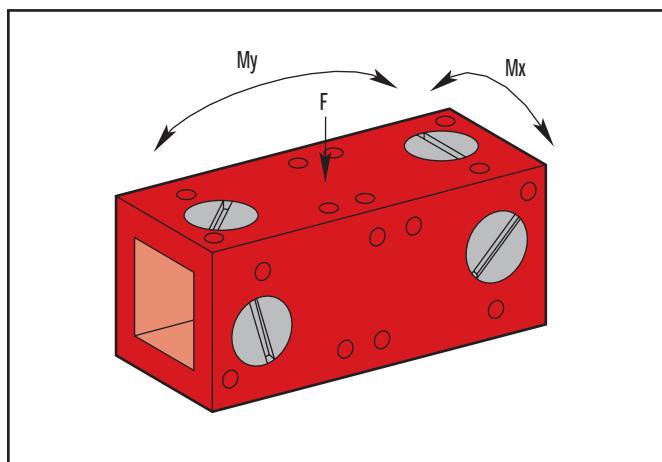

NOTE: Square Shafting on page 37.

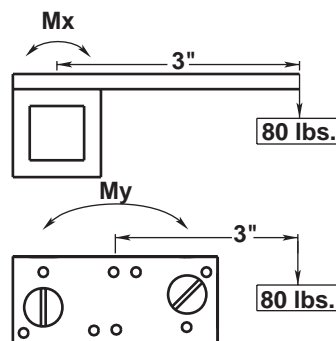

SQUARE BEARING LOAD INFORMATION

PART NO.	MAXIMUM MOMENTS (TORSIONAL CAPACITIES) (in.-lbs.)		MAXIMUM FORCE (lbs.)
	Mx	My	
SB16	74	165	920
SBL16		475	
SB24	416	402	1840
SBL24		1413	



Simplicity[®] Square Bearings

1.0" Specifications

Linear Motion Systems

"SB16-2" 1.0" 2-Sided adjustable square bearing
 "SB16-4" 1.0" 4-Sided adjustable square bearing

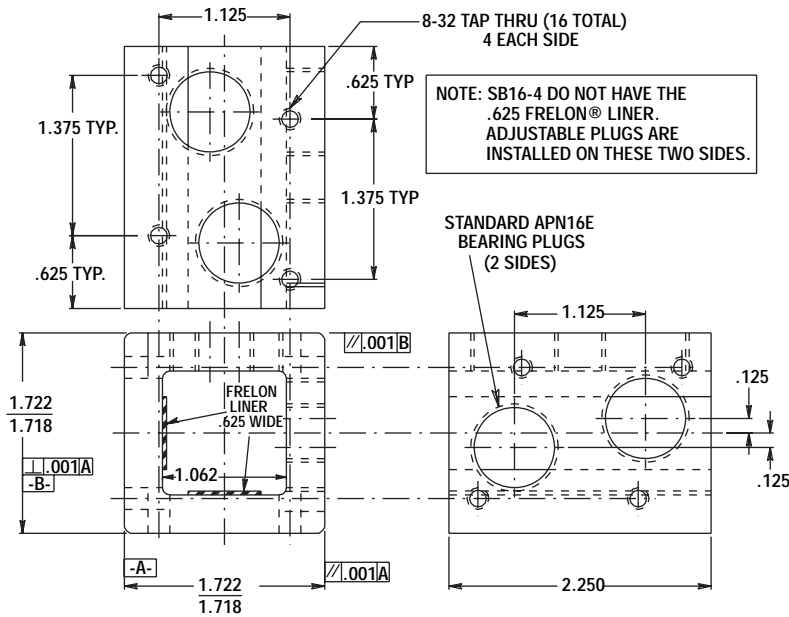

ORDERING INFORMATION

PART NO.	DESCRIPTION	BEARING WEIGHT (lbs.)
SB16-2E	Standard 1.0" two-sided adjustable square bearing with FrelonJ [®] plugs for stainless steel shafting	.48
SB16-2	Optional 1.0" two-sided adjustable square bearing with FrelonGOLD [®] plugs for steel shafting	
SB16-4E	Standard 1.0" four-sided adjustable square bearing with FrelonJ plugs for stainless steel shafting	.56
SB16-4	Optional 1.0" four-sided adjustable square bearing with FrelonGOLD plugs for steel shafting	
SBL16-2E	Standard 1.0" extended length, two-sided adjustable square bearing with FrelonJ plugs for stainless steel shafting	.77
SBL16-2	Optional 1.0" extended length, two-sided adjustable square bearing with FrelonGOLD plugs for steel shafting	
SBL16-4E	Standard 1.0" extended length, four-sided adjustable square bearing with FrelonJ plugs for stainless steel shafting	.85
SBL16-4	Optional 1.0" extended length, four-sided adjustable square bearing with FrelonGOLD plugs for steel shafting	

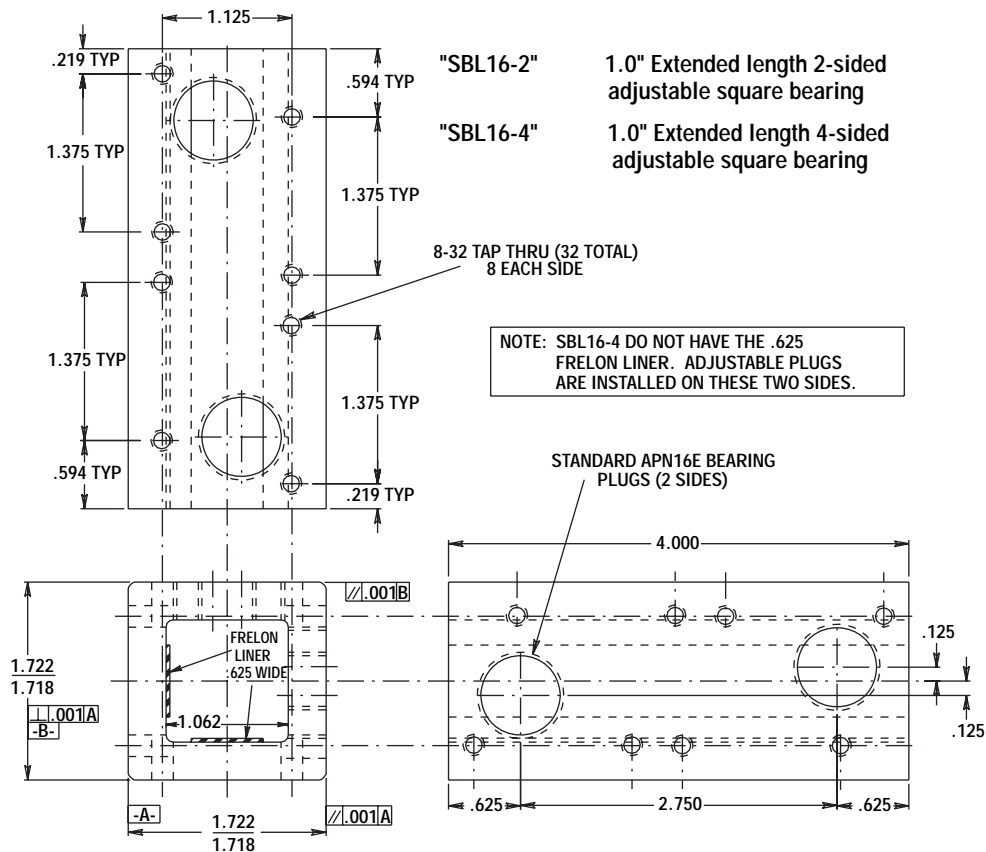

NOTE: Square Shafting on page 37.

The data and specifications in this publication have been carefully compiled and are believed to be accurate and correct. However, it is the responsibility of the user to determine and ensure the suitability of Pacific Bearing[®] products for a specific application. Pacific Bearing's only obligation will be to repair or replace without charge, any defective components if returned promptly. No liability is assumed beyond such replacement. *Consult www.pacific-bearing.com for the latest technical updates.

1.0" Square Bearings



Simplicity[®] Square Bearings

1.5" Specifications

"SB24-2" 1.5" 2-Sided adjustable square bearing
 "SB24-4" 1.5" 4-Sided adjustable square bearing

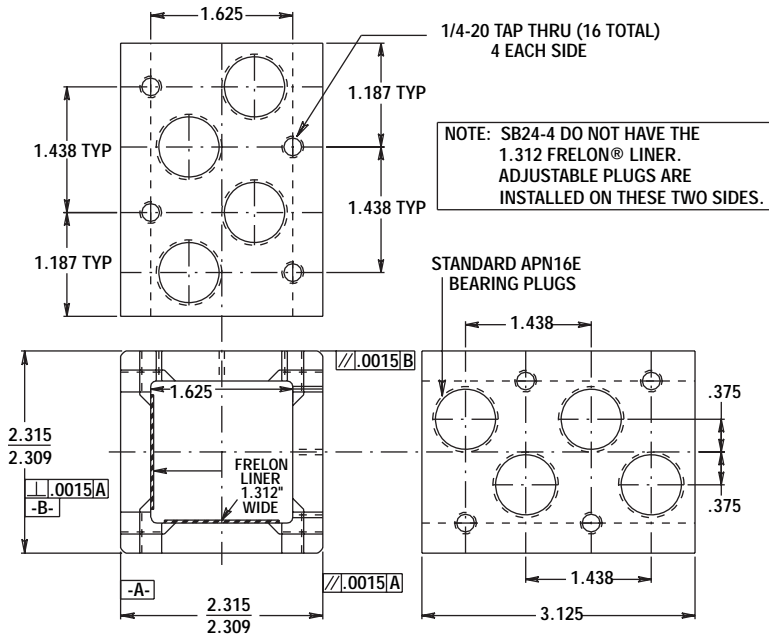

ORDERING INFORMATION

PART NO.	DESCRIPTION	BEARING WEIGHT (lbs.)
SB24-2E	Standard 1.5" two-sided adjustable square bearing with FrelonJ [®] plugs for stainless steel shafting	.96
SB24-2	Optional 1.5" two-sided adjustable square bearing with FrelonGOLD [®] plugs for steel shafting	
SB24-4E	Standard 1.5" four-sided adjustable square bearing with FrelonJ plugs for stainless steel shafting	1.12
SB24-4	Optional 1.5" four-sided adjustable square bearing with FrelonGOLD plugs for steel shafting	
SBL24-2E	Standard 1.5" extended length, two-sided adjustable square bearing with FrelonJ plugs for stainless steel shafting	1.71
SBL24-2	Optional 1.5" extended length, two-sided adjustable square bearing with FrelonGOLD plugs for steel shafting	
SBL24-4E	Standard 1.5" extended length, four-sided adjustable square bearing with FrelonJ plugs for stainless steel shafting	1.84
SBL24-4	Optional 1.5" extended length, four-sided adjustable square bearing with FrelonGOLD plugs for steel shafting	

1.5" Square Bearings

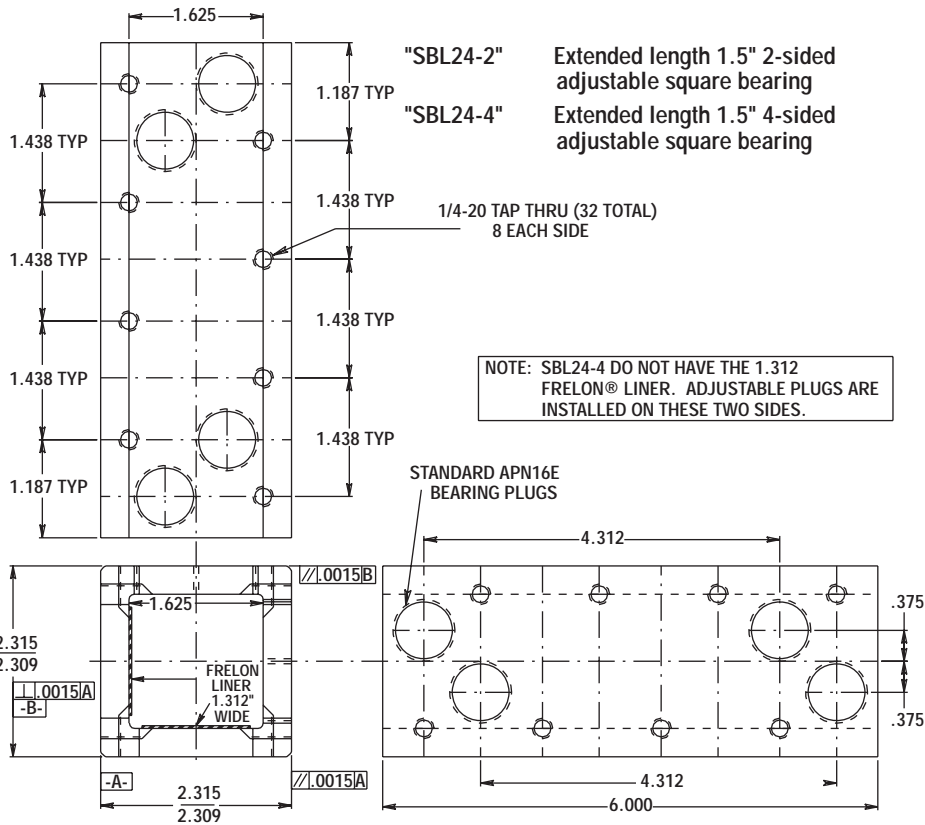

NOTE: Square Shafting on page 37.

The data and specifications in this publication have been carefully compiled and are believed to be accurate and correct. However, it is the responsibility of the user to determine and ensure the suitability of Pacific Bearing[®] products for a specific application. Pacific Bearing's only obligation will be to repair or replace without charge, any defective components if returned promptly. No liability is assumed beyond such replacement. *Consult www.pacific-bearing.com for the latest technical updates.

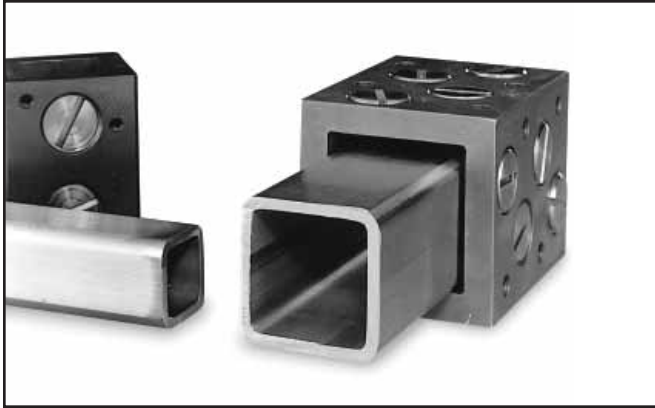
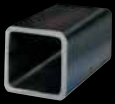

SQUARE SHAFTING

- 304 Stainless steel (standard) is highly corrosion resistant
- Buffed and polished to provide an excellent running surface for FrelonJ®
- Both 1" and 1.5" available cut to any length up to 10 feet
- Wall thickness is $\cong .120$ "

ORDERING INFORMATION

PART NO.	DESCRIPTION	WT. (lbs./in.)
PST16-xx	Standard 1.0" 304 stainless steel square shafting	0.12
PST24-xx	Standard 1.5" 304 stainless steel square shafting	0.18

xx - Specify length in inches. Cut charge applied.

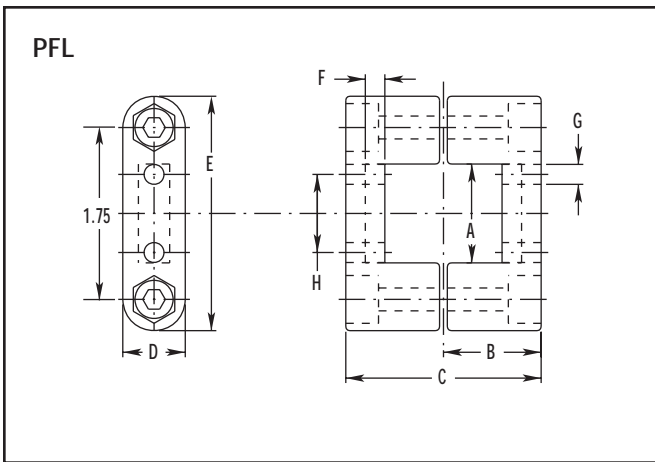

SQUARE MOUNTING ACCESSORIES

All mounting accessories are made from cast 356-T6 aluminum for good strength and corrosion resistance.

ORDERING INFORMATION (Square Clamps)

PART NO.	A	B	C	D	E	F	G	H
PFL1000	1.00	0.984	1.968	0.630	2.362	0.197	0.200	0.787
PFL1500	1.50	1.338	2.677	0.787	2.953	0.276	0.256	1.024

Includes 2 M6 x 1 Hex head bolts, 1.5" long

ORDERING INFORMATION (Flanged Base)

PART NO.	A	B	C	D	E	F	G	H	J
PBH1000	1.00	0.984	1.890	2.362	2.520	0.472	0.256	3.228	2.874
PBH1500	1.50	1.338	2.440	2.756	2.992	0.551	0.256	3.740	3.347

Other housing configurations are also available. Size specifications are available upon request.

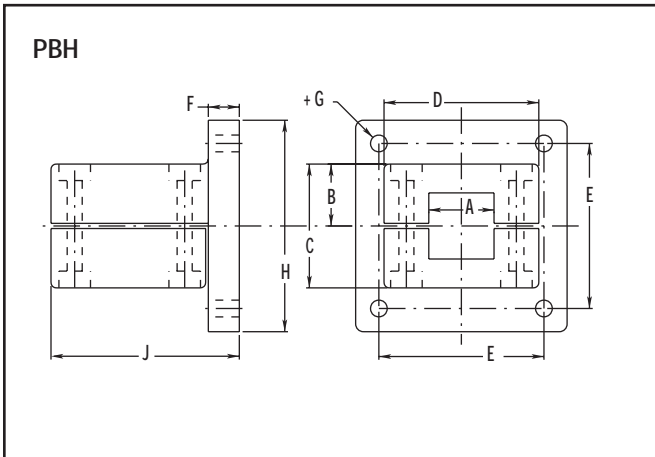

ANGLE BRACKET – 1 1/2" only
Part No. PAN1515



CROSS MOUNT – 1 1/2" only
Part No. P XK1515



CROSS MOUNT ROUND & SQUARE – 1 1/2" only
Part No. PXM1515

The data and specifications in this publication have been carefully compiled and are believed to be accurate and correct. However, it is the responsibility of the user to determine and ensure the suitability of Pacific Bearing® products for a specific application. Pacific Bearing's only obligation will be to repair or replace without charge, any defective components if returned promptly. No liability is assumed beyond such replacement. *Consult www.pacific-bearing.com for the latest technical updates.



Simplicity® Self-lubricating Bearings

What Makes Simplicity the Right Choice?

Linear Motion Systems

Technical Information

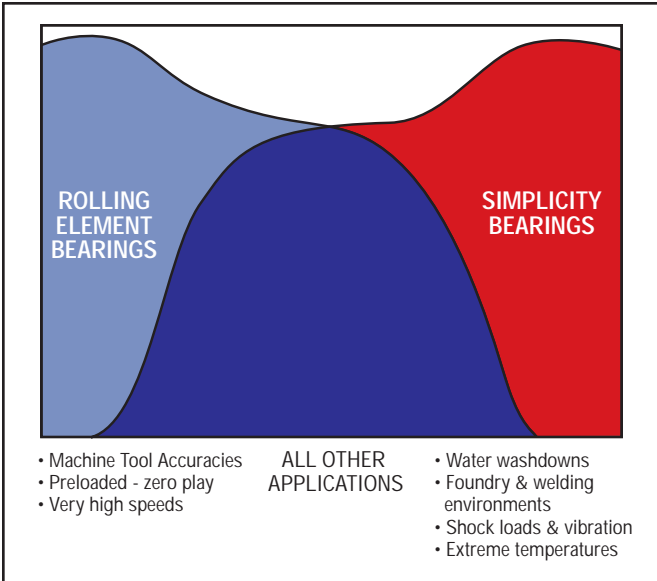

Plane bearing applications represent 25% of total worldwide bearing usage.

Why? Good engineering principles dictate the best bearing design for the application. Often ball bearings are asked to perform beyond their design capabilities. The rolling element industry has not helped users understand the limitations of their technology.

In 1983, linear ball bearing users came to Pacific Bearing® and asked for a linear bearing that simply would not fail. Dirt, vibration, shock loading, water washdowns, etc. were causing premature failure, often within days. After testing many material combinations, we chose the Simplicity design as the best solution.

In 1997, three years of rigorous development and testing resulted in the release of the next generation of plane bearing material – FrelonGOLD®. The original Simplicity bearings were improved with additional performance advantages. These are the advantages you will gain with Simplicity:

LINER

- Self-lubricating – requires no external lubricant
- Embeddability of hard particulate eliminates galling and shaft damage
- Dampens vibration for quiet and smooth operation

LOAD CAPACITY

- FrelonGOLD® supplies an average of 20x more load capacity than a standard linear ball bearing allowing the Design Engineer to use a more compact package
- Shock loads are absorbed without damage to components

PERFORMANCE

- Simultaneous linear, oscillating, and rotary motions expand possibilities
- Reliable friction characteristics that do not increase over the life of the bearing
- Liner material similar to energized Teflon® seals
- Close fit & wiping action - cleans shafting - eliminating the need for seals

LOW COST

- Average purchase price 15-30% less than rolling element linear bearings
- Operates maintenance free
- Reliable, predictable life
- WILL NOT CATASTROPHICALLY FAIL!!

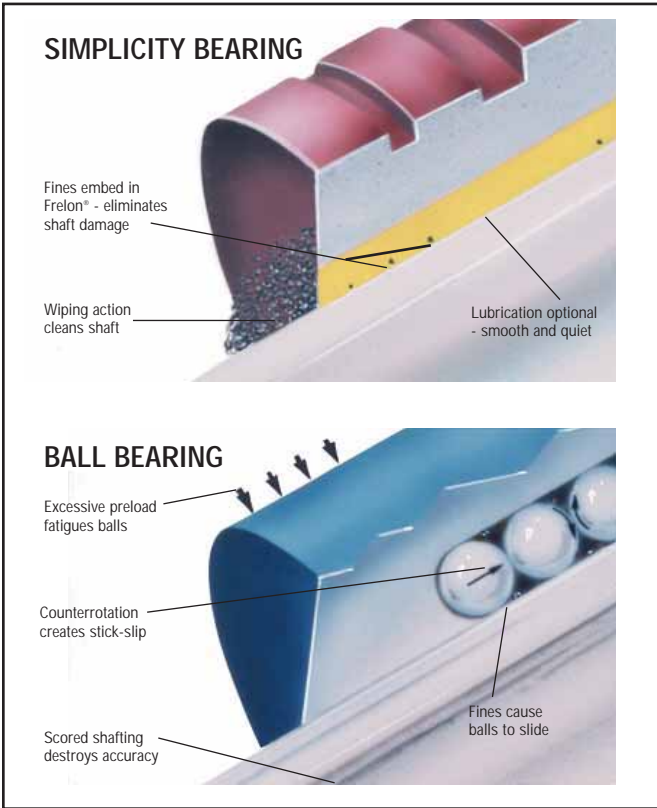

The data and specifications in this publication have been carefully compiled and are believed to be accurate and correct. However, it is the responsibility of the user to determine and ensure the suitability of Pacific Bearing® products for a specific application. Pacific Bearing's only obligation will be to repair or replace without charge, any defective components if returned promptly. No liability is assumed beyond such replacement. *Consult www.pacific-bearing.com for the latest technical updates.



Simplicity® Self-lubricating Bearings

What Gives Simplicity these Advantages?

Linear Motion Systems

THE FRELON® BEARING LINER MATERIALS

FrelonGOLD® and FrelonJ® are a compound of Teflon® and fillers developed for improved performance over other bearings. They provide low wear, low friction, self-lubrication, and high strength.

TEFLON FEATURES:

- Self-lubricating (runs without added lubricant)
- Embeddability of hard particulate
- Wide temperature range (-400°F/+400°F)
(-240°C/+240°C)
- Chemically inert
- Vibration dampening (NO metal-to-metal contact)

FILLER BENEFITS:

- High load capacity
- High strength
- Low wear rate vs. other materials

PACIFIC BEARING HAS COMBINED FRELON® WITH PRECISION BEARING TECHNOLOGY TO CREATE SIMPLICITY®

- The Frelon liner is bonded to the bearing shell at the molecular level, which transfers the load and dissipates heat buildup throughout the bearing
- Will not rust or corrode due to anodized aluminum or stainless steel shell
- Patented self-aligning capabilities are standard (See pages 41-42 for information)
- Provides both linear, oscillating, rotary, or any combination of motions
- Maintenance free operation
- Will not damage shafting
- Smooth, quiet operation
- Highly accurate – all critical surfaces are ground on precision bearing grinders
- WILL NOT CATASTROPHICALLY FAIL!

Teflon® is a registered trademark of Dupont Corporation

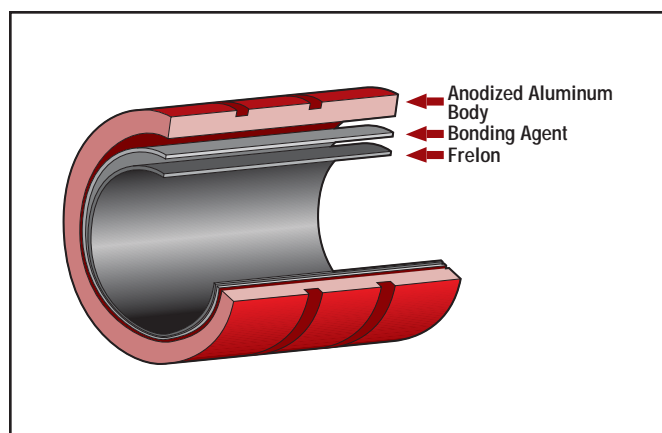
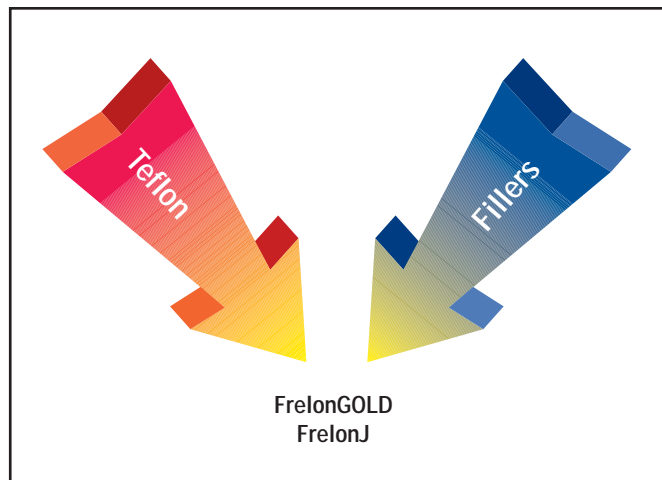

Technical Information

The data and specifications in this publication have been carefully compiled and are believed to be accurate and correct. However, it is the responsibility of the user to determine and ensure the suitability of Pacific Bearing® products for a specific application. Pacific Bearing's only obligation will be to repair or replace without charge, any defective components if returned promptly. No liability is assumed beyond such replacement. *Consult www.pacific-bearing.com for the latest technical updates.



FrelonGOLD®



FrelonJ®



Bearing Plug Shown - See Page 33.

RUNNING CLEARANCE

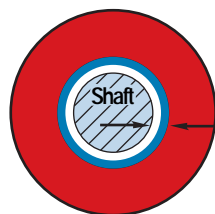

Standard "FL"
Performs like a preloaded linear ball bearing

.0005" per side clearance average
(.0127 mm)

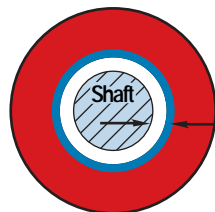

Compensated "FLC"
Performs like a standard linear ball bearing

.0015" + per side clearance average
(.0381 + mm)

STANDARD



Inch Series



ISO Metric Series



JIS Metric Series

OPTIONAL



316 Stainless Steel

BEARING LINER MATERIAL

Simplicity bearings are available with three liner materials.

FrelonGOLD is a dark gold colored high performance material with gold-colored fillers and is compatible with standard RC60 hardened steel shafting, RC70 ceramic coated Feather Shafting™ and 440 stainless steel shafting.

Frelon J is a yellow colored material specially formulated to provide the optimum performance with 300 series stainless steel and softer shafting like bare aluminum.

RUNNING CLEARANCE

Simplicity bearings are available with two classes of running clearance.

PRECISION—"FL":

- Performs like a preloaded ball bearing
- Tightest running clearance approximately .001" (.025mm)
- Use in applications that require high precision

CAUTION: Not recommended for all parallel shaft applications. Any misalignment can cause binding on the shaft. See recommended "FLC".

COMPENSATED—"FLC":

- Performs like a standard ball bearing
- Additional clearance built into the I.D. (all other dimensions are the same as the precision bearings)
- Ideally suited for parallel shaft applications

NOTE: Many parallel shaft applications will run "FL" precision on one rail and "FLC" compensation on the opposite rail to accommodate slight misalignments.

BEARING SHELL

Simplicity bearings are available in a variety of configurations to help meet specific application needs.

- Standard is aluminum alloy with anodized finish (standard)
- Special 316 stainless steel (no plating) (optional)

The data and specifications in this publication have been carefully compiled and are believed to be accurate and correct. However, it is the responsibility of the user to determine and ensure the suitability of Pacific Bearing® products for a specific application. Pacific Bearing's only obligation will be to repair or replace without charge, any defective components if returned promptly. No liability is assumed beyond such replacement. *Consult www.pacific-bearing.com for the latest technical updates.



BEARING SHELL (cont.)

MATERIALS:

Aluminum Alloy – Is a heat treated and artificially aged aluminum with good strength and corrosion resistance.

316 Stainless Steel – Has an excellent corrosion resistance and is widely used by the paper, food, and other industries.

FINISHES:

Standard Anodized – A sulfuric bath anodizing with a nickel acetate seal that will stand up to 14 days exposure in a 5% salt spray solution at 96°F. It is applied at a .0002" thickness.

NOTE: See page 62 for details on chemical resistance.

TOLERANCES:

- All bearings are precision ground both I.D. and O.D. to provide the highest quality.
- Statistical Process Control (SPC) capabilities also increase final quality.

SELF-ALIGNMENT FEATURE

Simplicity bearings are available with a standard straight O.D. or a crowned self-aligning O.D.

"FL" – (Standard):

- Straight O.D.
- Pacific Bearing standard pillow blocks have the self-aligning capability designed into the block using standard "FL" bearings for the final assembly

"FLA" – (Self-aligning O.D.):

- Has a crown on the O.D. allowing the bearing to re-align itself in binding situations
- Specifically designed to easily retrofit straight bore housings
- The bearing will allow 1/2° of misalignment capability from centerline (1° overall).
- O-rings are used on either side of the crown. This cushions and eliminates clatter in operation.

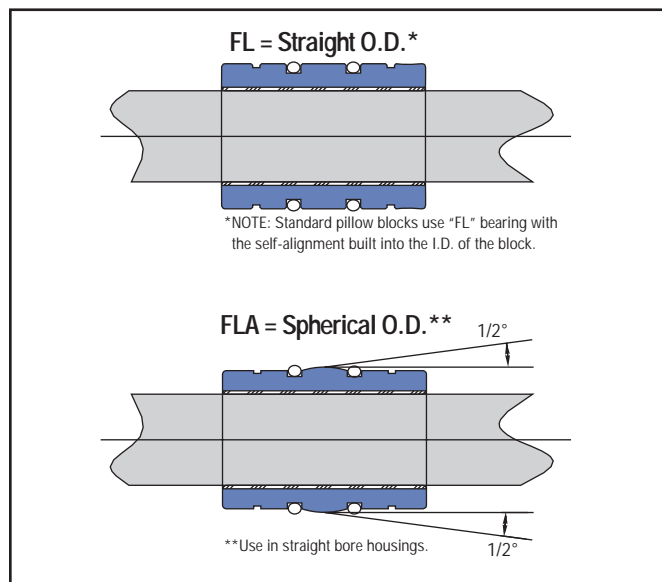
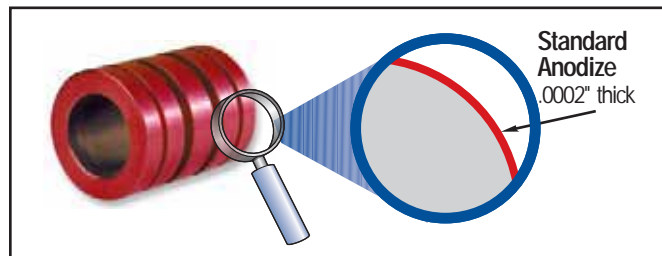

The data and specifications in this publication have been carefully compiled and are believed to be accurate and correct. However, it is the responsibility of the user to determine and ensure the suitability of Pacific Bearing® products for a specific application. Pacific Bearing's only obligation will be to repair or replace without charge, any defective components if returned promptly. No liability is assumed beyond such replacement. *Consult www.pacific-bearing.com for the latest technical updates.

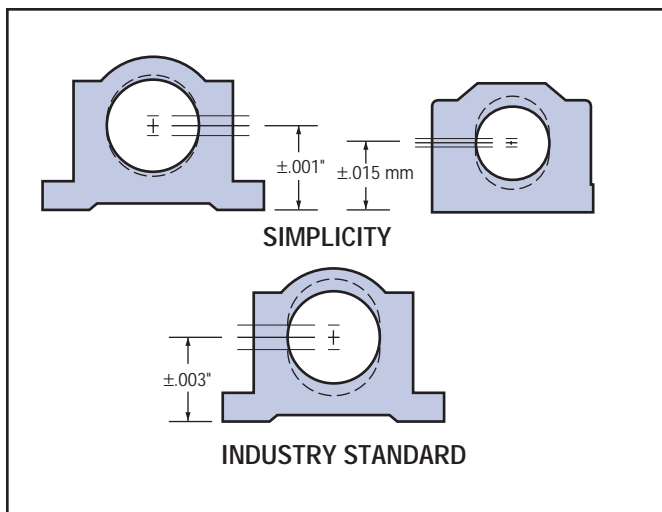
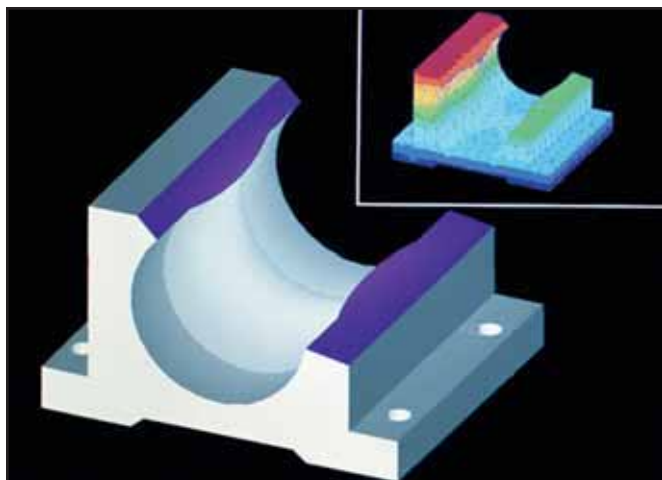

PILLOW BLOCKS

- Made of aluminum alloy
- Pillow blocks are interchangeable with industry standard ball bearing pillow blocks
- Critical centerline dimensions hold accuracy within $\pm.001$ " on inch sizes and $\pm.015$ mm on metric sizes

FINISHES:

- Clear anodized finish (Standard)

Standard pillow blocks have built-in self-alignment in all directions.

- Standard pillow blocks have $1/2^\circ$ misalignment from centerline.
- This feature is built into the housing with a patented spherical radius at the midpoint of the block.
- This self-aligning capability will allow for some shaft deflection and misalignment.

Rigid or straight bore housings are available.

- This does not allow for any self-alignment and provides a very rigid assembly.
- They are typically used in single shaft applications.

ADDITIONAL FEATURES

O-Rings – Used in standard pillow blocks and with self-aligning bearings.

Nitrile Buna 70 (standard) – A good general purpose rubber that is used in 98% of applications.
-65°F to 275°F (-50°C to 135°C)

Viton (special – designate with "V") – Used only in high temperature applications up to 400°F (up to 204°C).



The data and specifications in this publication have been carefully compiled and are believed to be accurate and correct. However, it is the responsibility of the user to determine and ensure the suitability of Pacific Bearing® products for a specific application. Pacific Bearing's only obligation will be to repair or replace without charge, any defective components if returned promptly. No liability is assumed beyond such replacement. *Consult www.pacific-bearing.com for the latest technical updates.



PILLOW BLOCKS - ADDITIONAL FEATURES (cont.)

SEALS: Use only in the most contaminated environments.

Polymod® (standard) – A high performance polymer modified material that reduces friction of a standard buna material by 50% and increases wear life

*Polymod is a registered trademark of Polymod Technologies, Inc.

Temperature – -40 – +400°F

Urethane (special - designate with “U”) – A moly-impregnated urethane scraper that is only for the severest applications - friction is greatly increased!

Temperature – -40 – +180°F

Viton™ (special - designate with “V”) – Used only in high temperature applications up to 400°F (up to 204°C).

ATTENTION: 90% of applications do not require seals when using Simplicity bearings. The liner has a natural ability to wipe particles from the shafting. Any particulate (metal, sand, etc.) that does enter the bearing will embed itself into the soft liner not scoring the shafting or locking mechanical parts.

LUBRICATION SYSTEM: Order with “JKM” modifier

- Recommended for high speed, high load, and rotary or oscillating applications

Lubrication System consists of:

Felt wick – Retains oil lubricants (remove when using grease lubrication)

Zerk fitting – Installed into pillow block, other housing, or directly into die sets PAC, PACM

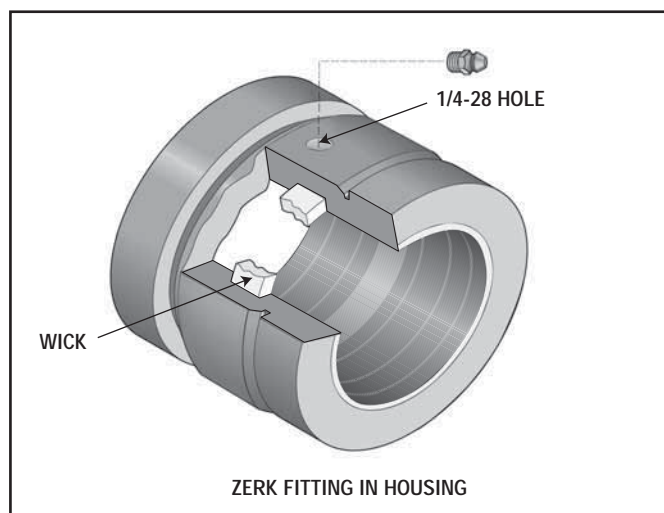

The data and specifications in this publication have been carefully compiled and are believed to be accurate and correct. However, it is the responsibility of the user to determine and ensure the suitability of Pacific Bearing® products for a specific application. Pacific Bearing's only obligation will be to repair or replace without charge, any defective components if returned promptly. No liability is assumed beyond such replacement. *Consult www.pacific-bearing.com for the latest technical updates.

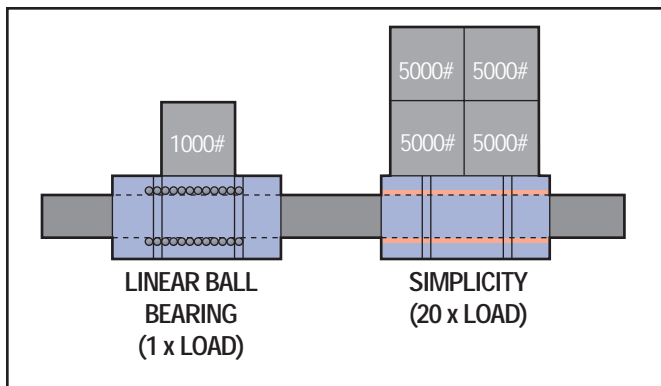

LOAD CAPACITY OF LINER

Simplicity bearings can carry from 4 to 20 times the load of a linear ball bearing.

BEARING MATERIAL	STATIC LOAD CAPACITY
FrelonGOLD®	20.68 N/mm ²
FrelonJ®	10.34 N/mm ²

- Allows the engineer to maintain performance in a smaller designed package

Example: Simplicity 1/2" I.D. = 1" I.D. linear ball bearing

- Shock loads and vibration are absorbed
- Metal to metal contact is eliminated providing a smoother, quieter running assembly

SPEED CHARACTERISTICS

Exceeding these speeds causes frictional heat and accelerates liner wear.

BEARING MATERIAL	NO LUBE CONTINUOUS MOTION	NO LUBE INTERMITTENT MOTION	WITH LUBRICATION*
FrelonGOLD	300 sfm	825 sfm	825 sfm
	60 in./sec.	165 in./sec.	165 in./sec.
	1.524 m/sec.	4.19m/sec.	4.19 m/sec.
FrelonJ	140 sfm	400 sfm	400 sfm
	28 in./sec.	80 in./sec.	80 in./sec.
	.711 m/sec.	2.03 m/sec.	2.03 m/sec.

*Depending on the lubrication used, loads, and frequency of continuous or intermittent motion, speeds can be in excess of the numbers shown.

PERFORMANCE RATINGS (for Linear Motion)

Plane bearings are rated by their limiting PV which is a combination of load over a given surface area and the velocity.

BEARING MATERIAL	MAX. "PV"	MAX. "P"	MAX. "V" (NO LUBRICATION)
FrelonGOLD	20,000 (psi) x ft./min.)	3000 psi	300 sfm
	430 (kgf/cm ² x m/min.)	210.9 kgf/cm ²	91.44 m/min.
FrelonJ	10,000 (psi x ft./min.)	1500 psi	140 sfm
	215 (kgf/cm ² x m/min.)	105.45 kgf/cm ²	42.66 m/min.

PV = The performance measurement of plane bearings

PV = P x V where P = pressure (load) in psi (kgf/cm²)

V = velocity (speed) in sfm (m/min.)

NOTE: All 3 parameters must be met by an application for the bearing to perform properly.

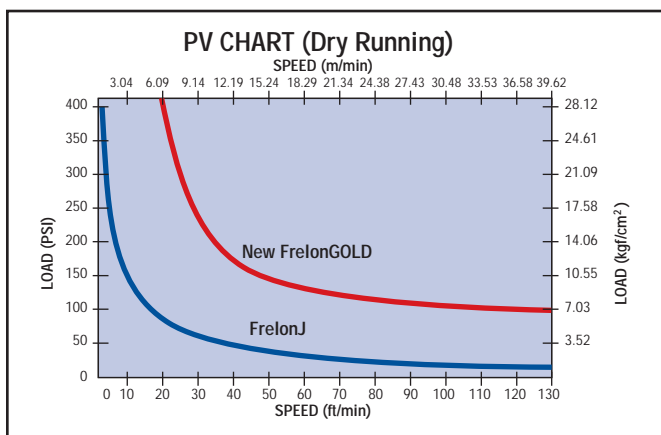
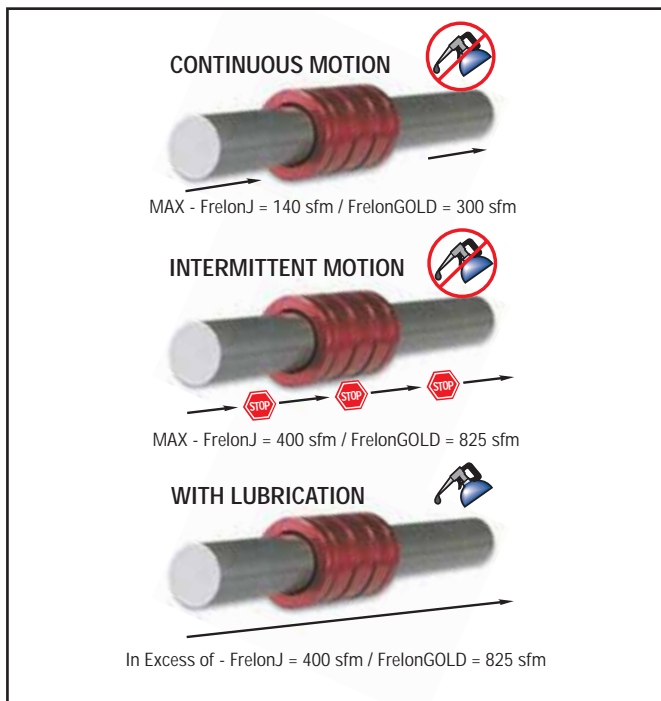

The data and specifications in this publication have been carefully compiled and are believed to be accurate and correct. However, it is the responsibility of the user to determine and ensure the suitability of Pacific Bearing® products for a specific application. Pacific Bearing's only obligation will be to repair or replace without charge, any defective components if returned promptly. No liability is assumed beyond such replacement. *Consult www.pacific-bearing.com for the latest technical updates.



WEAR RATE/LIFE EXPECTANCY

The life expectancy of a Simplicity bearing is dependent on application parameters.

Factors that will affect life...

- Shaft hardness, surface finish, and preparation
- Length of travel • Temperature
- Contamination • Running clearance
- Lubrication • Speed
- And many, many other factors

The Radial Wear chart gives a guideline for a typical application at 10 psi (.703 kgf/cm²) traveling at 100 ft./min. (30.48 m/min.).

FACTORS AFFECTING WEAR RATE/LIFE

Shafting requirements for Frelon® bearing materials.

BEST PERFORMANCE:

- Finish of 8 - 12 RMS
- Hardness of RC60

ACCEPTABLE PERFORMANCE:

- Finish of 8 - 16 RMS
- Hardness of RC35
- Surface finish requirements apply to all three Frelon bearing materials.
- Rougher shafting can be used, but both bearing and shafting will wear at accelerated rates and binding may occur.

NOTE: Consult factory if using chrome plated shafting.

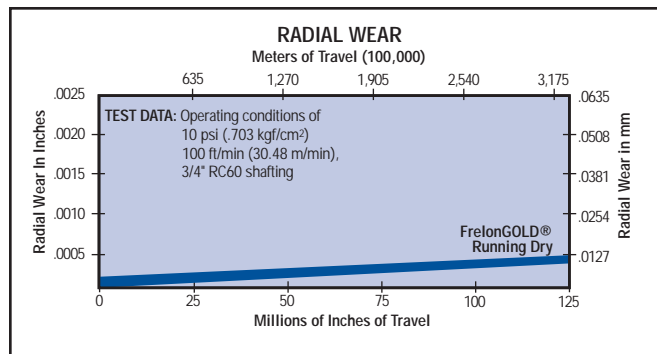

The data and specifications in this publication have been carefully compiled and are believed to be accurate and correct. However, it is the responsibility of the user to determine and ensure the suitability of Pacific Bearing® products for a specific application. Pacific Bearing's only obligation will be to repair or replace without charge, any defective components if returned promptly. No liability is assumed beyond such replacement. *Consult www.pacific-bearing.com for the latest technical updates.



FRELON® TRANSFER PROCESS

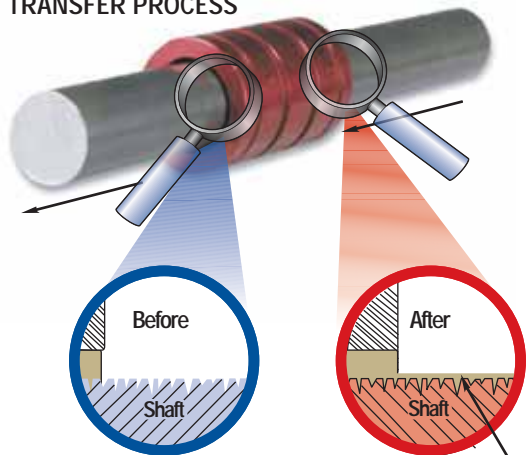

NOTE: At break-in, Frelon deposits a microscopic film on the shaft and fills the valleys in the surface finish creating a Frelon-on-Frelon running condition that is true self-lubrication.

RECOMMENDED LUBRICATION

- Waylube Oil
- Light Weight Oils
- Petroleum Based Grease
- 3-in-1 oils



NOT RECOMMENDED

- WD-40
- PTFE Sprays
- Fluorocarbons
- Silicon Oils, Grease or Spray



WD40® is a registered trademark of the WD40 company

TRANSFER PROCESS OF LINER TO SHAFT

The interaction of the Frelon® material and the shafting creates a natural, microscopic transfer of the Frelon to the running surface. A thin film is deposited on the shaft, and the valleys in the surface finish are filled in with Frelon material during the initial break-in period. This transfer creates the self-lubricating condition of Frelon riding on Frelon.

This break-in period will vary depending on several criteria:

1. Preparation of the shafting prior to installation - it is best to clean the shafting with a 3-in-1 type oil before installing the bearings. This ensures that the surface will receive a full transfer of material.
2. Speed, load, and length of stroke specific to the application - typically the initial transfer process will take approximately 50-100 strokes of continuous operation. The running clearance on the bearing will increase an average of .0002" to .0005", depending on the length of the stroke and surface requiring the transfer.
3. How often the shafting is cleaned - if the shafting is cleaned regularly, increased wear will be seen in the bearings. This is due to the transfer process being performed over and over again.

CAUTION: Do not repeatedly clean the shafting with alcohol! This will remove the previously transferred material entirely and increase the wear to the bearing liner.

LUBRICATION

Lubrication can...

- Reduce friction up to 50%.
- Minimize wear of liner.
- Reduce heat buildup allowing greater speeds. Actual speeds achieved are dependent on type of lubricant and frequency of application.
- Aid in cleaning the shafting for a proper transfer process. A minimum of initial lubrication of Simplicity bearings is strongly recommended.

The data and specifications in this publication have been carefully compiled and are believed to be accurate and correct. However, it is the responsibility of the user to determine and ensure the suitability of Pacific Bearing® products for a specific application. Pacific Bearing's only obligation will be to repair or replace without charge, any defective components if returned promptly. No liability is assumed beyond such replacement. *Consult www.pacific-bearing.com for the latest technical updates.



TEMPERATURE

Simplicity bearings can operate in a wide range of temperatures (-400°F/+400°F) (-240°C /+240°C). Temperature dependent on materials housed in pillow block and size of bearing.

- Maintains the same performance characteristics
- The thin liner allows heat to dissipate through the bearing shell

THERMAL EXPANSION

The standard bearing ID options are designed for use in most industrial applications.

For temperatures below 0° F, the standard I.D. is recommended. (FL series)

For extreme high temperatures, the Compensated I.D. bearing is recommended (FLC) for the increased running clearance.

CAUTION: It is always best to inspect actual size at extreme temperatures to insure proper running clearance.

ROTARY APPLICATIONS

Simplicity bearings will operate very well in rotary applications if applied properly.

Stationary rotary applications do not allow the heat to be spread over an extended area. It is retained in the I.D. of the bearing limiting speed and load.

- MAX Rotary Speed (No lube/continuous motion)
- 40 sfm (12.2 m/min.) for standard precision ID clearances
- 140 sfm (42.6 m/min.) for compensated ID clearances

$$V(\text{sfm}) = .262 \times d \times \text{RPM}$$

d = shaft diameter (inches)

RPM = revolutions per minute

- Properly maintained lubrication can increase these speeds dramatically.

CAUTION: It is always best to do specific testing for rotary applications above these limits where lubrication is to be used.

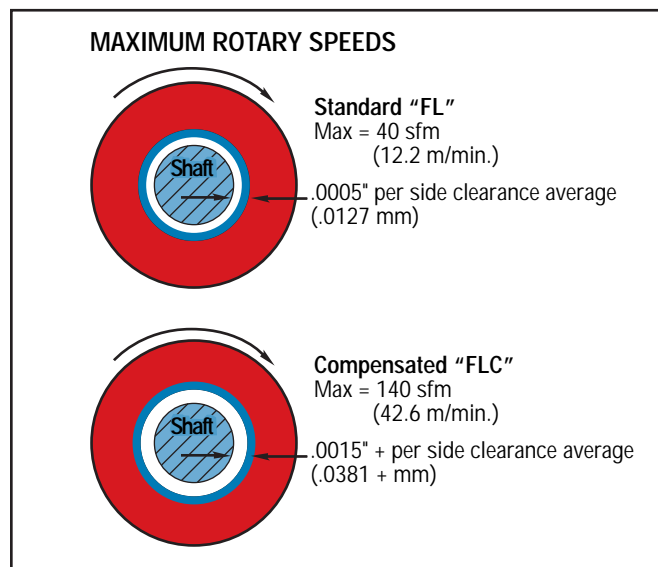
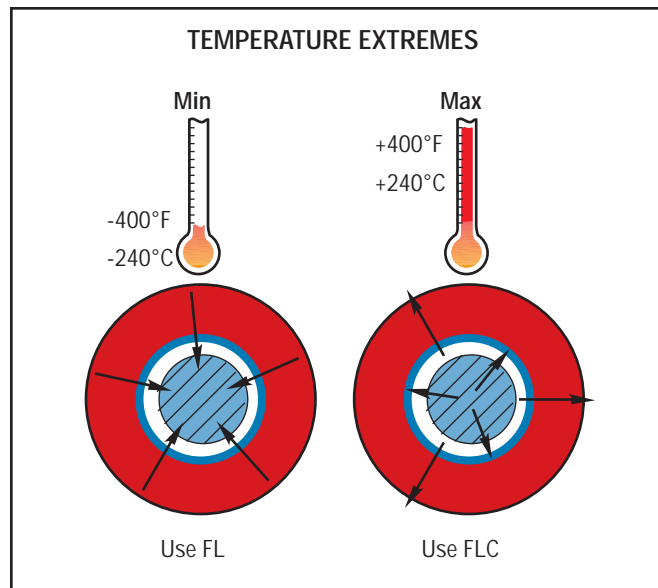

The data and specifications in this publication have been carefully compiled and are believed to be accurate and correct. However, it is the responsibility of the user to determine and ensure the suitability of Pacific Bearing® products for a specific application. Pacific Bearing's only obligation will be to repair or replace without charge, any defective components if returned promptly. No liability is assumed beyond such replacement. *Consult www.pacific-bearing.com for the latest technical updates.

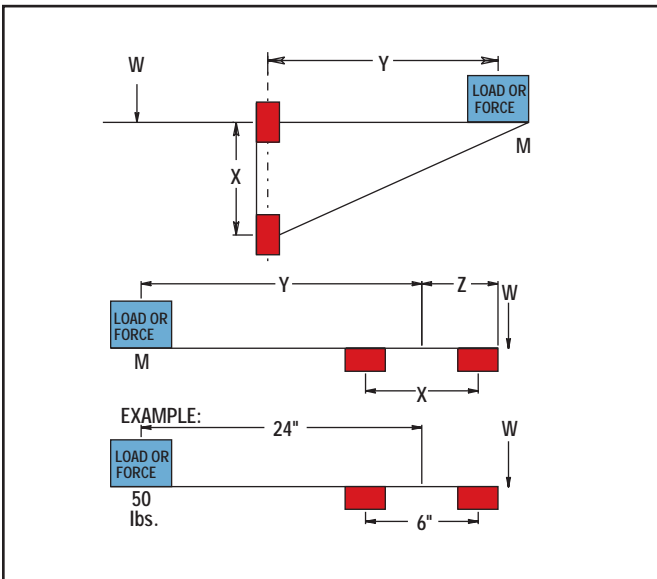
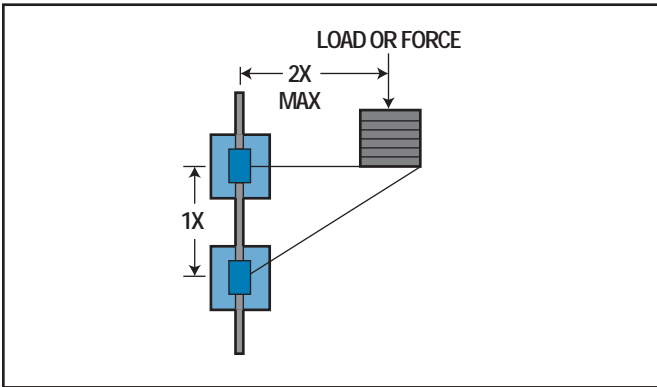
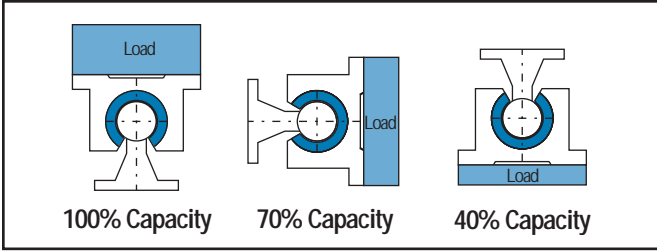

OPEN BEARINGS ORIENTATION

Simplicity bearings can operate in any orientation.

Load capacities will vary on open bearings depending on the orientation in which they are being used.

CANTILEVERED LOADS

- Maximum 2:1 ratio
- 1x = bearing separation on same shaft
- 2x = distance from shaft to load or force

EXAMPLE: If 2x equals 10" then 1x must be at least 5"

CAUTION: BINDING will occur if the 2:1 ratio is exceeded!

This principle is NOT load dependent! It is also NOT dependent on the driving force used! The bearings will bind whether hand or mechanically driven.

This principle is a product of friction.

What if more than 2:1 is required?

Often times holding the 2:1 ratio is not possible. One method of preventing binding problems in these cases is to use a counter balance.

For efficient counter balances, use this formula:

$$M * Y = W * Z$$

NOTES: To avoid problems when running without mass (M) $Z = 1.5X$

W can be calculated; load on bearing will be:

$$\frac{M + W}{\# \text{ of bearings}}$$

EXAMPLE: $50 * 24 = W * Z$ ($Z = 1.5 * 6 = 9$)

$$W = \frac{50 * 24}{9} = 133 \text{ lbs.}$$

$$\text{Load per bearing} = \frac{50 + 133}{4} = 45.75 \text{ lbs./bearing}$$



SEVERE MISALIGNMENT SOLUTIONS

Linear ball bearings will continue to operate in a misaligned condition, but will cause damage to shafting and catastrophically fail.

Simplicity bearings DO NOT tolerate misalignment. They simply will stop moving without any damage to the shafting.

Self-aligning housings will aid in misalignment - up to $1/2^\circ$ from centerline.

POSSIBLE SOLUTIONS for use with Standard "FL":

Undersize the bearing O.D. (see chart) and install o-rings. See product pages for o-ring numbers.

Oversize the housing I.D. (see chart) and install the standard bearing with o-rings. See product pages for o-ring part numbers.

The additional clearance created by either method will allow the bearing to float in the housing and match the non-parallelism of the shafting.

CAUTION: This solution is only for SEVERE cases that the standard self-aligning will not accommodate.

NOTE: Maximum additional clearance and o-ring information for severe misalignment solutions on page 61. For complete installation instructions, see pages 58-61 in the Technical Section.

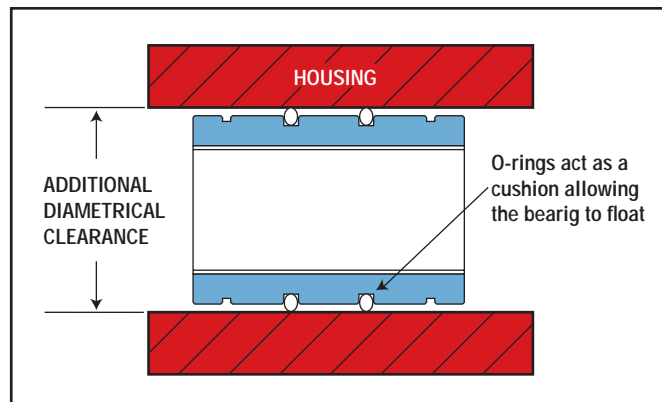

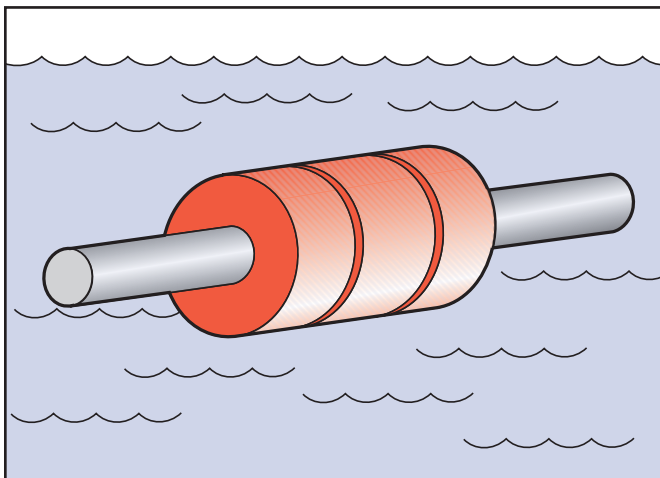
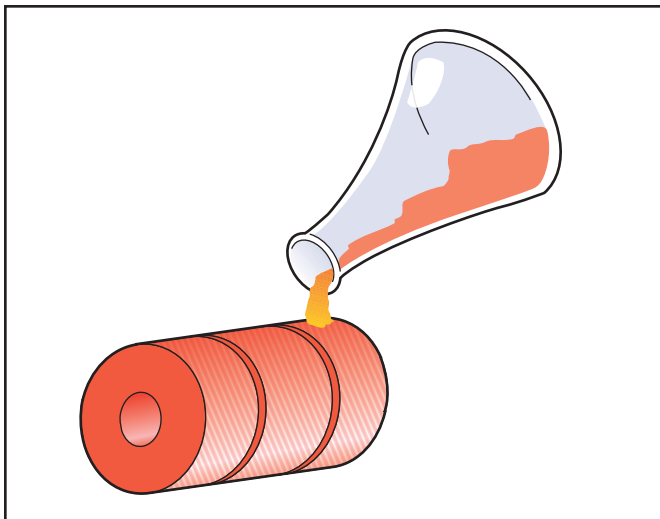

CHEMICAL RESISTANCE

Simplicity bearings stand up to harsh environments.

FrelonJ® – almost universal chemical inertness. Only molten sodium and flourine at elevated temperatures and pressures show any signs of attack.

FrelonGOLD® – the fillers in the material can be attacked by deionized water and other harsh chemicals.

Anodized Aluminum Shell (Standard) – good chemical resistance in most industrial applications.

316 Stainless Steel Shell (Optional) – excellent chemical and corrosion resistance in harsh environments. (See page 62 for complete chemical interaction listing.)

SUBMERGED APPLICATIONS

Simplicity bearings will provide excellent performance in a submerged condition.

The bearings will employ the fluid as a lubricant showing increased velocities and wear life. Oils and non-salt water are especially effective.

Do not use FrelonGOLD® in submerged applications, however FrelonGOLD® is suitable for washdowns.

VACUUMS/OUTGASSING/CLEAN ROOMS

Due to self-lubrication, low outgassing, and a minimum of particulate (buildup), Simplicity bearings are excellent in clean rooms and vacuums.

Testing has been done on the Frelon® materials in accordance with ASTM E-595-90 with acceptable maximums of 1.00% TML and .10% CVCM.

MATERIAL	% TML	% CVCM
Frelon	0.00	0.00
FrelonJ	0.18	0.01

TML = Total Mass Loss

CVCM = Collected Volatile Condensable Materials

The data and specifications in this publication have been carefully compiled and are believed to be accurate and correct. However, it is the responsibility of the user to determine and ensure the suitability of Pacific Bearing® products for a specific application. Pacific Bearing's only obligation will be to repair or replace without charge, any defective components if returned promptly. No liability is assumed beyond such replacement. *Consult www.pacific-bearing.com for the latest technical updates.



CLASSES OF PLANE BEARINGS

Simplicity bearings are in a class of bearings known as plane bearings, which means that they have no rolling elements. There are three classes of plane bearings:

Class I - Require an outside source of lubrication (oil, grease, etc.).

Class II - Lubrication is impregnated within the walls of the bearing. (Bronze, powder metal, etc.) Typically these bearings require an added lubricant also.

Class III - Self-lubricating bearings, which do not require added lubricants.

Simplicity bearings are Class III plane bearings and are self-lubricating.

RATING A PLANE BEARING

Plane bearing performance capacity is rated by PV.

P - pressure or load in pounds per square inch (psi) or kilograms per square centimeter (kg/cm²).

V - velocity or surface speed in feet per minute (fpm or sfm) or meters per minute (m/min.).

PV - pressure velocity value.

SIMPLICITY MAXIMUM PERIMETER

MAXIMUM PARAMETERS	P	V (RUNNING DRY)	PV
FrelonJ®	1500 psi or 105.45 kgf/cm ²	140 sfm or 42.67 m/min.	10,000 psi x ft./min. or 215 kgf/cm ² x m/min.
FrelonGOLD®	3000 psi or 210.9 kgf/cm ²	300 sfm or 91.44 m/min.	20,000 psi x ft./min. or 430 kgf/cm ² x m/min.

NOTE: All three parameters must be met in order for the bearing to operate properly.

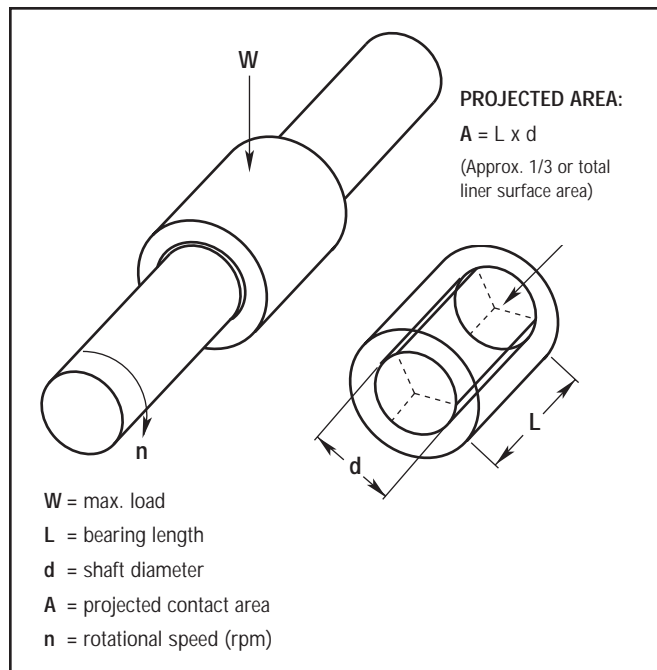

FORMULAS FOR RATINGS

PRESSURE IS OVER THE PROJECTED AREA OF LOAD:

$$A = L \times d$$

$$P = \frac{W}{A} \text{ psi (or kg/cm}^2\text{)}$$

VELOCITY:

Linear = total distance traveled in one minute

ROTATIONAL VELOCITY:

$$V = \frac{\pi \times d \times n}{12} \text{ fpm (or m/min.)}$$

PRESSURE VELOCITY VALUE (PV):

$$PV = P \times V \text{ psi x fpm (or kg/cm}^2 \text{ x m/min.)}$$

PV EQUIVALENTS

	INCH	TECHNICAL METRIC	INT'L METRIC (SI)
LOAD	1 psi	.0703 kgf/cm ²	.0069 N/mm ²
VELOCITY	1 ft./min.	.3048 m/min.	.00508 m/sec.
PV	1 PV	.0214 PV	.000036 PV
FrelonJ® MAX PV	10,000	215	.36
FrelonGOLD® MAX PV	20,000	430	.72

The data and specifications in this publication have been carefully compiled and are believed to be accurate and correct. However, it is the responsibility of the user to determine and ensure the suitability of Pacific Bearing® products for a specific application. Pacific Bearing's only obligation will be to repair or replace without charge, any defective components if returned promptly. No liability is assumed beyond such replacement. *Consult www.pacific-bearing.com for the latest technical updates.



WEAR RATE VS. LIFE EXPECTANCY

A rolling element linear bearing's life expectancy is usually expressed in total inches or meters. A rolling element rotary bearing's life expectancy is expressed in hours of operation. Both are also rated for average (L-50) and minimum (L-10) life. L-50 life is the average life that can be expected from 50% of rolling element bearings. In other words, 50% will not reach the average life expectancy. L-10 life is the minimum life (1/5 the average life) expected from 90% of rolling element bearings. In other words, 10% will not reach the minimum life expectancy. Theoretically they could fail upon installation.

Plane bearings are not rated by a life expectancy but by the wear rate of the bearing material. Wear is greatly dependent

upon the proper application of the bearing and material used. If it is not properly applied, it will fail. Failure, however, is subjective and dependent upon specific application requirements. 0.002" running clearance may not be acceptable in one application while another may be able to run a bearing until the liner is completely worn through. The user may then rotate it 30 degrees and continue to run it. This broad range of acceptability makes it difficult to determine life expectancy.

The first step is to determine what wear is acceptable for your application. Then utilizing the test data below, you can estimate the wear expected for your given application.

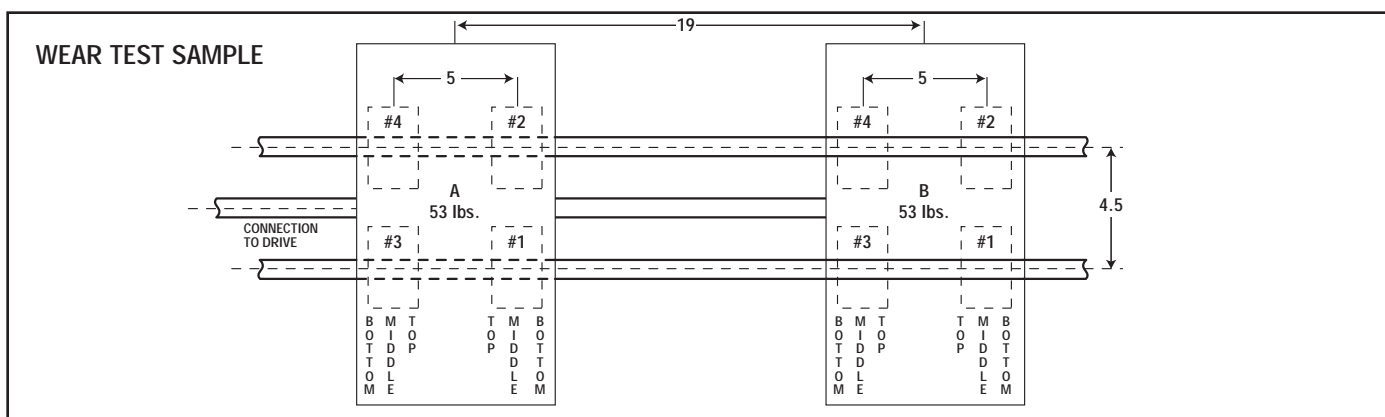

CONDUCTED BY: Pacific Bearing® Company

BEARING MATERIAL: FrelonGOLD®

SHAFT MATERIAL: Standard RC60 steel shafting

SURFACE FINISH: 8-12 RMS

SPEED: 140 fpm (70 cycles/min; 1,680"/min; 100,800"/hour; 2,419,200"/day)

STROKE: 12"

LOAD: 10.87 psi (53 lbs.)

BEARINGS USED: FLN12 (3/4" open style bearings)

LUBRICATION: None

TOTAL WEAR TO BEARING MATERIAL:
FrelonGOLD® = .00042"

NOTE: Wear is an average of totals taken from 4 bearings per carriage.

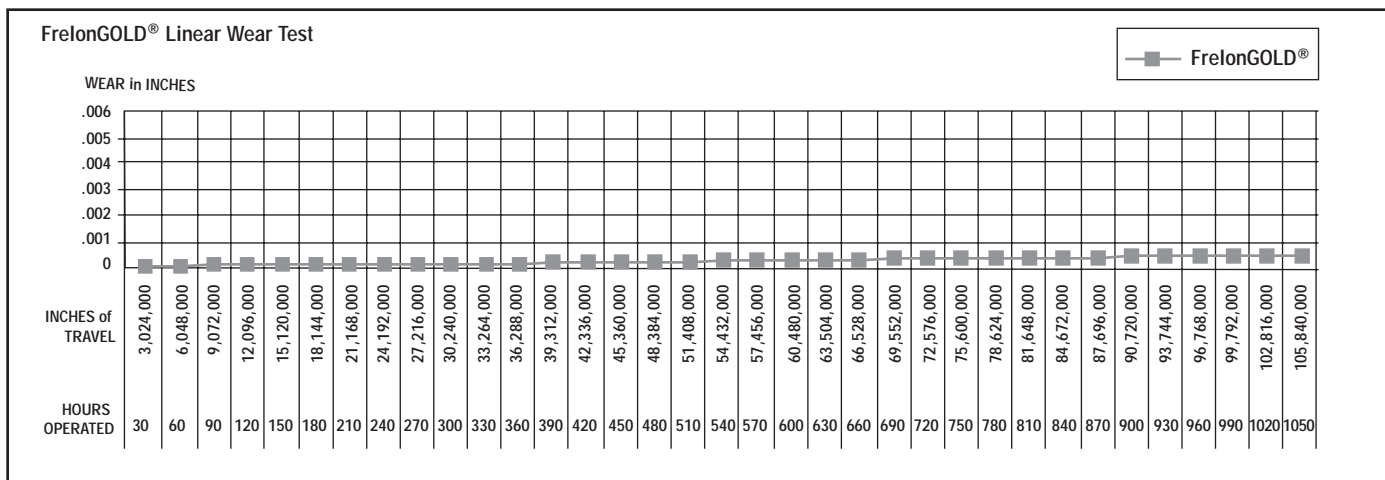

The data and specifications in this publication have been carefully compiled and are believed to be accurate and correct. However, it is the responsibility of the user to determine and ensure the suitability of Pacific Bearing® products for a specific application. Pacific Bearing's only obligation will be to repair or replace without charge, any defective components if returned promptly. No liability is assumed beyond such replacement. *Consult www.pacific-bearing.com for the latest technical updates.



COEFFICIENT OF FRICTION

A frequent misconception of plane bearings is that wear and friction are basically synonymous, in that, high friction equals high wear or that low friction equals low wear. While there can be a relation between the two, they should be addressed as separate issues in the design process.

For example, dry running virgin (unfilled) Teflon® on steel's coefficient of friction (c.o.f.) is approximately .1 while filled Teflon's c.o.f. can range from .125 to .4 depending on the fillers used. By comparison, however, the virgin Teflon will wear at a much greater rate.

FRICION TEST SAMPLE #1

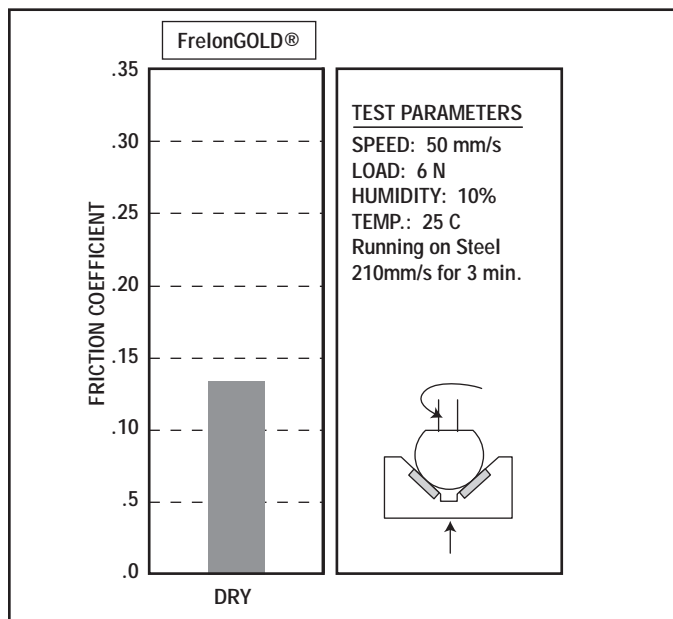

CONDUCTED BY: Dr. Tillwich GmbH

MANAGING DIRECTOR: Mr. Werner Stehr (World leading tribologist with a seat on the ISOTC123 Committee establishing standards for tribological testing.)

BEARING MATERIAL: FrelonGOLD®

SHAFT MATERIAL: Standard RC60 steel shafting

SURFACE FINISH: 8-12 RMS

SPEED: 50 mm/sec

LOAD: 6 N

TEMP.: 25° C

LUBRICATION: None

AVG. COEFFICIENT OF FRICTION:
 FrelonGOLD® = .125

FRICION TEST SAMPLE #2

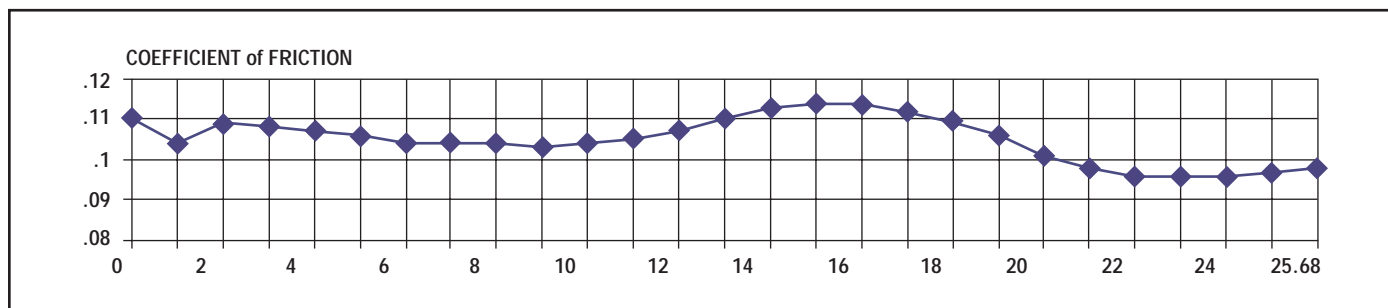

CONDUCTED BY: FrelonGOLD® material processor

BEARING MATERIAL: FrelonGOLD®

SHAFT MATERIAL: CRS 1018

SPEED: 100 fpm

LOAD: 100 psi

DURATION: 25.68 hours

LUBRICATION: None

SURFACE FINISH: 8 RMS

AVERAGE COF: 0.10

MAX. COF: 0.15

MIN. COF: 0.08

AVG. RUNNING TEMP.: 95.40° F

The data and specifications in this publication have been carefully compiled and are believed to be accurate and correct. However, it is the responsibility of the user to determine and ensure the suitability of Pacific Bearing® products for a specific application. Pacific Bearing's only obligation will be to repair or replace without charge, any defective components if returned promptly. No liability is assumed beyond such replacement. *Consult www.pacific-bearing.com for the latest technical updates.



LOAD CAPACITY (Pressure)

Depending upon the material used, a plane bearing's load capacity can greatly exceed a rolling element bearing. There are three basic reasons for this:

1. The area of surface contact with the shaft is far greater than rolling element bearings, which have point-to-point contact with a given number of balls.
2. A rolling element bearing must be oriented properly for the ball tracks to carry the load adequately, while a plane bearing can be mounted in any orientation.
3. Only one or two of the tracks in a rolling element bearing will actually carry any of the load applied.

Simplicity bearings have a thin liner that is bonded to a metal shell at the molecular level, allowing the load to be transferred throughout the bearing. This gives it an advantage over other plane bearings of solid plastic or polymer materials. These other materials will tend to "cold flow" under pressure. "Cold flow" means to deform or lose shape. The idea is similar to pressing your finger into a bar of soap - material will move or deform as pressure is applied.

LINEAR SURFACE SPEEDS (Velocity)

In typical applications, speed is a known quantity and easily converted. Typically feet per minute or meters per minute are used. The most important factor that speed (along with friction) produces is heat buildup. This is not a critical factor in most linear applications because the heat is dissipated over the length of travel, and it does not affect the bearing. Short stroke or extremely high speed applications may see the effects of heat buildup in thermal expansion and the bearing ID locking on the shaft. A compensated ID bearing (FLC) is recommended in these applications.

FACTORS THAT CONTRIBUTE TO WEAR LIFE

Proper mating of shaft and liner materials.

Surface finish 8-16 RMS (.20-.40mm) is required. Peaks in the surface that are polished to a radius provide the best running surface. Sharp peaks in the finish will be like a fine lapping compound wearing the I.D. of the bearing.

NOTE: Shafting damaged by use with ball bearings can be salvaged and used with Simplicity bearings. Spin in a lathe and polish with sand papers in this order: 120 grit, 180 grit, and 300 grit. This will also remove sharp peaks in the surface finish.

Surface speed - at high speeds, heat buildup will affect liner wear.

Break-in transfer - proper transfer process of the liner to the shaft. (pg. 46)

Lubrication - proper lubrication can greatly improve the wear rate of a bearing. At the same time, improper lubrication can increase wear and failure.

Load & Wear Relationship - Wear is proportional to $(load)^3$, so if load is reduced to $1/2$, wear will be reduced to $(1/2)^3$.

Contamination - while migrating into the bearing and embedding into the liner, certain types of contamination may, over time, cause increased wear to the liner.

NOTE: This is not an all inclusive list. There are many, many more factors within an application that can affect wear to different degrees. These are the major issues and the first things to address in a design.

TYPES AND EFFECTS OF LUBRICATION

Lubrication is any outside technique used for reducing the friction, wear, or both of a bearing. **Proper lubrication of Simplicity bearings is critical.** Evaluate lubrication needs on an application by application basis to determine whether or not it should be used at all, what type is needed, and how it is applied. Below are some criteria on which to base the lubricant decision:

DO NOT USE WD40™, PTFE sprays, or other oils, greases, or sprays that contain fluorocarbons or silicone. In testing, these lubricants have proven to cause long-term stick-slip problems with the Frelon lined bearings. They tend to become a gummy substance that ultimately increases friction.

RECOMMENDED LUBRICANTS:

- Waylube oils
- Lightweight oils
- 3-in-1 type oils
- Lightweight petroleum based greases

WD40™ is a registered trademark of the WD40 Corporation.



USING OILS WITH SIMPLICITY

DO NOT USE ANY TYPE OF MOTOR OIL OR OILS WITH ADDITIVES! These types of oils work well short term, but quickly become ineffective, and will cause stick-slip reactions in the bearing. As a rule of thumb, the less additives in the oil, the better the performance. Recommended oils are Mobil Vactra #2 (a way lube oil) and any standard 3-in-1 oil. The 3-in-1 oils are tremendous cleaning oils and are the best in preparing for a proper transfer of teflon to the shafting.

GREASE PRODUCTS

DO NOT USE A MOLY FILLED OR OTHER TYPE FILLED GREASES! They become like a lapping compound on the ID of the bearing and increase wear dramatically.

PROPER USE OF GREASES

Proper use of grease is critical for trouble-free operation.

Be sure the felt wick is removed from a “FL-xx-JKM” bearing because grease inserted through the zerk will cause the wick to act like a brake.

Do not fill all of the running clearance with grease! The temptation is to treat it like a rolling element bearing and fill it until it weeps from the end. This will cause greater friction and binding.

The rule of thumb for the bearing liner that “thin is better” applies to the use of grease also.

If grease is used and does not work in the application, it is possible to salvage the bearing with minimal work and to continue to operate. Follow the steps below:

1. If possible, remove the bearing from the housing, wipe the grease from the liner, use a 3-in-1 type oil to clean the excess remaining grease, and reinstall.
2. If it is not possible to remove the bearing, wipe as much grease as possible away from the ends of the bearing, then start to fill with a 3-in-1 type oil for cleaning the liner. To speed the cleaning process, apply forced air to the bearing through the zerk hole and continue using oil lubrication.

EFFECTS OF LUBRICATION

Lubrication can greatly increase the performance of a bearing when applied properly as noted earlier. Actual performance results for specific applications are difficult to predict due to the number of elements involved (temperature change with lube, useable life or aging of lubricant, etc.). Specific application testing is recommended to establish specific performance parameters. Below are charts with guidelines of performances.



APPLICATION INFORMATION

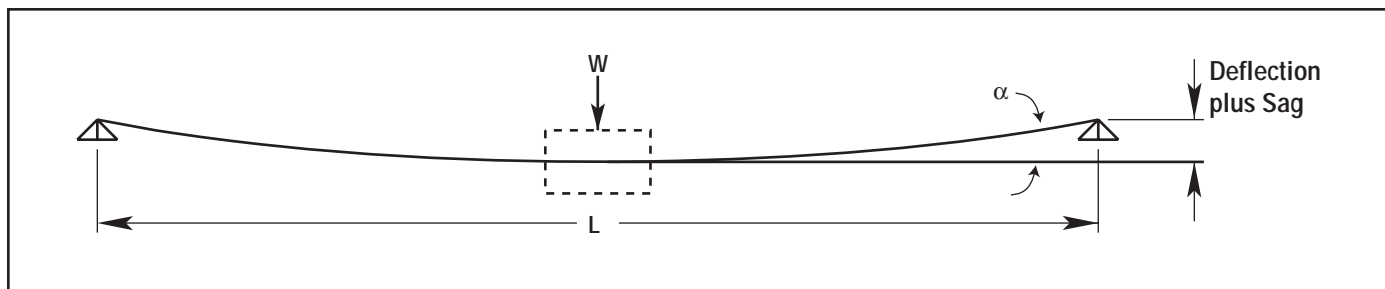

INCH

SHAFT DIAMETER	HARDENED STEEL		STAINLESS STEEL		FEATHER® SHAFT	
	D	S	D	S	D	S
3/16"	8.4×10^4	1.7×10^7	8.0×10^4	1.6×10^7	2.9×10^4	$1.65E+05$
1/4"	2.67×10^5	3.1×10^7	2.54×10^5	2.9×10^7	9.2×10^4	$2.93E+05$
3/8"	1.35×10^6	6.9×10^7	1.29×10^6	6.5×10^7	4.7×10^5	$6.58E+05$
1/2"	4.27×10^6	1.23×10^8	4.06×10^6	1.16×10^8	1.5×10^6	$1.17E+06$
5/8"	1.04×10^7	1.92×10^8	9.92×10^6	1.81×10^8	3.6×10^6	$1.83E+06$
3/4"	2.16×10^7	2.77×10^8	2.06×10^7	2.61×10^8	7.5×10^6	$2.63E+06$
1"	6.83×10^7	4.92×10^8	6.5×10^7	4.63×10^8	2.4×10^7	$4.68E+06$
1-1/4"	1.67×10^8	7.69×10^8	1.59×10^8	7.24×10^8	5.8×10^7	$7.31E+06$
1-1/2"	3.46×10^8	1.11×10^9	3.29×10^8	1.04×10^9	1.22×10^8	$1.05E+07$
2"	1.09×10^8	1.97×10^9	1.04×10^9	1.85×10^9	3.8×10^8	$1.87E+07$
2-1/2"	2.67×10^8	3.07×10^9	2.54×10^9	2.9×10^9	N/A	N/A
3"	5.53×10^9	4.43×10^9	5.27×10^9	4.17×10^9	N/A	N/A
4"	1.75×10^{10}	7.87×10^9	1.66×10^{10}	7.41×10^9	N/A	N/A

METRIC

SHAFT DIAMETER	HARDENED STEEL		STAINLESS STEEL	
	D	S	D	S
5 mm	2.94×10^8	3.12×10^{11}	2.8×10^8	2.94×10^{11}
6 mm	6.11×10^8	4.5×10^{11}	5.81×10^8	4.24×10^{11}
8 mm	1.93×10^9	8.0×10^{11}	1.84×10^9	7.53×10^{11}
10 mm	4.71×10^9	1.25×10^{12}	4.48×10^9	1.18×10^{12}
12 mm	9.77×10^9	1.8×10^{12}	9.3×10^9	1.69×10^{12}
13 mm	1.35×10^{11}	2.11×10^{12}	1.28×10^{11}	1.99×10^{12}
14 mm	1.81×10^{10}	2.45×10^{12}	1.72×10^{11}	2.31×10^{12}
16 mm	3.09×10^{10}	3.2×10^{12}	2.94×10^{11}	3.01×10^{12}
20 mm	7.54×10^{10}	5.0×10^{12}	7.17×10^{11}	4.71×10^{12}
25 mm	1.84×10^{11}	7.81×10^{12}	1.75×10^{11}	7.35×10^{12}
30 mm	3.82×10^{11}	1.12×10^{13}	3.63×10^{11}	1.06×10^{13}
35 mm	7.07×10^{11}	1.53×10^{13}	6.73×10^{11}	1.44×10^{13}
38 mm	9.82×10^{11}	1.8×10^{13}	9.35×10^{11}	1.7×10^{13}

The data and specifications in this publication have been carefully compiled and are believed to be accurate and correct. However, it is the responsibility of the user to determine and ensure the suitability of Pacific Bearing® products for a specific application. Pacific Bearing's only obligation will be to repair or replace without charge, any defective components if returned promptly. No liability is assumed beyond such replacement. *Consult www.pacific-bearing.com for the latest technical updates.



SHAFT DEFLECTION

In applications where a support rail is not used, shaft deflection can become critical in the function of the bearing. If deflection is greater than the misalignment capabilities of a standard pillow block, binding can occur. Solutions would be to increase shaft and bearing size (to lessen the amount of deflection) or to use an open bearing configuration with a support rail. Follow the formulas below to check shaft deflection and sag.

FORMULA FOR INCH AND METRIC SHAFTING DEFLECTION

Total shaft deflection in horizontal applications:

$$\text{Tot. Def} = \text{Def} + \text{Sag}$$

$$\text{Def} = w \times L^3 / D$$

$$\text{Sag} = L^4 / S$$

Def = Pure deflection due to load at center of shaft (inches or mm)

Sag = Deflection of shaft due to its own weight (inches or mm)

L = Shaft unsupported length (inches or mm)

w = load being applied at center of shaft (lbs. or N)

D = Deflection coefficient (D = 48 x E x I)

S = Sag coefficient (S = E x I x 384 / (5 x sw))

NOTES: I = $\pi \times \text{diam}^4 / 64$

sw = $\pi \times \text{diam}^2 / 4 \times \text{density}$

E = Modulus of Elasticity (Young's modulus)

TOTAL DEFLECTION

ø1 in. Shaft

24 in. Length (L)

250 lbs. load (W)

$$\begin{aligned} \text{Deflection} &= \frac{W \times L^3}{D \text{ (from table)}} \\ &= \frac{250 \text{ lbs.} \times (24 \text{ in.})^3}{6.83 \times 10^7} \\ &= \frac{3,456,000 \text{ in.}^3 \text{ lbs.}}{68,300,000 \text{ in.}^2 \text{ lbs.}} \end{aligned}$$

$$\text{Deflection} = 0.0506 \text{ in.}$$

$$\begin{aligned} \text{SAG} &= \frac{L^4}{S \text{ (from table)}} \\ &= \frac{(24)^4}{4.92 \times 10^8} \end{aligned}$$

$$\text{SAG} = \frac{331,776 \text{ in.}^4}{492,000,000 \text{ in.}^3}$$

$$\text{SAG} = .000674 \text{ in.}$$

$$\begin{aligned} \text{Total Deflection} &= \text{Deflection} + \text{SAG} \\ &= 0.0506 \text{ in.} + .000674 \text{ in.} \end{aligned}$$

$$\text{Total Deflection} = 0.0513 \text{ in.}$$

DISPLACEMENT ANGLE

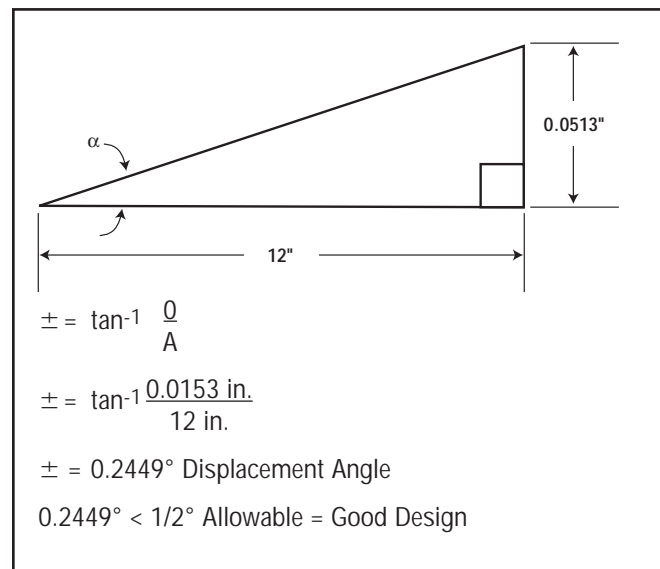

The data and specifications in this publication have been carefully compiled and are believed to be accurate and correct. However, it is the responsibility of the user to determine and ensure the suitability of Pacific Bearing® products for a specific application. Pacific Bearing's only obligation will be to repair or replace without charge, any defective components if returned promptly. No liability is assumed beyond such replacement. *Consult www.pacific-bearing.com for the latest technical updates.



INSTALLING SIMPLICITY® BEARINGS

Applies to standard linear bearing series.

For sleeve and flange bearings, see product pages in the catalog.

PS - Page 154, PSM - Page 156, PSF - Page 155, PSFM - Page 157

STRAIGHT BORE HOUSING - PRESS FIT BEARING

This type of configuration is NOT recommended for the vast majority of applications using Simplicity bearings.

It does NOT allow for any misalignment or shaft deflection.

Misalignment or shaft deflection will cause the bearing to bind on the shafting.

Extremely high precision applications may be able to employ this type of mounting. Typically the shafting has been aligned with a laser or some other highly precise equipment.

Due to bore closure in the pressing process, use a "C" series (compensated I.D.) bearing.

EXAMPLE: FLC24, FMC30, FJC30

The recommended installation procedure is to freeze the bearings at 0°F (-17.75°C) for 30-45 minutes. Using gloves, remove the bearings from the freezer and slip them into the housing. As they heat to room temperature, full contact between bearing and housing will be achieved. The greatest advantage to this technique over traditional pressing is greater accuracy in alignment.

This type of mounting will not allow for misalignment or shaft deflection. Both are very critical in the smooth operation of Simplicity bearings. A rolling element bearing may appear to initially operate in this condition, but it is operating in an extremely preloaded condition and will prematurely fail and in most cases destroy the shafting. Simplicity bearings will indicate the problem immediately upon installation by failing to move due to the binding condition. There are alternative mounting options that work extremely well.

PART NO.	MIN. HOUSING I.D.	MAX. HOUSING I.D.	PART NO.	MIN. HOUSING I.D.	MAX. HOUSING I.D.	PART NO.	MIN. HOUSING I.D.	MAX. HOUSING I.D.	PART NO.	MIN. HOUSING I.D.	MAX. HOUSING I.D.	PART NO.	MIN. HOUSING I.D.	MAX. HOUSING I.D.
	(inches)	(inches)		(mm)	(mm)		(mm)	(mm)		(mm)	(mm)		(mm)	(mm)
FLC03	0.3729	0.3737	FMC05	11.972	11.995	FMTC06	11.954	11.972	FGC06	11.952	11.970	FJC06	11.961	11.979
FLC04	0.4978	0.4986	FMC08	15.954	15.972	FMTC08	14.954	14.972	FGC08	14.952	14.970	FJHC08	14.961	14.979
FLC06	0.6228	0.6236	FMC10	18.948	18.969	FMTC10	16.954	16.972	FGC10	16.952	16.970	FJC08	14.961	14.979
FLC08	0.8725	0.8734	FMC12	21.944	21.965	FMTC12	18.948	18.969	FGC12	21.945	21.966	FJC10	18.952	18.973
FLC10	1.1224	1.1234	FMC16	25.944	25.965	FMTC14	20.944	20.965	FGC15	24.945	24.966	FJC12	20.952	20.997
FLC12	1.2474	1.2484	FMC20	31.940	31.961	FMTC16	23.944	23.965	FGC16	25.945	25.966	FJC13	22.952	22.973
FLC16	1.5596	1.5607	FMC25	39.932	39.957	FMTC20	27.944	27.965	FGC18	27.945	27.966	FJC16	27.952	27.973
FLC20	1.9970	1.9981	FMC30	46.932	46.957	FMTC25	34.940	34.961	FGC20	31.945	31.966	FJC20	31.950	31.971
FLC24	2.3717	2.3729	FMC40	61.917	61.947	FMTC30	39.932	39.957	FGC25	39.937	39.962	FJC25	39.941	39.966
FLC32	2.9965	2.9977	FMC50	74.917	74.947	FMTC40	51.932	51.957	FGC30	44.937	44.962	FJC30	44.941	44.966
FLC40	3.7461	3.7473	FMC60	89.906	89.936	FMTC50	61.917	61.947	FGC35	51.937	51.962	FJC35	51.938	51.963
FLC48	4.4953	4.4966	FMC80	119.886	119.921				FGC40	59.927	59.957	FJC38	56.938	56.963
FLC64	5.9949	5.9963							FGC50	74.927	74.957	FJC40	59.928	59.958
												FJC50	79.922	79.952
												FJC60	89.919	89.949
												FJC80	119.899	119.934
												FJC100	149.896	149.931
												FJC120	179.875	179.915
												FJC150	209.849	209.895

NOTE: Use "C" (compensated I.D.) series bearings.

The data and specifications in this publication have been carefully compiled and are believed to be accurate and correct. However, it is the responsibility of the user to determine and ensure the suitability of Pacific Bearing® products for a specific application. Pacific Bearing's only obligation will be to repair or replace without charge, any defective components if returned promptly. No liability is assumed beyond such replacement. *Consult www.pacific-bearing.com for the latest technical updates.



INSTALLING SIMPLICITY® BEARINGS

STRAIGHT BORE HOUSING - SLIP FIT BEARING

There are three basic configurations that work well, depending on the misalignment and shaft deflection in the application:

1. Virtually NO misalignment

This method allows for NO or very little shaft deflection and misalignment.

Standard I.D. bearings will need tighter alignment than a "C" series (compensated I.D.) bearing.

Standard retention methods are acceptable.

EXAMPLE: snap rings, epoxy, etc.

NOTE: If using epoxy, do not touch the bearing liner with the bonding agent!

This type of mounting will allow for minimum misalignment or shaft deflection. Both are very critical in the smooth operation of Simplicity bearings. A rolling element bearing may appear to initially operate in this condition, but it is operating in an extremely preloaded condition and will prematurely fail and in most cases destroy the shafting. Simplicity bearings will indicate the problem immediately upon installation by failing to move due to the binding condition.

PART NO.	MIN. HOUSING I.D.	MAX. HOUSING I.D.	PART NO.	MIN. HOUSING I.D.	MAX. HOUSING I.D.	PART NO.	MIN. HOUSING I.D.	MAX. HOUSING I.D.	PART NO.	MIN. HOUSING I.D.	MAX. HOUSING I.D.	PART NO.	MIN. HOUSING I.D.	MAX. HOUSING I.D.
	(inches)	(inches)		(mm)	(mm)		(mm)	(mm)		(mm)	(mm)		(mm)	(mm)
FL03	0.3755	0.3764	FM05	12.016	12.043	FMT06	12.016	12.043	FG06	12.016	12.043	FJ06	12.016	12.043
FL04	0.5006	0.5017	FM08	16.016	16.043	FMT08	15.016	15.043	FG08	15.016	15.043	FJH08	15.016	15.043
FL06	0.6256	0.6267	FM10	19.020	19.053	FMT10	17.016	17.043	FG10	17.016	17.043	FJ08	15.016	15.043
FL08	0.8758	0.8771	FM12	22.020	22.053	FMT12	19.020	19.053	FG12	22.020	22.053	FJ10	19.020	19.053
FL10	1.1258	1.1271	FM16	26.020	26.053	FMT14	21.020	21.053	FG15	25.020	25.053	FJ12	21.020	21.053
FL12	1.2510	1.2525	FM20	32.025	32.064	FMT16	24.020	24.053	FG16	26.020	26.053	FJ13	23.020	23.053
FL16	1.5635	1.5650	FM25	40.025	40.064	FMT20	28.020	28.053	FG18	28.020	28.053	FJ16	28.020	28.053
FL20	2.0012	2.0030	FM30	47.025	47.064	FMT25	35.025	35.064	FG20	32.025	32.064	FJ20	32.025	32.064
FL24	2.3762	2.3780	FM40	62.030	60.076	FMT30	40.025	40.064	FG25	40.025	40.064	FJ25	40.025	40.064
FL32	3.0012	3.0030	FM50	75.030	75.076	FMT40	52.030	52.076	FG30	45.025	45.064	FJ30	45.025	45.064
FL40	3.7514	3.7535	FM60	90.036	90.090	FMT50	62.030	62.076	FG35	52.030	52.076	FJ35	52.030	52.076
FL48	4.5014	4.5035	FM80	120.036	120.090				FG40	60.030	60.076	FJ38	57.030	57.076
FL64	6.0017	6.0042							FG50	75.030	75.076	FJ40	60.030	60.076
												FJ50	80.030	80.076
												FJ60	90.036	90.090
												FJ80	120.036	120.090
												FJ100	150.043	150.106
												FJ120	180.043	180.106
												FJ150	210.050	210.122

The data and specifications in this publication have been carefully compiled and are believed to be accurate and correct. However, it is the responsibility of the user to determine and ensure the suitability of Pacific Bearing® products for a specific application. Pacific Bearing's only obligation will be to repair or replace without charge, any defective components if returned promptly. No liability is assumed beyond such replacement. *Consult www.pacific-bearing.com for the latest technical updates.



INSTALLING SIMPLICITY® BEARINGS

STRAIGHT BORE HOUSING - SLIP FIT BEARING (cont.)

2. Standard applications with average misalignment

A self-aligning O.D. bearing is recommended.

EXAMPLE: FLA24, FMA30, FJA30

For details on the self-aligning O.D. feature, see page 41 of the product catalog.

The recommended method of retention for this mounting is a snap ring at each end.

NOTE: Do not use epoxy in this configuration. It will lock the bearing in place not allowing it to self-align.

Be sure to install the o-rings around the O.D. of the bearing to reduce noise while the bearing is in operation.

PART NO.	MIN. HOUSING I.D.	MAX. HOUSING I.D.	PART NO.	MIN. HOUSING I.D.	MAX. HOUSING I.D.	PART NO.	MIN. HOUSING I.D.	MAX. HOUSING I.D.	PART NO.	MIN. HOUSING I.D.	MAX. HOUSING I.D.	PART NO.	MIN. HOUSING I.D.	MAX. HOUSING I.D.
	(Inches)	(Inches)		(mm)	(mm)		(mm)	(mm)		(mm)	(mm)		(mm)	(mm)
FLA03	0.3755	0.3764	FMA05	12.016	12.043	FMT06	N / A	N / A	FG06	N / A	N / A	FJA06	12.016	12.043
FLA04	0.5006	0.5017	FMA08	16.016	16.043	FMT08			FJHA08			15.016	15.043	
FLA06	0.6256	0.6267	FMA10	19.020	19.053	FMT10			FG10			FJA08	15.016	15.043
FLA08	0.8758	0.8771	FMA12	22.020	22.053	FMT12			FG12			FJA10	19.020	19.053
FLA10	1.1258	1.1271	FMA16	26.020	26.053	FMT14			FG15			FJA12	21.020	21.053
FLA12	1.2510	1.2525	FMA20	32.025	32.064	FMT16			FG16			FJA13	23.020	23.053
FLA16	1.5635	1.5650	FMA25	40.025	40.064	FMT20			FG18			FJA16	28.020	28.053
FLA20	2.0012	2.0030	FMA30	47.025	47.064	FMT25			FG20			FJA20	32.025	32.064
FLA24	2.3762	2.3780	FMA40	62.030	60.076	FMT30			FG25			FJA25	40.025	40.064
FLA32	3.0012	3.0030	FMA50	75.030	75.076	FMT40			FG30			FJA30	45.025	45.064
FLA40	3.7514	3.7535	FMA60	90.036	90.090	FMT50			FG35			FJA35	52.030	52.076
FLA48	4.5014	4.5035	FMA80	120.036	120.090				FG40			FJA38	57.030	57.076
FLA64	6.0017	6.0042							FG50			FJA40	60.030	60.076
												FJA50	80.030	80.076
								FJA60	90.036	90.090				
								FJA80	120.036	120.090				
								FJA100	150.043	150.106				
								FJA120	180.043	180.106				
								FJA150	210.050	210.122				

NOTE: FMT and FG series are NOT available with a self-aligning O.D

The data and specifications in this publication have been carefully compiled and are believed to be accurate and correct. However, it is the responsibility of the user to determine and ensure the suitability of Pacific Bearing® products for a specific application. Pacific Bearing's only obligation will be to repair or replace without charge, any defective components if returned promptly. No liability is assumed beyond such replacement. *Consult www.pacific-bearing.com for the latest technical updates.



INSTALLING SIMPLICITY® BEARINGS

STRAIGHT BORE HOUSING - SLIP FIT BEARING (cont.)

3. Severe misalignment

A standard O.D. bearing is recommended.

EXAMPLE: FL24, FM30, FJ30

Oversize the I.D. of the housing and install the bearing with o-rings. This will allow the bearing to “float” in the housing and match the misalignment or non-parallelism of the shafting.

The recommended method of retention for this mounting is a snap ring at each end.

NOTE: Do not use epoxy in this configuration. It will lock the bearing in place, not allowing it to self-align.

See page 50 of the product catalog for more details on this solution.

PART NO.	MAX. ADDITIONAL CLEARANCE	PART NO.	MAX. ADDITIONAL CLEARANCE	PART NO.	MAX. ADDITIONAL CLEARANCE	PART NO.	MAX. ADDITIONAL CLEARANCE	PART NO.	MAX. ADDITIONAL CLEARANCE
	(Inches)		(mm)		(mm)		(mm)		(mm)
FL03	0.0070	FM05	0.203	FMT06	0.203	FG06	0.203	FJ06	0.203
FL04	0.0080	FM08		FMT08		FG08		FJH08	
FL06		FM10		FMT10		FG10		FJ08	
FL08		FM12		FMT12		FG12		FJ10	
FL10	0.0100	FM16	0.254	FMT14	0.254	FG15	0.254	FJ12	0.254
FL12		FM20		FMT16		FG16		FJ13	
FL16	0.0120	FM25	0.305	FMT20	0.305	FG18	0.305	FJ16	0.305
FL20		FM30		FMT25		FG20		FJ20	
FL24		FM40		FMT30		FG25		FJ25	
FL32		FM50	FMT40	FG30	FJ30				
FL40	0.0160	FM60	0.406	FMT50	0.406	FG35	0.406	FJ35	0.406
FL48		FM80		FG40		FJ38			
FL64	0.0200					FG50		FJ40	
								FJ50	0.406
								FJ60	
								FJ80	0.508
								FJ100	0.610
								FJ120	
								FJ150	

The data and specifications in this publication have been carefully compiled and are believed to be accurate and correct. However, it is the responsibility of the user to determine and ensure the suitability of Pacific Bearing® products for a specific application. Pacific Bearing's only obligation will be to repair or replace without charge, any defective components if returned promptly. No liability is assumed beyond such replacement. *Consult www.pacific-bearing.com for the latest technical updates.



CHEMICAL REACTION CHART

The original FrelonJ® has almost universal chemical inertness. Only molten sodium and fluorine at elevated temperatures and pressures show any signs of attack. It is approved for use with liquid oxygen, N₂O₂ hydrazine, UDMH, hydrocarbon fuels, high strength hydrogen peroxide, etc.

The FrelonGOLD® material is a composite of PTFE and a bearing filler. The PTFE is chemically inert. The chemical resistance shown in the chart below is defined by the compatibility of the filler with the various chemicals.

Other data in the chart below applies to the bearing shell and pillow block materials. The table is provided as a reference only. The data given will be affected by factors such as temperature, PV, degree of contact, strength of solution, etc. In each specific application, it is always advisable to conduct specific testing to determine suitability of use. This table only addresses general corrosion, NOT galvanic, SCC, or other types of corrosion. Corrosion rates are at room temperature unless otherwise noted.

Standard and hard coat data only apply when the coating is intact. If the coating is worn through or damaged, an area of galvanic and pitting corrosion will be created. Then use the bare aluminum data.

Standard Simplicity products use aluminum alloy, which is known to have the best corrosion resistance of the high strength aluminum alloys. The sulfuric bath anodizing and nickel acetate sealing provide the best corrosion resistance available in anodized coatings. They can withstand a rigorous 14-day exposure in a 5% salt spray solution at 96°F per military specifications without significant damage. With the coating intact, it is considered to be inert in most fluids with a pH value between 5 and 8. Hard coat anodizing provides the same chemical resistance but is applied to a .002" thickness, providing a more durable surface that will stand up to greater abuse. However, if the coating is penetrated, the resistance is reduced.

Special stainless steel bearings use AISI 316 stainless, which has superior resistance over 303, 304, 420, 440, 17-4PH, and most other common stainless grades. 316 is generally considered to be the most corrosion resistant of conventional stainless steels.

NOTE: This information was compiled for Pacific Bearing® Company by Materials Engineering, Inc. of Virgil, IL. This specification information is believed to be accurate and reliable, however, no liability is assumed. INFORMATION IS FOR REFERENCE ONLY. USER MUST TEST SPECIFIC APPLICATIONS.

E = < .002" per year

G = < .020" per year

S = < .050" per year

U = > .050" per year

CHEMICAL	E = < .002" per year				G = < .020" per year				S = < .050" per year				U = > .050" per year			
	FRELONGOLD®	BARE ALUMINUM	STANDARD & HARD COAT ANODIZED ALUMINUM	316 STAINLESS STEEL	FRELONGOLD®	BARE ALUMINUM	STANDARD & HARD COAT ANODIZED ALUMINUM	316 STAINLESS STEEL	FRELONGOLD®	BARE ALUMINUM	STANDARD & HARD COAT ANODIZED ALUMINUM	316 STAINLESS STEEL	FRELONGOLD®	BARE ALUMINUM	STANDARD & HARD COAT ANODIZED ALUMINUM	316 STAINLESS STEEL
Acetic Acid, 20%	U	G	G	E	Hydrogen sulfide, dry	U	G	E	E							
Acetone	G	E	E	E	JP-4	G	G	G	G							
Ammonia, anhydrous	G	E	E	E	Kerosene	G	G	G	G							
Ammonium hydroxide, 10%	U	U	U	E	Lactic acid, 10%	G	G	G	E							
Ammonium chloride, 10%	U	U	U	G	Magnesium chloride, 50%	G	U	U	G							
Ammyl acetate (122°F / 50°C)	G	E	E	E	Mercury	U	U	U	E							
Barium hydroxide	U	U	U	G	Methyl alcohol	G	G	G	G							
Beer	G	E	E	E	Methyl ethyl ketone	G	G	G	G							
Boric acid solutions	G	E	E	G	Methylene chloride	G	E	E	G							
Butane	G	G	G	G	Mineral oil	G	G	G	G							
Calcium chloride, 20%	G	G	G	G	Naptha	G	G	G	G							
Calcium hydroxide, 10%	G	G	G	G	Nitric acid, 70%	U	U	U	E							
Carbon dioxide	G	E	E	G	Phosphoric acid, 10%	U	U	U	E							
Carbon monoxide	G	E	E	E	Sodium chloride	G	U	U	E							
Chlorine gas, dry	G	G	G	G	Sodium hydroxide, 20%	G	U	U	G							
Chlorine gas, wet	U	U	U	U	Sodium hypochlorite, 20%	U	G	G	U							
Chromic acid, 10%	U	G	E	E	Sodium peroxide, 10%	U	G	G	G							
Citric acid, 5%	G	E	E	E	Steam (see water)	-	-	-	-							
Ethyl acetate	G	E	E	G	Sulfur dioxide, wet	U	U	U	G							
Ethyl alcohol	G	E	E	G	Sulfur dioxide, dry	G	G	G	G							
Ethylene glycol	G	E	E	G	Sulfur trioxide	U	G	G	G							
Ferric chloride, 50%	U	U	U	U	Sulfuric acid, 50%	U	U	U	U							
Formic acid - Anhydrous	U	E	E	E	Sulfurous acid	U	G	G	E							
Gasoline, Unleaded	G	G	G	G	Toluene (122°F / 50°C)	G	E	E	E							
Hydrochloric acid, 20%	U	U	U	U	Turpentine	G	G	E	E							
Hydrochloric acid, 35%	U	U	U	U	Water, demineralized	U	G	E	E							
Hydrocyanic acid, 10%	U	G	G	G	Water, distilled	G	U	S	G							
Hydrofluoric acid - dilute	U	U	U	U	Sea Water	G	G	E	G							
Hydrofluoric acid, 48%	I	U	U	U	Water, sewage	G	U	S	G							
Hydrogen	G	E	E	E	Xylene	G	G	G	G							
Hydrogen peroxide - dilute	U	E	E	G	Zinc chloride solutions	U	U	U	G							

The data and specifications in this publication have been carefully compiled and are believed to be accurate and correct. However, it is the responsibility of the user to determine and ensure the suitability of Pacific Bearing® products for a specific application. Pacific Bearing's only obligation will be to repair or replace without charge, any defective components if returned promptly. No liability is assumed beyond such replacement. *Consult www.pacific-bearing.com for the latest technical updates.



RC60 STEEL SHAFTING

- RC60 case hardened steel
- Polished for optimum surface finish



SMALL DIAMETER RC60 STEEL SHAFTING*

PART NUMBER	NOMINAL SIZE (inches)	DIAMETER TOLERANCE CLASS "L"		MAX. LENGTH (in.)	HARDNESS DEPTH (MIN.)	WEIGHT PER INCH (lbs.)
		MIN.	MAX.			
NIL02-xx	1/8"	0.1248	0.1247	252	N / A	0.004
NIL03-xx	3/16"	0.1873	0.1872	252	N / A	0.008
NIL04-xx	1/4"	0.2498	0.2497	252	N / A	0.014
NIL06-xx	3/8"	0.2490	0.2495	252	0.040	0.031

RC60 STEEL SHAFTING*

PART NUMBER	NOMINAL SIZE (inches)	DIAMETER TOLERANCE CLASS "L"		MAX. LENGTH (in.)	HARDNESS DEPTH (MIN.)	WEIGHT PER INCH (lbs.)
		MIN.	MAX.			
NIL02-xx	1/8"	0.1248	0.1247	252	N / A	0.004
NIL03-xx	3/16"	0.1873	0.1872	252	N / A	0.008
NIL04-xx	1/4"	0.1865	0.1870	252	N / A	0.014
NIL06-xx	3/8"	0.2490	0.2495	252	0.040	0.031
NIL08-xx	1/2"	0.4990	0.4995	180	0.060	0.055
NIL10-xx	5/8"	0.6240	0.6245	180	0.060	0.086
NIL12-xx	3/4"	0.7490	0.7495	180	0.060	0.125
NIL16-xx	1"	0.9990	0.9995	204	0.080	0.222
NIL20-xx	1-1/4"	1.2490	1.2495	204	0.080	0.348
NIL24-xx	1-1/2"	1.4989	1.4994	204	0.080	0.500
NIL32-xx	2"	1.9987	1.9994	204	0.100	0.890
NIL40-xx	2-1/2"	2.4985	2.4993	204	0.100	1.391
NIL48-xx	3"	2.9983	2.9992	204	0.100	2.003
NIL64-xx	4"	3.9976	3.9988	204	0.100	3.560

*NOTES: Specify length in part number using inches.
 Example: for 1/2" shafting total length 15" = NIL08-15
 Surface finish 8 Ra Max.
 Surface finish 4 Ra Max. - Instrument Shafting

COMPLETE PRODUCT OFFERING

- RC60 Steel
- 440 Stainless Steel
- End Blocks
- Cut-to-Length
- Joinable for longer lengths
- Custom Options
- Support Rails
- Random Lengths
- Pre-drilled and Tapped Shafting

- Suitable for Simplicity® bearings and linear ball bearings
- Available cut-to-length or in full random lengths

PRE-DRILLED & TAPPED RC60 STEEL SHAFTING*

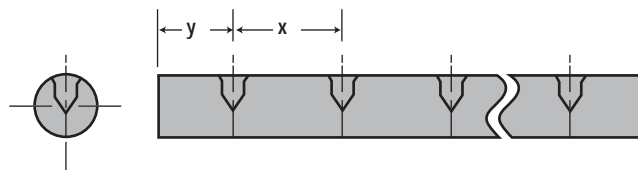

PART NUMBER	NOMINAL SIZE (inches)	DIAMETER TOLERANCE CLASS "L"		HOLE SPACING		THREAD	MAX. LENGTH (in.)	WEIGHT PER INCH (lbs.)
		MIN.	MAX.	x	y			
NIPDL08-xx	1/2"	0.4990	0.4995	4.00	2.00	6-32	156	0.055
NIPDL10-xx	5/8"	0.6240	0.6245			8-32		
NIPDL12-xx	3/4"	0.7490	0.7495	6.00	3.00	10-32	192	0.125
NIPDL16-xx	1"	0.9990	0.9995			1/4-20		
NIPDL20-xx	1-1/4"	1.2490	1.2495	8.00	4.00	5/16-18	192	0.348
NIPDL24-xx	1-1/2"	1.4989	1.4994			3/8-16		
NIPDL32-xx	2"	1.9987	1.9994	8.00	4.00	1/2-13	192	0.890

NOTES: Specify length in part number using inches.
 For random lengths, add "R" to the part number.
 Example: for 1/2" shafting total length 13" = NIPDL08-13
 Customer specifies "y" dimension.

- RC60 Steel Shafting..... 63
- 440 Stainless Steel Shafting..... 64
- Aluminum Pre-drilled Support Rails..... 64
- Aluminum End Support Blocks..... 64
- Aluminum Non-drilled Support Rails..... 65
- Steel Shaft Rail Assembly..... 65
- Feather Shafting®..... 66
- Feather Rails®..... 67
- Inch Self-lubricated Bearings..... 10
- Inch Pillow Blocks..... 12
- Inch Flange Mounted Bearings..... 14-16
- Inch Ball Bearings..... 70
- Inch Ball Bearing Pillow Blocks..... 86
- ISO Metric Shafting..... 68-69

The data and specifications in this publication have been carefully compiled and are believed to be accurate and correct. However, it is the responsibility of the user to determine and ensure the suitability of Pacific Bearing® products for a specific application. Pacific Bearing's only obligation will be to repair or replace without charge, any defective components if returned promptly. No liability is assumed beyond such replacement. *Consult www.pacific-bearing.com for the latest technical updates.



440 STAINLESS STEEL SHAFTING



- 440 Stainless Steel
- Suitable for linear ball bearings
- Available cut-to-length or in full random lengths
- Tolerance of +/- 1/32"
- Predrilled available NIPDLXSS-same dimension as NIPDL page 63

PART NO.	NOMINAL SIZE	DIAMETER TOLERANCE CLASS "L"		LENGTH (in.)	HARDNESS DEPTH	WEIGHT (lbs./in.)
	(in.)	MIN.	MAX.	MAX.	MIN.	
NIL02SS-xx	1/8"	0.1248	0.1247	210	N/A	0.06
NIL03SS-xx	3/16"	0.1873	0.1872			0.10
NIL04SS-xx	1/4"	0.2498	0.2497			0.15
NIL06SS-xx	3/8"	0.3740	0.3745	252	0.040	0.031
NIL08SS-xx	1/2"	0.4990	0.4995	180	0.060	0.055
NIL10SS-xx	5/8"	0.6240	0.6245			0.086
NIL12SS-xx	3/4"	0.7490	0.7495			0.125
NIL16SS-xx	1"	0.9990	0.9995	204	0.080	0.222
NIL20SS-xx	1-1/4"	1.2490	1.2495			0.348
NIL24SS-xx	1-1/2"	1.4989	1.4994			0.500
NIL32SS-xx	2"	1.9987	1.9994		0.100	0.890

ALUMINUM PRE-DRILLED SUPPORT RAILS

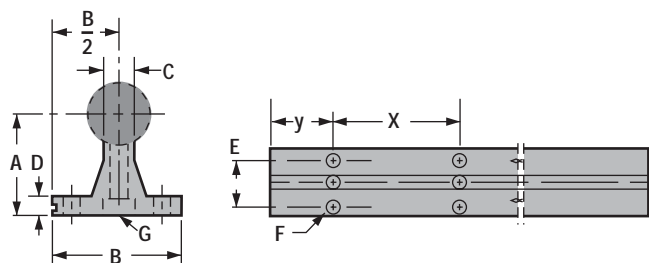

PART NO.	NOMINAL SIZE	A +/- .002	B	C	D	E	F		G		HOLE SPACING		WEIGHT (lbs./ft.)
	(in.)						BOLT	HOLE	SCREW	HOLE	X	y	
SR08PD-xx	1/2"	1.125	1.500	0.250	0.188	1.000	#6	0.169	6-32 x 7/8"	0.169	4.00	2.00	1.26
SR10PD-xx	5/8"	1.125	1.625	0.313	0.250	1.125	#8	0.193	8-32 x 7/8"	0.193			1.88
SR12PD-xx	3/4"	1.500	1.750	0.375		1.250	#10	0.221	10-32 x 7/8"	0.221	6.00	3.00	2.50
SR16PD-xx	1"	1.750	2.125	0.500		1.500	1/4"	0.281	1/4-20 x 1-1/2"	0.281			4.06
SR20PD-xx	1-1/4"	2.125	2.500	0.563	0.313	1.875	5/16"	0.343	5/16-18 x 1-3/4"	0.343	8.00	4.00	6.28
SR24PD-xx	1-1/2"	2.500	3.000	0.688	0.375	2.250	5/16"	0.343	3/8-16 x 2"	0.406			8.06
SR32PD-xx	2"	3.250	3.750	0.875	0.500	2.750	3/8"	0.406	1/2-13 x 2-1/2"	0.531	14.88		

NOTES: Specify length in part number. Example: for 1/2" shafting support rail to 24" length = SR08-PD-24 (Aluminum alloy construction)
 Shafts & support rails sold separately.
 Customer specifies "y" dimension.
 Maximum length, 4 ft.

ALUMINUM END SUPPORT BLOCKS

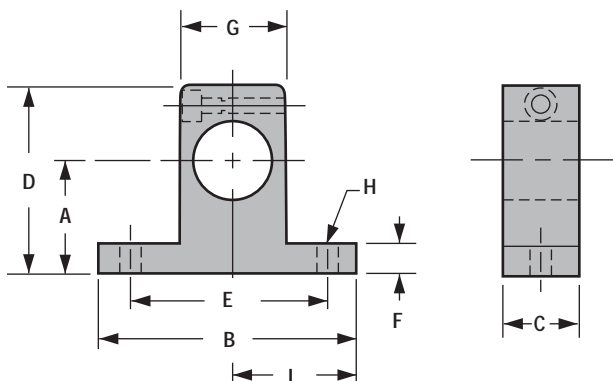

PART NO.	NOMINAL SIZE	A +/- .001	B	C	D	E +/- .001	F	G	H	I	WEIGHT (lbs.)	
	(in.)											BOLT
NSB04	1/4"	0.687	1.500	0.500	1.050	1.125		0.625	#6	5/32"	0.750	0.03
NSB06	3/8"	0.750	1.625	0.563	1.175	1.250	0.250	0.688	#8	3/16"	0.800	0.05
NSB08	1/2"	1.000	2.000	0.625	1.625	1.500		0.750			7/32"	1.000
NSB10	5/8"		2.500	0.688	1.750	1.875		0.313	1.000	#10	7/32"	1.250
NSB12	3/4"	1.250	2.500	0.750	2.055	2.000		1.000	1.375			0.21
NSB16	1"	1.500	3.055	1.000	2.500	2.500	0.375	1.375	1/4"	9/32"	1.625	0.40
NSB20	1-1/4"	1.750	3.750	1.125	3.000	3.000	0.438	1.750	5/16"	11/32"	2.000	0.80
NSB24	1-1/2"	2.000	4.375	1.250	3.435	3.500	0.500	2.000			2.375	1.10
NSB32	2"	2.500	5.500	1.500	4.375	4.375	0.625	2.625	3/8"	13/32"	3.000	1.90

Shaft rails and assemblies are available in long lengths, consult factory.

The data and specifications in this publication have been carefully compiled and are believed to be accurate and correct. However, it is the responsibility of the user to determine and ensure the suitability of Pacific Bearing® products for a specific application. Pacific Bearing's only obligation will be to repair or replace without charge, any defective components if returned promptly. No liability is assumed beyond such replacement. *Consult www.pacific-bearing.com for the latest technical updates.



ALUMINUM NON-DRILLED SUPPORT RAILS

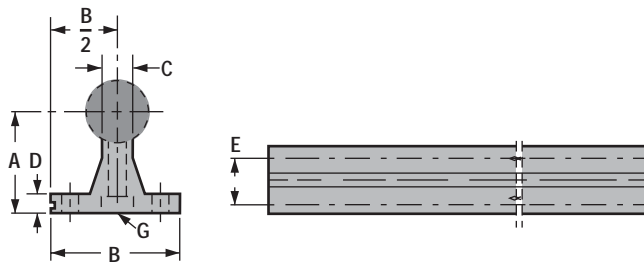

PART NO.	NOMINAL SIZE (in.)	A +/- .002	B	C	D	E	RECOMMENDED HOLE SIZE G		WEIGHT (lbs./ft.)
							SCREW	HOLE	
SR08-xx	1/2"	1.125	1.500	0.250	0.188	1.000	6-32 x 7/8"	0.169	1.26
SR10-xx	5/8"	1.125	1.625	0.313	0.250	1.125	8-32 x 7/8"	0.193	1.88
SR12-xx	3/4"	1.500	1.750	0.375	0.250	1.250	10-32 x 7/8"	0.221	2.50
SR16-xx	1"	1.750	2.125	0.500	0.250	1.500	1/4-20 x 1-1/2"	0.281	4.06
SR20-xx	1-1/4"	2.125	2.500	0.563	0.313	1.875	5/16-18 x 1-3/4"	0.343	6.28
SR24-xx	1-1/2"	2.500	3.000	0.688	0.375	2.250	3/8-16 x 2"	0.406	8.06
SR32-xx	2"	3.250	3.750	0.875	0.500	2.750	1/2-13 x 2-1/2"	0.531	14.88

NOTES: Specify length in part number. Example: for 1/2" shafting support rail to 24" length = SR08-24 (Aluminum alloy construction)
Shafts & support rails sold separately.
Maximum length = 4ft.

Inch Rails

STEEL SHAFT ALUMINUM RAIL ASSEMBLY



- 2 Piece Assemblies - Shaft & Support Rail
- RC60 Steel shaft and aluminum support rail
- Available cut-to-length
- Longer lengths available, optional shaft materials include (440 Stainless Steel & Feather Shafting)

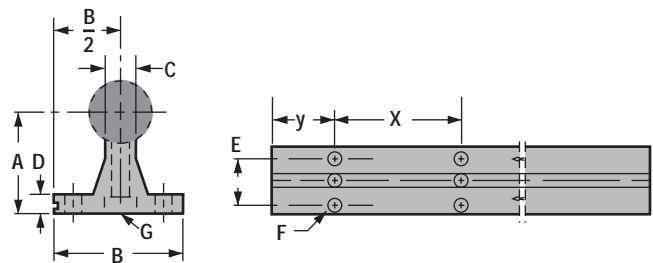

PART NO.	NOMINAL SHAFT SIZE (in.)	DIAMETER TOLERANCE		A +/- .002	B	C	D	E	F		HOLE SPACING		MAX. LENGTH *(ft.)	WEIGHT (lbs./in.)
		MIN.	MAX.						BOLT	HOLE	x	y		
SRA08-xx	1/2	0.4988	0.4996	1.125	1.500	0.250	0.188	1.000	#6	0.169	4	2	4	0.019
SRA10-xx	5/8	0.6238	0.6246		1.625	0.313		1.125	#8	0.193				0.030
SRA12-xx	3/4	0.7488	0.7496	1.500	1.750	0.375	0.250	1.250	#10	0.221	6	3	4	0.043
SRA16-xx	1	0.9988	0.9996	1.750	2.125	0.500		1.500	1/4"	0.281				0.076
SRA20-xx	1-1/4	1.2488	1.2496	2.125	2.500	0.563	0.313	1.875	5/16"	0.343	8	4	4	0.119
SRA24-xx	1-1/2	1.4987	1.4995	2.500	3.000	0.688	0.375	2.250	5/16"	0.343				0.172
SRA32-xx	2	1.9985	1.9995	3.250	3.750	0.875	0.500	2.750	3/8"	0.406	8	4	4	0.305

NOTE: Specify length in part number using inches. Example: for 1/2" shafting total length 36" long = SRA08-36.
Customer specifies "y" dimension.

Shaft rails and assemblies are available in long lengths, consult factory.

The data and specifications in this publication have been carefully compiled and are believed to be accurate and correct. However, it is the responsibility of the user to determine and ensure the suitability of Pacific Bearing[®] products for a specific application. Pacific Bearing's only obligation will be to repair or replace without charge, any defective components if returned promptly. No liability is assumed beyond such replacement. *Consult www.pacific-bearing.com for the latest technical updates.



CERAMIC COATED ALUMINUM SOLID SHAFTING



- Aluminum alloy base material
- RC70 ceramic coated finish
- Designed to run with Simplicity FrelonGOLD® lined bearings
- Non-magnetic and vibration resistant
- Weld splatter, paints, contaminants will not stick

PART NO.	NOMINAL SHAFT SIZE	DIAMETER TOLERANCE		MAX. LENGTH	WEIGHT
	(in.)	MIN.	MAX.	(in.)	(lbs./in.)
CC03-xx	3/16	0.1863	0.1871	144	0.003
CC04-xx	1/4	0.2488	0.2496		0.005
CC06-xx	3/8	0.3738	0.3746		0.010
CC08-xx	1/2	0.4988	0.4996		0.019
CC10-xx	5/8	0.6238	0.6246		0.030
CC12-xx	3/4	0.7488	0.7496		0.043
CC16-xx	1	0.9988	0.9996		0.077
CC20-xx	1-1/4	1.2488	1.2496		0.120
CC24-xx	1-1/2	1.4987	1.4995		0.173
CC32-xx	2	1.9985	1.9995		0.308

NOTES: Specify length in part number using inches.
 Example: for 1/2" shafting total length 36" long = CC08-36.
 Ends of cut-to-length shafting are not coated.
 Fully coated shafting is available on special request.

PRE-DRILLED & TAPPED CERAMIC COATED ALUMINUM SHAFTING

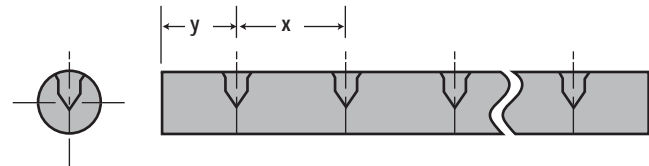

- Aluminum alloy base material
- RC70 ceramic coated finish
- Designed to run with Simplicity FrelonGOLD® lined bearings
- Interchanges with standard pre-drilled shafting
- Non-magnetic and vibration resistant
- Weld splatter, paints, contaminants will not stick

PART NO.	NOMINAL SHAFT SIZE	DIAMETER TOLERANCE		HOLE SPACING		THREAD	MAX. LENGTH	WEIGHT
	(in.)	MIN.	MAX.	x	y		(in.)	(lbs./in.)
CCPDL08-xx	1/2	0.4988	0.4996	4	2	6-32	144	0.019
CCPDL10-xx	5/8	0.6238	0.6246			8-32		0.030
CCPDL12-xx	3/4	0.7488	0.7496	6	3	10-32		0.043
CCPDL16-xx	1	0.9988	0.9996			1/4-20		0.077
CCPDL20-xx	1-1/4	1.2488	1.2496			5/16-18		0.120
CCPDL24-xx	1-1/2	1.4987	1.4995	8	4	3/8-16		0.173
CCPDL32-xx	2	1.9985	1.9995			1/2-13		0.308

NOTES: Specify length in part number using inches.
 Example: for 1/2" shafting total length 36" long = CCPDL08-36.
 Ends of cut-to-length shafting are not coated.
 Fully coated shafting is available on special request.
 Counterbore .063" from top.
 Customer specifies "y" dimension.

The data and specifications in this publication have been carefully compiled and are believed to be accurate and correct. However, it is the responsibility of the user to determine and ensure the suitability of Pacific Bearing® products for a specific application. Pacific Bearing's only obligation will be to repair or replace without charge, any defective components if returned promptly. No liability is assumed beyond such replacement. *Consult www.pacific-bearing.com for the latest technical updates.

CERAMIC COATED ALUMINUM RAIL ASSEMBLY

- Aluminum alloy base material
- RC70 ceramic coated finish
- One piece integrated design eliminates assembly time
- Weld splatter, paints, and other contaminants will not stick to the shaft
- Non-magnetic and vibration resistant
- Economical, weight saving alternative to traditional steel shafting
- Designed to run with Simplicity FrelonGOLD® lined linear bearings
- Available drilled and undrilled



Inch Feather Rails®

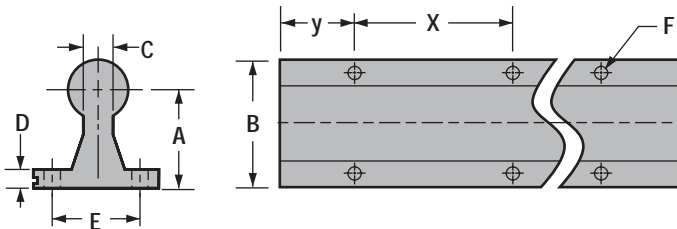

PART NO.	NOMINAL SHAFT SIZE (in.)	DIAMETER TOLERANCE		A	B	C	D	E	F		HOLE SPACING		MAX. LENGTH *(ft.)	WEIGHT (lbs./in.)
		MIN.	MAX.						BOLT	HOLE	X	y		
CCR08-xx	1/2	0.4988	0.4996	1.125	1.500	0.250	0.188	1.000	#6	0.169	4	2	4	0.019
CCR10-xx	5/8	0.6238	0.6246		1.625	0.313		1.125	#8	0.193				0.030
CCR12-xx	3/4	0.7488	0.7496	1.500	1.750	0.375	0.250	1.250	#10	0.221	6	3		0.043
CCR16-xx	1	0.9988	0.9996	1.750	2.125	0.500		1.500	1/4"	0.281				0.076
CCR20-xx	1-1/4	1.2488	1.2496	2.125	2.500	0.563	0.313	1.875	5/16"	0.343	8	4		0.119
CCR24-xx	1-1/2	1.4987	1.4995	2.500	3.000	0.688	0.375	2.250						0.172
CCR32-xx	2	1.9985	1.9995	3.250	3.750	0.875	0.500	2.750	3/8"	0.406	8	4	0.305	

NOTES: Specify length in part number using inches. Example: for 1/2" shafting total length 36" long = CCR08-36.
 Cut-to-length rails may not be coated on the ends.
 Customer specifies "y" dimension.
 DO NOT use with Linear Ball Bearings.

Shaft rails and assemblies are available in long lengths, consult factory.

The data and specifications in this publication have been carefully compiled and are believed to be accurate and correct. However, it is the responsibility of the user to determine and ensure the suitability of Pacific Bearing® products for a specific application. Pacific Bearing's only obligation will be to repair or replace without charge, any defective components if returned promptly. No liability is assumed beyond such replacement. *Consult www.pacific-bearing.com for the latest technical updates.



COMPLETE PRODUCT OFFERING

- RC60 Steel
- 440 Stainless Steel
- Custom Options
- Cut-to-Length
- Random Lengths
- Pre-drilled and Tapped Shafting
- Joinable for even longer lengths

RC60 STEEL SHAFTING

- RC60 case hardened steel
- Polished for optimum surface finish



- Suitable for Simplicity® bearings and linear ball bearings
- Available cut-to-length or in full random lengths

PRE-DRILLED & TAPPED RC60 STEEL SHAFTING*

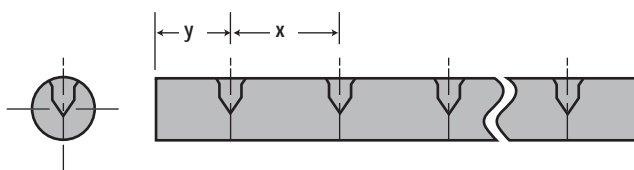

SMALL DIAMETER RC60 STEEL SHAFTING*

PART NO.	NOMINAL SIZE	DIAMETER TOLERANCE CLASS "M"		LENGTH in m*	HARDNESS DEPTH	WEIGHT (kg/m)
	(mm)	MIN.	MAX.	MAX.	MIN. (mm)	
NIM03-xx	3	2.991	3	6.4	1.0	0.06
NIM04-xx	4	3.991	4	6.4	1.0	0.1
NIM05-xx	5	4.991	5	6.4	1.0	0.15
NIM06-xx	6	5.991	6	6.4	1.0	0.23
NIM08-xx	8	7.991	8	6.4	1.0	0.39
NIM10-xx	10	9.991	10	6.4	1.0	0.62

PART NO.	NOMINAL SIZE	DIAMETER TOLERANCE CLASS "M"	HOLE SPACING		THREAD	MAX. LENGTH	WEIGHT (kg/m)
	(mm)	(µm)	x	y		(m)	
NIPDM08-xx	8	+0/-9	101.6	50.8	M2 x .4	5.0	0.39
NIPDM10-xx	10	+0/-9	101.6	50.8	M3 x .5	5.0	0.62
NIPDM12-xx	12	+0/-11	150	75	M4 x .7	5.7	0.89
NIPDM16-xx	16	+0/-11	150	75	M5 x .8	5.7	1.57
NIPDM20-xx	20	+0/-13	150	75	M6 x 1.0	5.7	2.45
NIPDM25-xx	25	+0/-13	200	100	M8 x 1.25	5.7	3.80
NIPDM30-xx	30	+0/-13	200	100	M10 x 1.5	5.7	5.50

NOTES: Specify length in part number using mm.
 For random lengths, add "R" to the part number.
 Example: for 12mm shafting total length 97mm = NIPDM12-97
 Customer specifies "y" dimension.

RC60 STEEL SHAFTING*

PART NO.	NOMINAL SIZE	DIAMETER TOLERANCE CLASS "M"		LENGTH in m*	HARDNESS DEPTH	WEIGHT (kg/m)
	(mm)	MIN.	MAX.	MAX.	MIN. (mm)	
NIM03-xx	3	2.991	3	6.4	1.0	0.06
NIM04-xx	4	3.991	4	6.4	1.0	0.1
NIM05-xx	5	4.991	5	6.4	1.0	0.15
NIM06-xx	6	5.991	6	6.4	1.0	0.23
NIM08-xx	8	7.991	8	6.4	1.0	0.39
NIM10-xx	10	9.991	10	6.4	1.0	0.62
NIM12-xx	12	11.989	12	4.6	1.0	0.89
NIM16-xx	16	15.989	16	4.6	1.7	1.57
NIM20-xx	20	19.987	20	4.6	1.7	2.45
NIM25-xx	25	24.987	25	5.2	2.7	3.8
NIM30-xx	30	29.987	30	5.2	2.7	5.5
NIM40-xx	40	39.984	40	5.2	2.7	9.8
NIM50-xx	50	49.984	50	5.2	3.7	15.3
NIM60-xx	60	59.981	60	5.2	3.7	22.2
NIM80-xx	80	79.981	80	5.2	3.7	39.5

*NOTES: Specify length in part number using millimeters.
 Example: for 25 mm shafting total length 900mm = NIM25-900

RC60 Metric Shafting.....	68
440 Stainless Steel Shafting	69
Ceramic Coated Aluminum Solid Shafting	69
Pre-drilled & Tapped Ceramic Coated Aluminum Shafting	69
Metric Bearings.....	18-19
Metric Ball Bearings.....	88
Metric Ball Bearing Pillow Blocks	104
Metric Pillow Blocks	20-21
Compact ISO Metric Thin Wall Bearings.....	22-23
Metric Flange Mounted Bearings	25-27
Inch Shafting	63

Shaft rails and assemblies are available in long lengths, consult factory.

The data and specifications in this publication have been carefully compiled and are believed to be accurate and correct. However, it is the responsibility of the user to determine and ensure the suitability of Pacific Bearing® products for a specific application. Pacific Bearing's only obligation will be to repair or replace without charge, any defective components if returned promptly. No liability is assumed beyond such replacement. *Consult www.pacific-bearing.com for the latest technical updates.



440 STAINLESS STEEL SHAFTING



- 440 Stainless Steel
- Suitable for linear ball bearings
- Available cut-to-length or in full random lengths
- Tolerance of +/- .79375

PART NO.	NOMINAL SIZE	DIAMETER TOLERANCE CLASS "M"	MAX. LENGTH	HARDNESS DEPTH	WEIGHT
	(mm)	(µm)	(m)	MAX.	(kg/m)
NIM03SS-xx	3	+0/-8	5.0	1.0	0.06
NIM04SS-xx	4	+0/-8	5.0	1.0	0.10
NIM05SS-xx	5	+0/-8	5.0	1.0	0.15
NIM06SS-xx	6	+0/-8	5.0	1.0	0.23
NIM08SS-xx	8	+0/-9	5.0	1.0	0.39
NIM10SS-xx	10	+0/-9	5.0	1.0	0.62
NIM12SS-xx	12	+0/-11	5.7	1.0	0.89
NIM16SS-xx	16	+0/-11	5.7	1.7	1.57
NIM20SS-xx	20	+0/-13	5.7	1.7	2.45
NIM25SS-xx	25	+0/-13	5.7	2.7	3.80
NIM30SS-xx	30	+0/-13	5.7	2.7	5.50

CERAMIC COATED ALUMINUM SOLID SHAFTING



- Aluminum alloy base material
- RC70 ceramic coated finish
- Designed to run with Simplicity FrelonGOLD® lined bearings
- Non-magnetic and vibration resistant
- Weld splatter, paints, contaminants will not stick

PART NO.	NOMINAL SIZE	DIAMETER TOLERANCE CLASS "M"	MAX. LENGTH	WEIGHT
	(mm)	(µm)	(m)	(kg/m)
CCM03-xx	3	+0/-8	3.7	0.01
CCM04-xx	4	+0/-8	3.7	0.02
CCM05-xx	5	+0/-8	3.7	0.03
CCM06-xx	6	+0/-8	3.7	0.04
CCM08-xx	8	+0/-9	3.7	0.07
CCM10-xx	10	+0/-9	3.7	0.10
CCM12-xx	12	+0/-11	3.7	0.15
CCM16-xx	16	+0/-11	3.7	0.26
CCM20-xx	20	+0/-13	3.7	0.41
CCM25-xx	25	+0/-13	3.7	0.63
CCM30-xx	30	+0/-13	3.7	0.92
CCM40-xx	40	+0/-16	3.7	1.63
CCM50-xx	50	+0/-16	3.7	2.55
CCM60-xx	60	+0/-19	3.7	3.70
CCM80-xx	80	+0/-19	3.7	6.58

NOTES: Specify length in part number using mm.
 Example: for 8mm shafting total length 97mm = CCM08-97
 Ends of cut-to-length shafting are not coated.
 Fully coated shafting is available on special request.

PRE-DRILLED & TAPPED CERAMIC COATED ALUMINUM SHAFTING



- Aluminum alloy base material
- RC70 ceramic coated finish
- Designed to run with Simplicity FrelonGOLD® lined bearings
- Interchanges with standard pre-drilled shafting
- Non-magnetic and vibration resistant
- Weld splatter, paints, contaminants will not stick

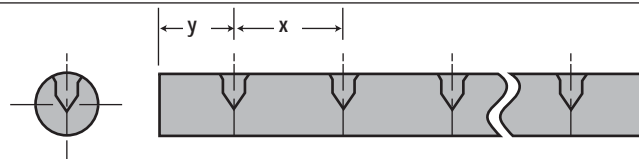

PART NO.	NOMINAL SIZE	DIAMETER TOLERANCE CLASS "M"	HOLE SPACING		THREAD	MAX. LENGTH	WEIGHT
	(mm)	(µm)	x	y		(m)	(kg/m)
CCMDL08-xx	8	+0/-9	101.6	50.8	M2 x .4	3.7	0.07
CCMDL10-xx	10	+0/-9	101.6	50.8	M3 x .5	3.7	0.10
CCMDL12-xx	12	+0/-11	150	75	M4 x .7	3.7	0.15
CCMDL16-xx	16	+0/-11	150	75	M5 x .8	3.7	0.26
CCMDL20-xx	20	+0/-13	150	75	M6 x 1.0	3.7	0.41
CCMDL25-xx	25	+0/-13	200	100	M8 x 1.25	3.7	0.63
CCMDL30-xx	30	+0/-13	200	100	M10 x 1.5	3.7	0.92

NOTES: Specify length in part number using mm.
 Example: for 10mm shafting total length 97mm = CCMDL08-97.
 Ends of cut-to-length shafting are not coated.
 Fully coated shafting is available on special request.
 Customer specifies "y" dimension.

Shaft rails and assemblies are available in long lengths, consult factory.

The data and specifications in this publication have been carefully compiled and are believed to be accurate and correct. However, it is the responsibility of the user to determine and ensure the suitability of Pacific Bearing® products for a specific application. Pacific Bearing's only obligation will be to repair or replace without charge, any defective components if returned promptly. No liability is assumed beyond such replacement. *Consult www.pacific-bearing.com for the latest technical updates.



Simplicity® Ball Bearings

Linear Ball Bearings - Inch Series

Linear Motion Systems

Ball Bearings

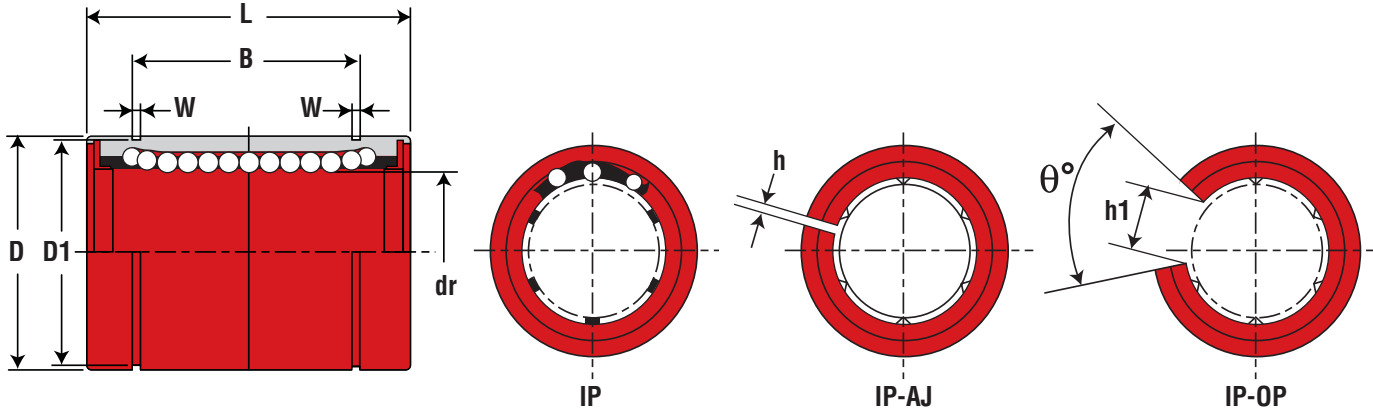

IP SERIES - DIMENSIONAL INFORMATION

NOMINAL SHAFT DIAMETER (Inch /mm)	PART NUMBER					MAJOR DIMENSIONS & TOLERANCES					
	STANDARD CLOSE POLYMER CAGE	BALL CIRCUIT	WEIGHT (g)	STANDARD OPEN POLYMER CAGE	ADJUSTABLE POLYMER CAGE	dr (Inch/mm)	TOLERANCE (Inch/μm)	D (Inch/mm)	TOLERANCE (Inch/μm)	L (Inch/mm)	TOLERANCE (Inch/mm)
1/4 6.350	IP4G	4	8	-	-	0.2500 6.350	0/- .0004 0/-9	0.5000 12.700	0/- .00045 0/-11	0.7500 19.050	0/- .008 0/-0.2
3/8 9.525	IP6G		14	-	-	0.3750 9.525		0.6250 15.875	0/- .00050 0/-13	0.8750 22.225	
1/2 9.525	IP8G		37	IP8G-OP	IP8G-AJ	0.5000 12.700		0.8750 22.225		1.2500 31.750	
5/8 15.875	IP10G	5	76	IP10G-OP	IP10G-AJ	0.6250 15.875		1.1250 28.575	1.5000 38.100		
3/4 19.050	IP12G		95	IP12G-OP	IP12G-AJ	0.7500 19.050	1.2500 31.750	0/- .00065 0/-16	1.625 41.275		
1 25.400	IP16G	6	200	IP16G-OP	IP16G-AJ	1.0000 25.400	0/- .0004 0/-10	1.5625 39.688	2.2500 57.150	0/- .012 0/-0.3	
1-1/4 31.750	IP20G		440	IP20G-OP	IP20G-AJ	1.2500 31.750		2.0000 50.800	0/- .00075 0/-19		2.6250 66.675
1-1/2 38.100	IP24G		670	IP24G-OP	IP24G-AJ	1.5000 38.100	2.3750 60.325	0/- .0005 0/-12	3.0000 76.200		
2 50.800	IP32G		1,140	IP32G-OP	IP32G-AJ	2.0000 50.800	3.0000 76.200	0/- .00090 0/-22	4.0000 101.600		

The data and specifications in this publication have been carefully compiled and are believed to be accurate and correct. However, it is the responsibility of the user to determine and ensure the suitability of Pacific Bearing® products for a specific application. Pacific Bearing's only obligation will be to repair or replace without charge, any defective components if returned promptly. No liability is assumed beyond such replacement. *Consult www.pacific-bearing.com for the latest technical updates.

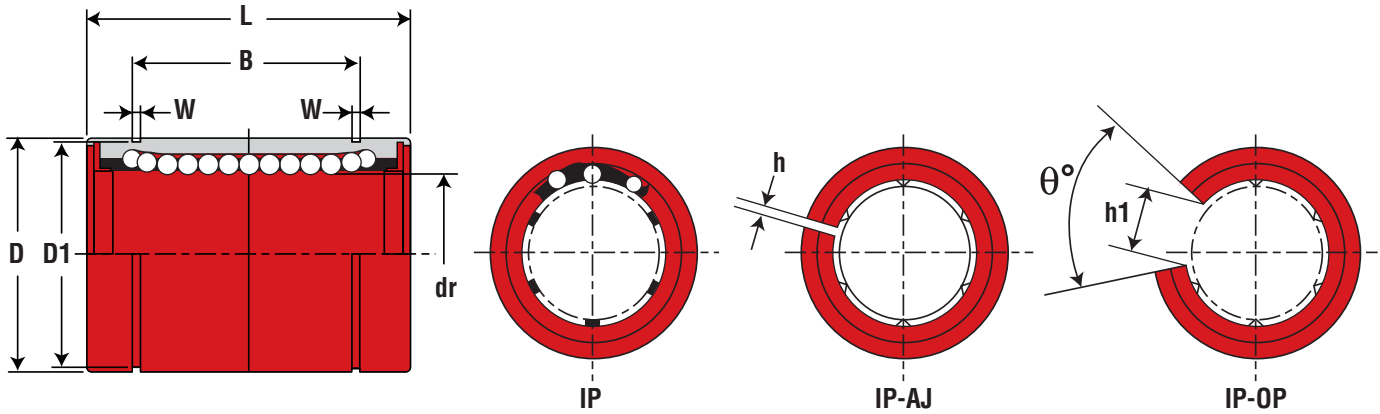

IP SERIES - DIMENSIONAL INFORMATION (cont.)

(Standard Steel Finish)

MAJOR DIMENSIONS & TOLERANCES								LOAD RATING				NOMINAL SHAFT DIAMETER (inch/mm)
B MAX/MIN (inch/mm)	W MIN (inch/mm)	D1 (inch/mm)	h (inch/mm)	h1 (inch/mm)	θ°	ECCENTRICITY (inch/ μ m)	MAX RADIAL CLEARANCE (inch/ μ m)	DYNAMIC C (N)	DYNAMIC C (lbs.)	STATIC Co (N)	STATIC Co (lbs.)	
.515/.499 13.091/12.675	.0390 0.992	0.4687 11.906	.04 1	-	-	.0005 12	-.0001 -3	206	46	265	60	1/4 6.350
.640/.624 16.256/15.850	.0390 0.992	0.5880 14.935		-	-			225	51	314	71	3/8 9.525
.967/.951 24.562/24.155	.0459 1.168	0.8209 20.853	.06 1.5	0.3400 7.937	80		-.0001 -4	510	115	784	176	1/2 9.525
1.108/1.092 28.143/27.737	.0559 1.422	1.0590 26.899		0.3750 9.525	80	774		174	1,180	265	5/8 15.875	
1.170/1.154 29.718/29.312	.0559 1.422	1.1760 29.870	.10 2.5	0.4375 11.112	60	.0006 15	-.0002 -6	862	194	1,370	308	3/4 19.050
1.759/1.741 44.679/44.421	.0679 1.727	1.4687 37.306		0.5625 14.287	60			980	220	1,570	353	1 25.400
2.009/1.991 51.029/50.571	.0679 1.727	1.8859 47.904	.12 3	0.6250 15.875	50	.0008 20	-.0003 -8	1,570	353	2,740	616	1-1/4 31.750
2.415/2.397 61.341/60.884	.0859 2.184	2.2389 56.870		0.7500 19.050				50	2,180	490	4,020	904
3.195/3.177 81.153/80.696	.1029 2.616	2.8379 72.085		1.000 25.400		.0010 25	-.0005 -13	3,820	859	7,940	1,785	2 50.800

The data and specifications in this publication have been carefully compiled and are believed to be accurate and correct. However, it is the responsibility of the user to determine and ensure the suitability of Pacific Bearing® products for a specific application. Pacific Bearing's only obligation will be to repair or replace without charge, any defective components if returned promptly. No liability is assumed beyond such replacement. *Consult www.pacific-bearing.com for the latest technical updates.



Simplicity® Ball Bearings

Double Wide Linear Ball Bearings - Inch Series

Linear Motion Systems

Ball Bearings

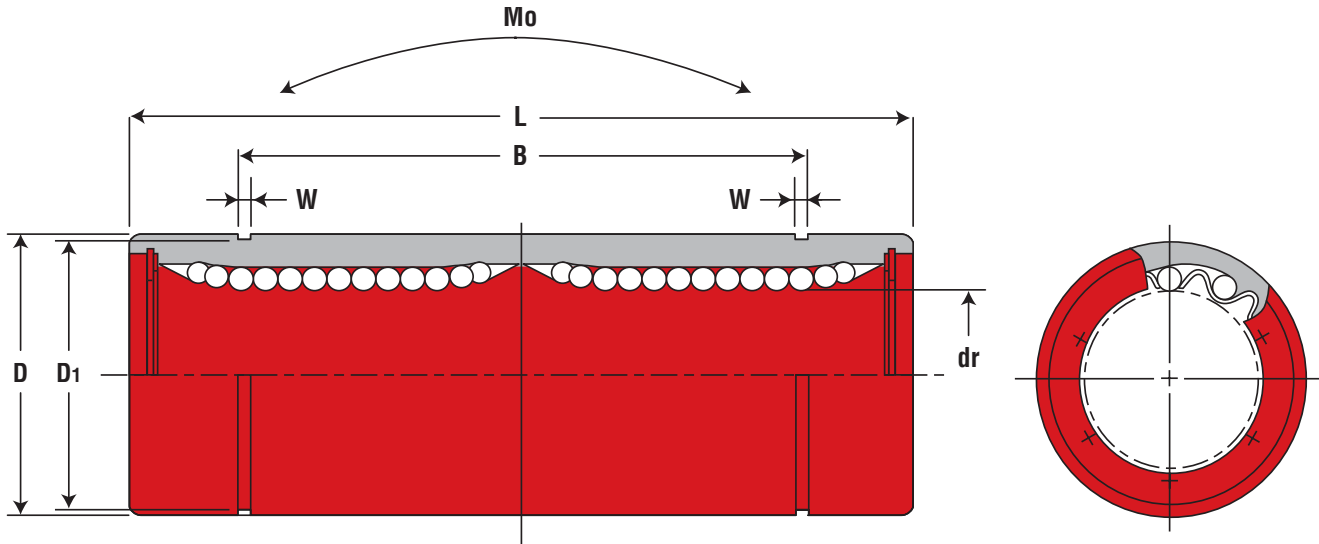

IP-W SERIES - DIMENSIONAL INFORMATION

NOMINAL SHAFT DIAMETER (Inch/mm)	PART NUMBER	MAJOR DIMENSIONS & TOLERANCES								
		BALL CIRCUIT	WEIGHT (g)	dr (inch/mm)	TOLERANCE (inch/mm)	D (inch/mm)	TOLERANCE (inch/ μ m)	L (inch/mm)	TOLERANCE (inch/mm)	
1/4 6.350	IP4GW	4	18	0.2500 6.350	0/-0.0004 0/-10	0.5000 12.700	0/-0.0005 0/-13	1.3750 34.925	0/-0.012 0/-0.3	
3/8 9.525	IP6GW		28	0.3750 9.525		0.6250 15.875		1.5938 40.481		
1/2 12.700	IP8GW		80	0.5000 12.700		0.8750 22.225		2.3750 60.235		
5/8 15.875	IP10GW	5	160	0.6250 15.875		1.1250 28.575	2.8125 71.438			
3/4 19.050	IP12GW		195	0.7500 19.050	1.2500 31.750	3.0937 78.581				
1 25.400	IP16GW	6	410	1.0000 25.400	0/-0.0005 0/-12	1.5625 39.688	0/-0.00075 0/-19	4.2813 108.744		0/-0.016 0/-0.4
1-1/4 31.750	IP20GW		820	1.2500 31.750		2.0000 50.800		5.0000 127.000		
1-1/2 38.100	IP24GW		1,250	1.5000 38.100	0/-0.0006 0/-15	2.3750 60.325	0/-0.0009 0/-22	5.6875 144.463		
2 50.800	IP32GW		2,350	2.0000 50.800		3.0000 76.200		7.7500 196.850		

The data and specifications in this publication have been carefully compiled and are believed to be accurate and correct. However, it is the responsibility of the user to determine and ensure the suitability of Pacific Bearing® products for a specific application. Pacific Bearing's only obligation will be to repair or replace without charge, any defective components if returned promptly. No liability is assumed beyond such replacement. *Consult www.pacific-bearing.com for the latest technical updates.



Simplicity® Ball Bearings

Double Wide Linear Ball Bearings - Inch Series

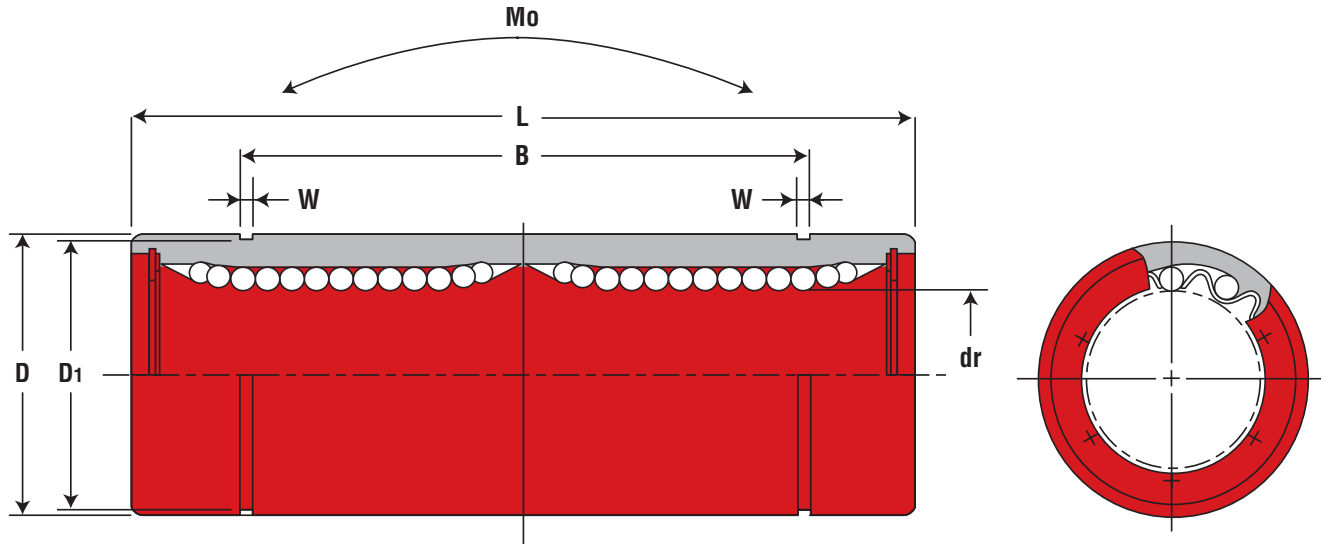

IP-W SERIES - DIMENSIONAL INFORMATION (cont.)

(Standard Steel Finish)

MAJOR DIMENSIONS & TOLERANCES					LOAD RATING				ALLOWABLE STATIC MOMENT Mo (N-m)	NOMINAL SHAFT DIAMETER (inch/mm)
B (inch/mm)	TOLERANCE (inch/mm)	W MIN (inch/mm)	D1 (inch/mm)	ECCENTRICITY (inch/μm)	DYNAMIC C (N)	DYNAMIC C (lbs.)	STATIC Co (N)	STATIC Co (lbs.)		
1.0220 25.959	0/-0.012 0/-0.3	.0390 0.992	0.4687 11.906	.0006 15	323	73	530	119	2	1/4 6.350
1.2716 32.298		.0390 0.992	0.5880 14.935		353	79	630	142	2.7	3/8 9.525
1.9250 48.895		.0459 1.168	0.8209 20.853		813	183	1,570	353	11.5	1/2 12.700
2.2079 56.080		.0559 1.422	1.0590 26.899		1,230	277	2,350	528	20	5/8 15.875
2.3314 59.218		1.1760 29.870	.0679 1.727		.0008 20	1,370	308	2,740	616	26.5
3.5094 89.139	1.4687 37.306	1,570		353		3,140	706	41.2	1 25.400	
4.0094 101.839	1.8859 47.904	.0010 25		2,500		562	5,490	1,234	84.8	1-1/4 31.750
4.8236 122.519	2.2389 56.870		3,430	771	8,040	1,807	143	1-1/2 38.100		
6.3834 162.138	0/-0.16 0/-0.4	.1029 2.616	2.8379 72.085	.0012 30	6,080	1,367	15,900	3,574	399	2 50.800

The data and specifications in this publication have been carefully compiled and are believed to be accurate and correct. However, it is the responsibility of the user to determine and ensure the suitability of Pacific Bearing® products for a specific application. Pacific Bearing's only obligation will be to repair or replace without charge, any defective components if returned promptly. No liability is assumed beyond such replacement. *Consult www.pacific-bearing.com for the latest technical updates.



Simplicity® Ball Bearings

Round Flange Mount - Inch Series

Linear Motion Systems

Flange Mount

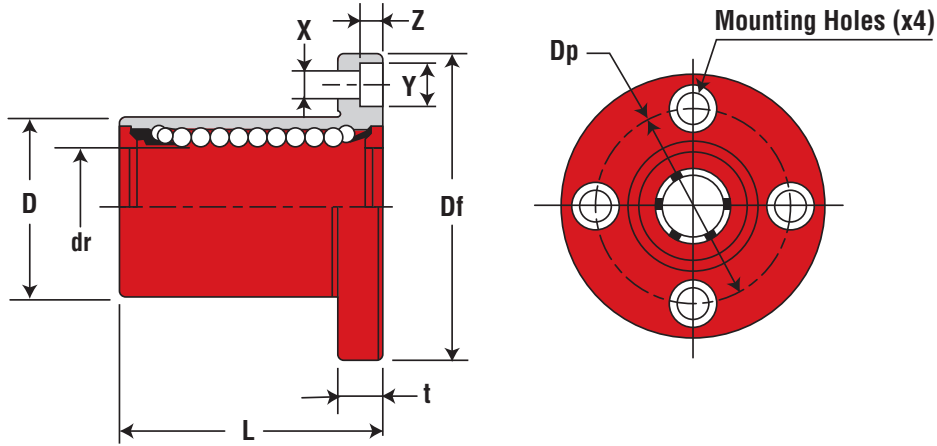

IPF SERIES - DIMENSIONAL INFORMATION

NOMINAL SHAFT DIAMETER (inch/mm)	PART NUMBER	MAJOR DIMENSIONS & TOLERANCES							
		POLYMER CAGE	BALL CIRCUIT	WEIGHT (g)	dr (inch/mm)	TOLERANCE (inch/μm)	D (inch/mm)	TOLERANCE (inch/μm)	L (inch/mm)
1/4 6.350	IPF4G	4	32	0.2500 6.350	0/-0.0004 0/-9	0.5000 12.700	0/-0.0005 0/-13	0.7500 19.050	±0.012 ±0.3
3/8 9.525	IPF6G					0.6250 15.875		0.8750 22.225	
1/2 6.350	IPF8G					0.8750 22.225		1.2500 31.750	
5/8 15.875	IPF10G	5	140	0.6250 15.875	0/-0.0004 0/-10	1.1250 28.575	0/-0.00065 0/-16	1.5000 38.100	
3/4 19.050	IPF12G					1.2500 31.750		1.6250 41.275	
1 25.400	IPF16G	6	325	1.0000 25.400	0/-0.0005 0/-12	1.5625 39.688	0/-0.00075 0/-19	2.5000 63.500	
1-1/4 31.750	IPF20G					2.0000 50.800		2.6250 66.675	
1-1/2 38.100	IPF24G					2.3750 60.325		3.0000 76.200	
2 50.800	IPF32G					3.0000 76.200		4.0000 101.600	

The data and specifications in this publication have been carefully compiled and are believed to be accurate and correct. However, it is the responsibility of the user to determine and ensure the suitability of Pacific Bearing® products for a specific application. Pacific Bearing's only obligation will be to repair or replace without charge, any defective components if returned promptly. No liability is assumed beyond such replacement. *Consult www.pacific-bearing.com for the latest technical updates.



Simplicity® Ball Bearings

Round Flange Mount - Inch Series

Linear Motion Systems

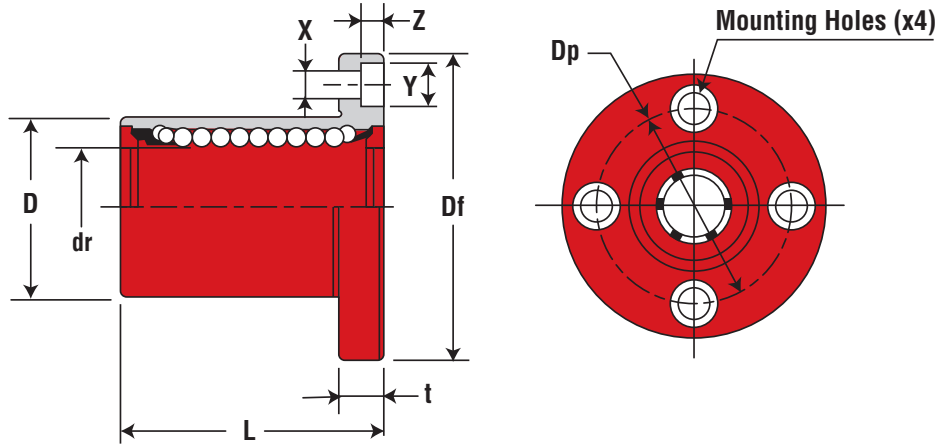

Flange Mount

IPF SERIES - DIMENSIONAL INFORMATION (cont.)

(Standard Steel Finish)

MAJOR DIMENSIONS & TOLERANCES						LOAD RATING				NOMINAL SHAFT DIAMETER (inch/mm)
Df (inch/mm)	t (inch/mm)	Dp (inch/mm)	X x Y x Z (inch/mm)	ECCENTRICITY ID to OD (inch/μm)	PERPENDICULARITY FLANGE FACE to ID (inch/μm)	DYNAMIC C (N)	DYNAMIC C (lbs.)	STATIC Co (N)	STATIC Co (lbs.)	
1.2500 31.750	.2190 5.556	0.8750 22.225	.156 x .250 x .141 3.969 x 6.350 x 3.572	.0005 12	.0005 12	206	46	265	60	1/4 6.350
1.5000 38.100	.2500 6.350	1.0620 26.988	.1875 x .297 x .172 4.763 x 7.541 x 4.366			225	51	314	71	3/8 9.525
1.7500 44.450	.2500 6.350	1.3120 33.338	.1875 x .297 x .172 4.763 x 7.541 x 4.366			510	115	784	176	1/2 6.350
2.0000 50.800	.2500 6.350	1.5620 39.688	.1875 x .297 x .172 4.763 x 7.541 x 4.366			774	174	1,180	265	5/8 15.875
2.1875 55.563	.3125 7.938	1.7180 43.660	.219 x .344 x .203 5.556 x 8.731 x 5.159	.0006 15	.0006 15	862	194	1,370	308	3/4 19.050
2.5000 63.500	.3125 7.938	2.0310 51.594	.219 x .344 x .203 5.556 x 8.731 x 5.159			980	220	1,570	353	1 25.400
3.1250 79.375	.3750 9.525	2.5625 65.088	.281 x .406 x .266 7.144 x 10.312 x 6.747	.0008 20	.0008 20	1,570	353	2,740	616	1-1/4 31.750
3.7500 95.250	.5000 12.700	3.0625 77.788	.344 x .500 x .328 8.731 x 12.700 x 8.334	.0010 25	.0010 25	2,180	490	4,020	904	1-1/2 38.100
4.3750 111.125	.5000 12.700	3.6875 93.662	.344 x .500 x .328 8.731 x 12.700 x 8.334			3,820	859	7,940	1,785	2 50.800

The data and specifications in this publication have been carefully compiled and are believed to be accurate and correct. However, it is the responsibility of the user to determine and ensure the suitability of Pacific Bearing® products for a specific application. Pacific Bearing's only obligation will be to repair or replace without charge, any defective components if returned promptly. No liability is assumed beyond such replacement. *Consult www.pacific-bearing.com for the latest technical updates.



Simplicity® Ball Bearings

Round Flange Mount Double Wide - Inch Series

Linear Motion Systems

Flange Mount

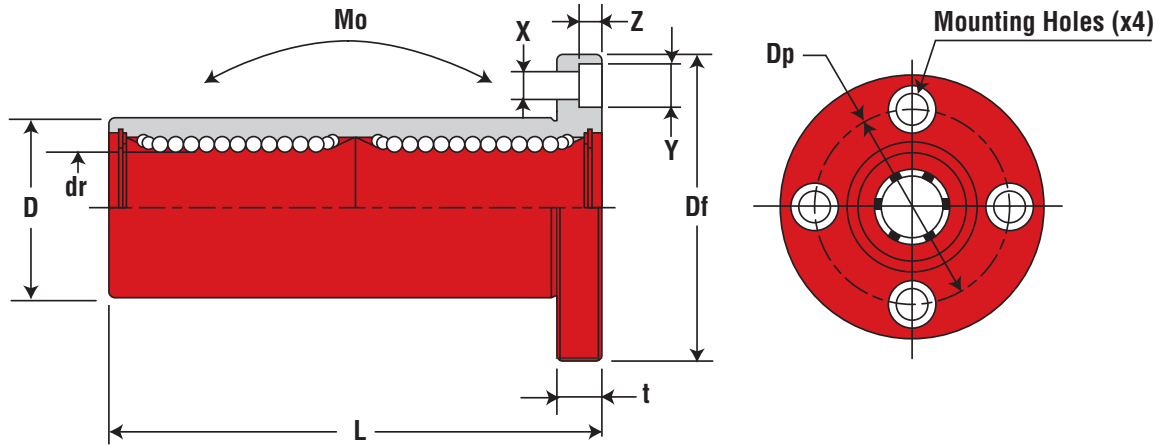

IPF-W SERIES - DIMENSIONAL INFORMATION

PART NUMBER		MAJOR DIMENSIONS & TOLERANCES								
NOMINAL SHAFT DIAMETER (inch/mm)	POLYMER CAGE	BALL CIRCUIT	WEIGHT (g)	dr (inch/mm)	TOLERANCE (inch/ μ m)	D (inch/mm)	TOLERANCE (inch/ μ m)	L (inch/mm)	TOLERANCE (inch/mm)	Df (inch/mm)
1/4 6.350	IPF4GW	4	40	0.2500 6.350	0/-0.0004 0/-10	0.5000 12.700	0/-0.0005 0/-13	1.375 34.925	± 0.012 ± 0.3	1.2500 31.750
3/8 9.525	IPF6GW		60	0.3750 9.525		0.6250 15.875		1.5938 40.481		1.5000 38.100
1/2 12.700	IPF8GW		126	0.5000 12.700		0.8750 22.225	0/-0.00065 0/-16	2.3750 60.325		1.7500 44.450
5/8 15.875	IPF10GW	5	215	0.6250 15.875	1.1250 28.575		2.8125 71.438	2.0000 50.800		
3/4 19.050	IPF12GW		280	0.7500 19.050	1.2500 31.750	0/-0.00075 0/-19	3.0937 78.581	2.1875 55.563		
1 25.400	IPF16GW	6	515	1.0000 25.400	0/-0.0006 0/-15	1.5625 39.688		4.2813 108.744		2.5000 63.500
1-1/4 31.750	IPF20GW		1,020	1.2500 31.750		2.0000 50.800	0/-0.0009 0/-22	5.000 127.000		3.1250 79.375
1-1/2 38.100	IPF24GW		1,630	1.5000 38.100		2.3750 60.325		5.6875 144.463		3.7500 95.250
2 50.800	IPF32GW		2,800	2.0000 50.800		3.0000 76.200	0/-0.0010 0/-25	7.7500 196.850		4.3750 111.125

The data and specifications in this publication have been carefully compiled and are believed to be accurate and correct. However, it is the responsibility of the user to determine and ensure the suitability of Pacific Bearing® products for a specific application. Pacific Bearing's only obligation will be to repair or replace without charge, any defective components if returned promptly. No liability is assumed beyond such replacement. *Consult www.pacific-bearing.com for the latest technical updates.



Simplicity® Ball Bearings

Round Flange Mount Double Wide - Inch Series

Linear Motion Systems

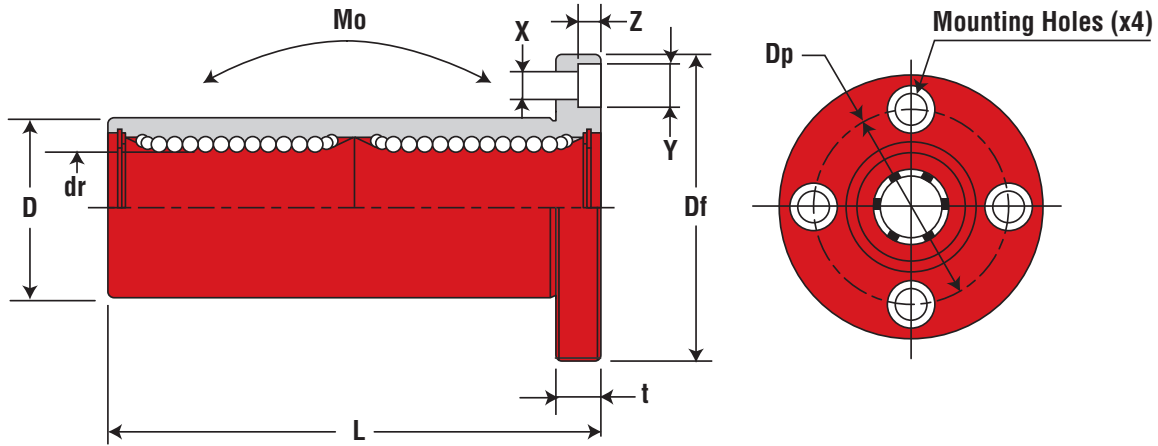

Flange Mount

IPF-W SERIES - DIMENSIONAL INFORMATION (cont.)

(Standard Steel Finish)

MAJOR DIMENSIONS & TOLERANCES					LOAD RATING					
t (inch/ mm)	Dp (inch/ mm)	X x Y x Z (inch/ mm)	ECCENTRICITY ID to OD (inch/ µm)	PERPENDICULARITY FLANGE FACE to ID (inch/ µm)	DYNAMIC C (N)	DYNAMIC C (lbs.)	STATIC Co (N)	STATIC Co (lbs.)	ALLOWABLE STATIC MOMENT Mo (N-m)	NOMINAL SHAFT DIAMETER (inch/ mm)
0.219 5.556	0.8750 22.225	.156 x .250 x .141 3.969 x 6.350 x 3.572	.0006 15	.0006 15	323	73	530	119	2	1/4 6.350
.2500 6.350	1.0620 26.988	.1875 x .297 x .172 4.763 x 7.541 x 4.366			353	79	630	142	2.7	3/8 9.525
.2500 6.350	1.312 33.338	.1875 x .297 x .172 4.763 x 7.541 x 4.366			813	183	1,570	353	11.5	1/2 12.700
.2500 6.350	1.5625 39.688	.1875 x .297 x .172 4.763 x 7.541 x 4.366			1,230	277	2,350	528	20	5/8 15.875
.3125 7.938	1.7188 43.656	.219 x .344 x .203 5.556 x 8.731 x 5.159	.0008 20	.0008 20	1,370	308	2,740	616	26.5	3/4 19.050
.3125 7.938	2.0313 51.594	.219 x .344 x .203 5.556 x 8.731 x 5.159			1,570	353	3,140	706	41.2	1 25.400
.3750 9.525	2.5625 65.088	.281 x .406 x .266 7.144 x 10.312 x 6.747	.0010 25	.0010 25	2,500	562	5,490	1,234	84.8	1-1/4 31.750
.5000 12.700	3.0625 77.788	.344 x .500 x .328 8.731 x 12.700 x 8.334			3,430	771	8,040	1,807	143	1-1/2 38.100
.5000 12.700	3.6875 93.662	.344 x .500 x .328 8.731 x 12.700 x 8.334	.0012 30	.0012 30	6,080	1,367	15,900	3,574	399	2 50.800

The data and specifications in this publication have been carefully compiled and are believed to be accurate and correct. However, it is the responsibility of the user to determine and ensure the suitability of Pacific Bearing® products for a specific application. Pacific Bearing's only obligation will be to repair or replace without charge, any defective components if returned promptly. No liability is assumed beyond such replacement. *Consult www.pacific-bearing.com for the latest technical updates.



Simplicity® Ball Bearings

Square Flange Mount - Inch Series

Linear Motion Systems

Flange Mount

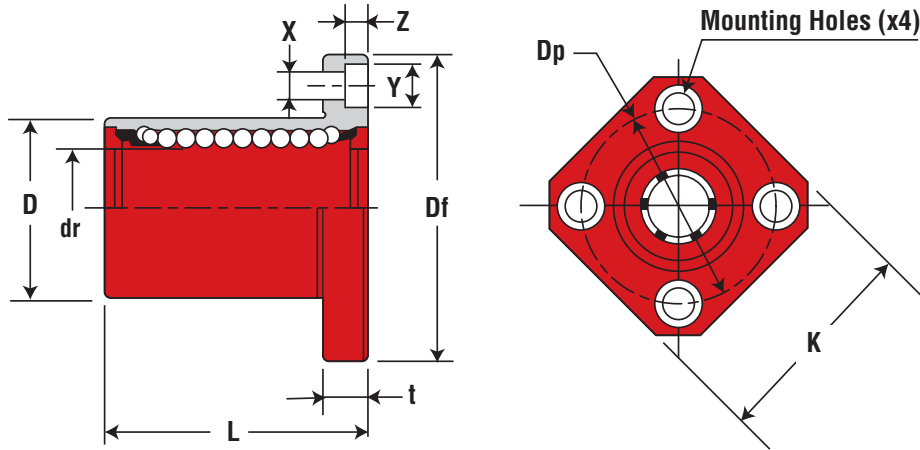

IPK SERIES - DIMENSIONAL INFORMATION

NOMINAL SHAFT DIAMETER (inch/mm)	PART NUMBER	POLYMER CAGE	BALL CIRCUIT	WEIGHT (g)	dr (inch/mm)	MAJOR DIMENSIONS & TOLERANCES					Df (inch/mm)			
						TOLERANCE (inch/ μ m)	D (inch/mm)	TOLERANCE (inch/ μ m)	L (inch/mm)	TOLERANCE (inch/mm)				
1/4 6.350	IPK4G		4	32	0/-0.0004 0/-9	0.5000 12.700	0/-0.0005 0/-13	0.7500 19.050	± 0.012 ± 0.3	1.2500 31.750				
3/8 9.525	IPK6G	47		0.3750 9.525		0.6250 15.875		0.8750 22.225		1.5000 38.100				
1/2 12.700	IPK8G	88		0.5000 12.700		0.8750 22.225		1.2500 31.750		1.7500 44.450				
5/8 15.875	IPK10G	140	0.6250 15.875	1.1250 28.575	1.5000 38.100	2.0000 50.800								
3/4 19.050	IPK12G						190	0.7500 19.050		1.2500 31.750	1.6250 41.275	2.1875 55.563		
1 25.400	IPK16G	325	5	1.0000 25.400	0/-0.0004 0/-10	1.5625 39.688	2.2500 57.150	2.5000 63.500						
1-1/4 31.750	IPK20G									665	1.2500 31.750	2.0000 50.800	2.6250 66.675	3.1250 79.375
1-1/2 38.100	IPK24G									1,100	1.5000 38.100	2.3750 60.325	3.0000 76.200	3.7500 95.250
2 50.800	IPK32G									1,760	2.0000 50.800	3.0000 76.200	4.0000 101.600	4.3750 111.125

The data and specifications in this publication have been carefully compiled and are believed to be accurate and correct. However, it is the responsibility of the user to determine and ensure the suitability of Pacific Bearing® products for a specific application. Pacific Bearing's only obligation will be to repair or replace without charge, any defective components if returned promptly. No liability is assumed beyond such replacement. *Consult www.pacific-bearing.com for the latest technical updates.



Simplicity® Ball Bearings

Square Flange Mount - Inch Series

Linear Motion Systems

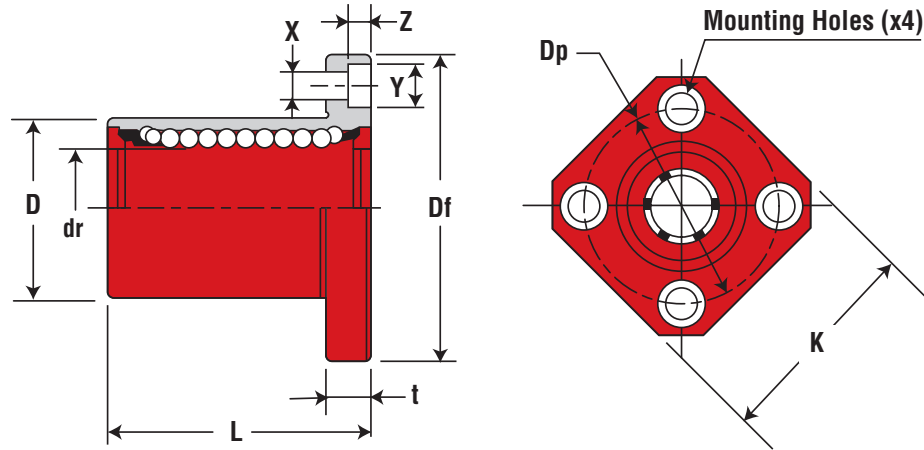

Flange Mount

IPK SERIES - DIMENSIONAL INFORMATION (cont.)

(Standard Steel Finish)

MAJOR DIMENSIONS & TOLERANCES						LOAD RATING				NOMINAL SHAFT DIAMETER (inch/mm)
K (inch/mm)	t (inch/mm)	Dp (inch/mm)	X x Y x Z (inch/mm)	ECCENTRICITY ID to OD (inch/μm)	PERPENDICULARITY FLANGE FACE to ID (inch/μm)	DYNAMIC C (N)	DYNAMIC C (lbs.)	STATIC Co (N)	STATIC Co (lbs.)	
1.0000 25.400	.2190 5.556	.8750 22.225	.156 x .250 x .141 3.969 x 6.350 x 3.572	.0005 12	.0005 12	206	46	265	60	1/4 6.350
1.2500 31.750	.2500 6.350	1.0620 26.988	.1875 x .297 x .172 4.763 x 7.541 x 4.366			225	51	314	71	3/8 9.525
1.3750 34.925		1.3120 33.338	.1875 x .297 x .172 4.763 x 7.541 x 4.366			510	115	784	176	1/2 12.700
1.5000 38.100		1.5620 39.688	.1875 x .297 x .172 4.763 x 7.541 x 4.366			774	174	1,180	265	5/8 15.875
1.6875 42.863	.3125 7.938	1.7180 43.660	.219 x .344 x .203 5.556 x 8.731 x 5.159	.0006 15	.0006 15	862	194	1,370	308	3/4 19.050
2.0000 50.800		2.0310 51.594	.219 x .344 x .203 5.556 x 8.731 x 5.159			980	220	1,570	353	1 25.400
2.5000 63.500	.3750 9.525	2.5625 65.088	.281 x .406 x .266 7.144 x 10.312 x 6.747	.0008 20	.0008 20	1,570	353	2,740	616	1-1/4 31.750
3.0000 76.200	.5000 12.700	3.0625 77.788	.344 x .500 x .328 8.731 x 12.700 x 8.334	.0010 25	.0010 25	2,180	490	4,020	904	1-1/2 38.100
3.5000 88.900		3.6875 93.662	.344 x .500 x .328 8.731 x 12.700 x 8.334			3,820	859	7,940	1,785	2 50.800

The data and specifications in this publication have been carefully compiled and are believed to be accurate and correct. However, it is the responsibility of the user to determine and ensure the suitability of Pacific Bearing® products for a specific application. Pacific Bearing's only obligation will be to repair or replace without charge, any defective components if returned promptly. No liability is assumed beyond such replacement. *Consult www.pacific-bearing.com for the latest technical updates.



Simplicity® Ball Bearings

Square Flange Mount Double Wide - Inch Series

Linear Motion Systems

Flange Mount

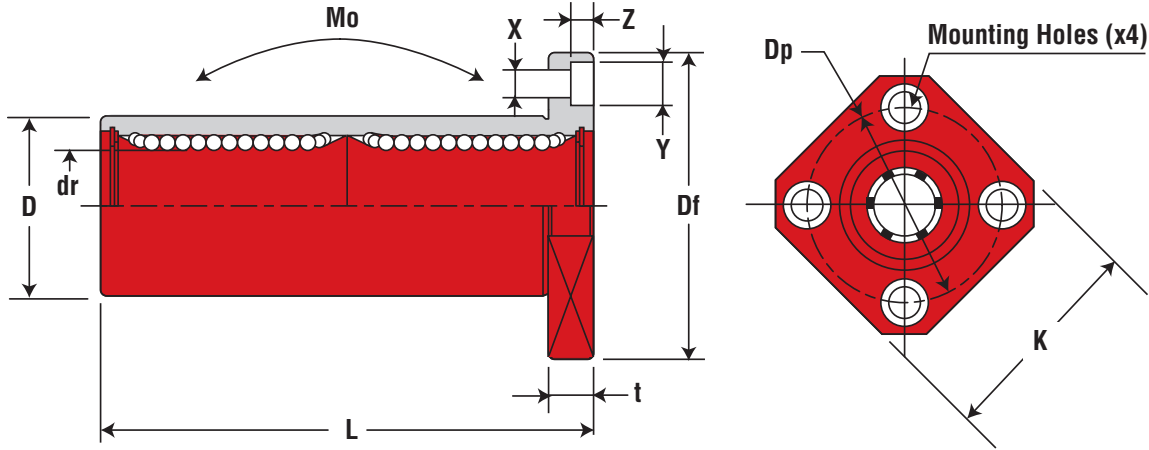

IPK-W SERIES - DIMENSIONAL INFORMATION

PART NUMBER		MAJOR DIMENSIONS & TOLERANCES								
NOMINAL SHAFT DIAMETER (inch/mm)	POLYMER CAGE	BALL CIRCUIT	WEIGHT (g)	dr (inch/mm)	TOLERANCE (inch/ μ m)	D (inch/mm)	TOLERANCE (inch/ μ m)	L (inch/mm)	TOLERANCE (inch/mm)	Df (inch/mm)
1/4 6.350	IPK4GW	4	33	0.2500 6.350	0/- .0004 0/-10	0.5000 12.700	0/- .0005 0/-13	1.3750 34.925	± 0.012 ± 0.3	1.2500 31.750
3/8 9.525	IPK6GW		45	0.3750 9.525		0.6250 15.875	0/- .00065 0/-16	1.5938 40.481		1.5000 38.100
1/2 12.700	IPK8GW		106	0.5000 12.700		0.8750 22.225		2.3750 60.325		1.7500 44.450
5/8 15.875	IPK10GW	5	200	0.6250 15.875	0/- .0005 0/-12	1.1250 28.575	2.8125 71.438	2.0000 50.800		
3/4 19.050	IPK12GW		240	0.7500 19.050		1.2500 31.750	3.0937 78.581	2.1875 55.563		
1 25.400	IPK16GW	6	470	1.0000 25.400	0/- .0006 0/-15	1.5625 39.688	4.2813 108.744	2.5000 63.500		
1-1/4 31.750	IPK20GW		935	1.2500 31.750		2.0000 50.800	5.0000 127.000	3.1250 79.375		
1-1/2 38.100	IPK24GW		1,460	1.5000 38.100		2.3750 60.325	5.6875 144.463	3.7500 95.250		
2 50.800	IPK32GW		2,620	2.0000 50.800		3.0000 76.200	7.7500 196.850	4.3750 111.125		

The data and specifications in this publication have been carefully compiled and are believed to be accurate and correct. However, it is the responsibility of the user to determine and ensure the suitability of Pacific Bearing® products for a specific application. Pacific Bearing's only obligation will be to repair or replace without charge, any defective components if returned promptly. No liability is assumed beyond such replacement. *Consult www.pacific-bearing.com for the latest technical updates.



Simplicity® Ball Bearings

Square Flange Mount Double Wide - Inch Series

Linear Motion Systems

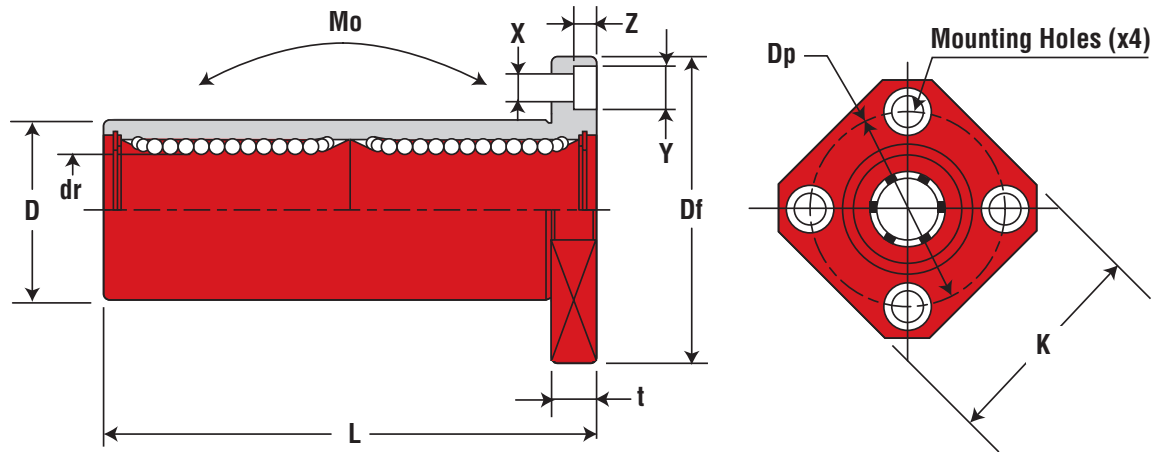

Flange Mount

IPK-W SERIES - DIMENSIONAL INFORMATION (cont.)

(Standard Steel Finish)

MAJOR DIMENSIONS & TOLERANCES						LOAD RATING					
K (inch/ mm)	t (inch/ mm)	Dp (inch/ mm)	X x Y x Z (inch/ mm)	ECCENTRICITY ID to OD (inch/ µm)	PERPENDICULARITY FLANGE FACE to ID (inch/ µm)	DYNAMIC C (N)	DYNAMIC C (lbs.)	STATIC Co (N)	STATIC Co (lbs.)	ALLOWABLE STATIC MOMENT Mo (N-m)	NOMINAL SHAFT DIAMETER (inch/ mm)
1.0000 25.400	.2190 5.556	0.8750 22.225	.156 x .250 x .141 3.969 x 6.350 x 3.572	.0006 15	.0006 15	323	73	530	119	2	1/4 6.350
1.2500 31.750	.2500 6.350	1.0620 26.988	.1875 x .297 x .172 4.763 x 7.541 x 4.366			353	79	630	142	2.7	3/8 9.525
1.3750 34.925		1.3120 33.338	.1875 x .297 x .172 4.763 x 7.541 x 4.366			813	183	1,570	353	11.5	1/2 12.700
1.5000 38.100		1.5620 39.688	.1875 x .297 x .172 4.763 x 7.541 x 4.366			1,230	277	2,350	528	20	5/8 15.875
1.6875 42.863	.3125 7.938	1.7180 43.660	.219 x .344 x .203 5.556 x 8.731 x 5.159	.0008 20	.0008 20	1,370	308	2,740	616	26.5	3/4 19.050
2.0000 50.800	2.0310 51.594	.219 x .344 x .203 5.556 x 8.731 x 5.159	1,570			353	3,140	706	41.2	1 25.400	
2.5000 63.500	.3750 9.525	2.5625 65.088	.281 x .406 x .266 7.144 x 10.312 x 6.747	.0010 25	.0010 25	2,500	562	5,490	1,234	84.8	1-1/4 31.750
3.0000 76.200	.5000 12.700	3.0625 77.788	.344 x .500 x .328 8.731 x 12.700 x 8.334			3,430	771	8,040	1,807	143	1-1/2 38.100
3.5000 88.900		3.6875 93.662	.344 x .500 x .328 8.731 x 12.700 x 8.334			6,080	1,367	15,900	3,574	399	2 50.800

The data and specifications in this publication have been carefully compiled and are believed to be accurate and correct. However, it is the responsibility of the user to determine and ensure the suitability of Pacific Bearing® products for a specific application. Pacific Bearing's only obligation will be to repair or replace without charge, any defective components if returned promptly. No liability is assumed beyond such replacement. *Consult www.pacific-bearing.com for the latest technical updates.



Simplicity® Ball Bearings

Round Flange Center Mount - Inch Series

Linear Motion Systems

Flange Mount

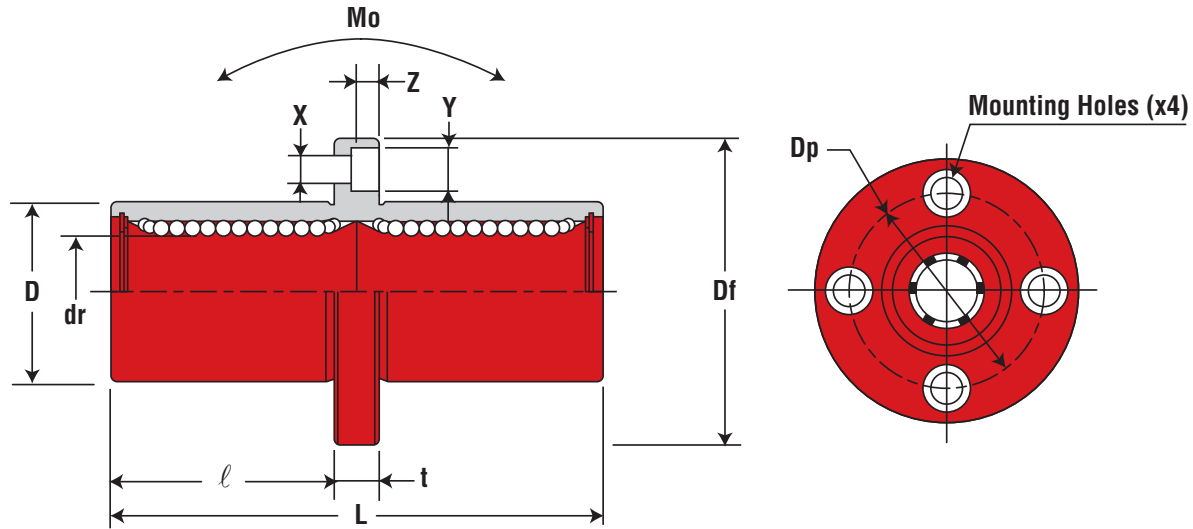

IPFC SERIES - DIMENSIONAL INFORMATION

PART NUMBER		MAJOR DIMENSIONS & TOLERANCES								
NOMINAL SHAFT DIAMETER (inch/mm)	POLYMER CAGE	BALL CIRCUIT	WEIGHT (g)	dr (inch/mm)	TOLERANCE (inch/ μ m)	D (inch/mm)	TOLERANCE (inch/ μ m)	L (inch/mm)	TOLERANCE (inch/ μ m)	ℓ (inch/mm)
1/4 6.350	IPFC4G	4	40	.2500 6.350	0/- .0004 0/-10	.5000 12.700	0/- .0005 0/-13	1.3750 34.925	± 0.012 ± 0.3	.5781 14.684
3/8 9.525	IPFC6G		60	.3750 9.525		.6250 15.875	0/- .00065 0/-16	1.5938 40.481		.6719 17.066
1/2 12.700	IPFC8G		126	.5000 12.700		.8750 22.225		2.3750 60.235		1.0625 26.988
5/8 15.875	IPFC10G	5	215	.6250 15.875	1.1250 28.575	0/- .00075 0/-19	2.8125 71.438	1.2813 32.544		
3/4 19.050	IPFC12G		280	.7500 19.050	1.2500 31.750		3.0937 78.581	1.3906 35.322		
1 25.400	IPFC16G	6	515	1.0000 25.400	1.5625 39.688	0/- .0009 0/-22	4.2813 108.744	1.9844 50.403		
1-1/4 31.750	IPFC20G		1,020	1.2500 31.750			2.0000 50.800	5.0000 127.000		2.3125 58.738
1-1/2 38.100	IPFC24G		1,630	1.5000 38.100	2.3750 60.325	5.6875 144.463	2.5938 65.882			
2 50.800	IPFC32G		2,800	2.0000 50.800	3.0000 76.200	7.7500 196.850	3.6250 92.075			

The data and specifications in this publication have been carefully compiled and are believed to be accurate and correct. However, it is the responsibility of the user to determine and ensure the suitability of Pacific Bearing® products for a specific application. Pacific Bearing's only obligation will be to repair or replace without charge, any defective components if returned promptly. No liability is assumed beyond such replacement. *Consult www.pacific-bearing.com for the latest technical updates.



Simplicity® Ball Bearings

Round Flange Center Mount - Inch Series

Linear Motion Systems

Flange Mount

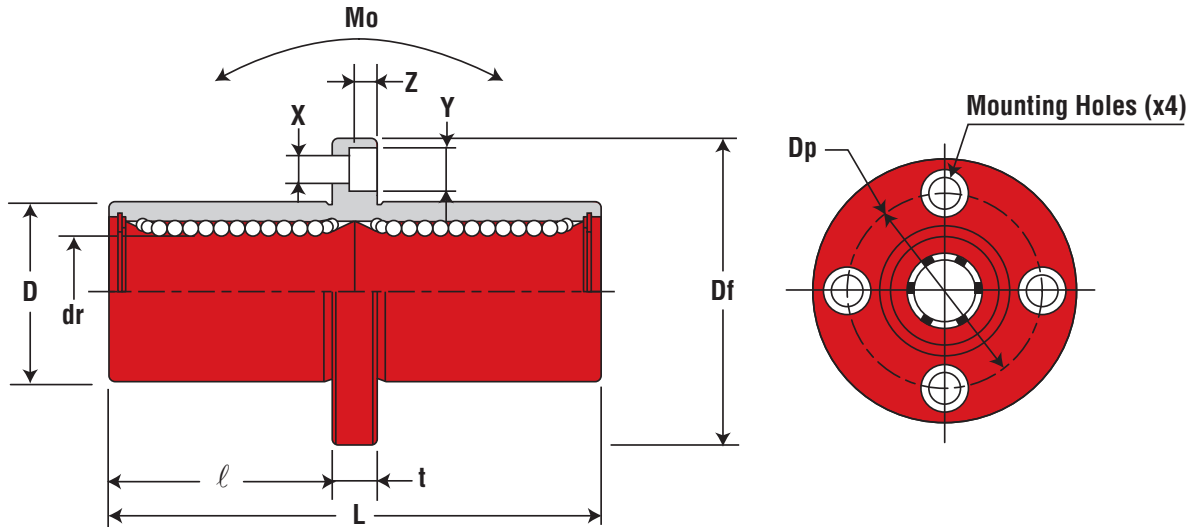

IPFC SERIES - DIMENSIONAL INFORMATION (cont.)

(Standard Steel Finish)

MAJOR DIMENSIONS & TOLERANCES						LOAD RATING					
Df (inch/ mm)	t (inch/ mm)	Dp (inch/ mm)	X x Y x Z (inch/ mm)	ECCENTRICITY ID to OD (inch/ µm)	PERPENDICULARITY FLANGE FACE to ID (inch/ µm)	DYNAMIC C (N)	DYNAMIC C (lbs.)	STATIC Co (N)	STATIC Co (lbs.)	ALLOWABLE STATIC MOMENT Mo (N-m)	NOMINAL SHAFT DIAMETER (inch/ mm)
1.2500 31.750	.2190 5.556	0.8750 22.225	.156 x .250 x .141 3.969 x 6.350 x 3.572	.0006 15	.0006 15	323	73	530	119	2.0	1/4 6.350
1.5000 38.100	.2500 6.350	1.0620 26.988	.1875 x .297 x .172 4.763 x 7.541 x 4.366			353	79	630	142	2.7	3/8 9.525
1.7500 44.450	.2500 6.350	1.3120 33.338	.1875 x .297 x .172 4.763 x 7.541 x 4.366			813	183	1,570	353	11.5	1/2 12.700
2.0000 50.800	.2500 6.350	1.5620 39.688	.1875 x .297 x .172 4.763 x 7.541 x 4.366			1,230	277	2,350	528	20.0	5/8 15.875
2.1875 55.563	.3125 7.938	1.7180 43.660	.219 x .344 x .203 5.556 x 8.731 x 5.159	.0008 20	.0008 20	1,370	308	2,740	616	26.5	3/4 19.050
2.5000 63.500	.3125 7.938	2.0310 51.594	.219 x .344 x .203 5.556 x 8.731 x 5.159			1,570	353	3,140	706	41.2	1 25.400
3.1250 79.375	.3750 9.525	2.5625 65.088	.281 x .406 x .266 7.144 x 10.312 x 6.747	.0010 25	.0010 25	2,500	562	5,490	1,234	84.8	1-1/4 31.750
3.7500 95.250	.5000 12.700	3.0625 77.788	.344 x .500 x .328 8.731 x 12.700 x 8.334			3,430	771	8,040	1,807	143	1-1/2 38.100
4.3750 111.125	.5000 12.700	3.6875 93.662	.344 x .500 x .328 8.731 x 12.700 x 8.334	.0012 30	.0012 30	6,080	1,367	15,900	3,574	399	2 50.800

The data and specifications in this publication have been carefully compiled and are believed to be accurate and correct. However, it is the responsibility of the user to determine and ensure the suitability of Pacific Bearing® products for a specific application. Pacific Bearing's only obligation will be to repair or replace without charge, any defective components if returned promptly. No liability is assumed beyond such replacement. *Consult www.pacific-bearing.com for the latest technical updates.



Simplicity® Ball Bearings

Square Flange Center Mount - Inch Series

Linear Motion Systems

Flange Mount

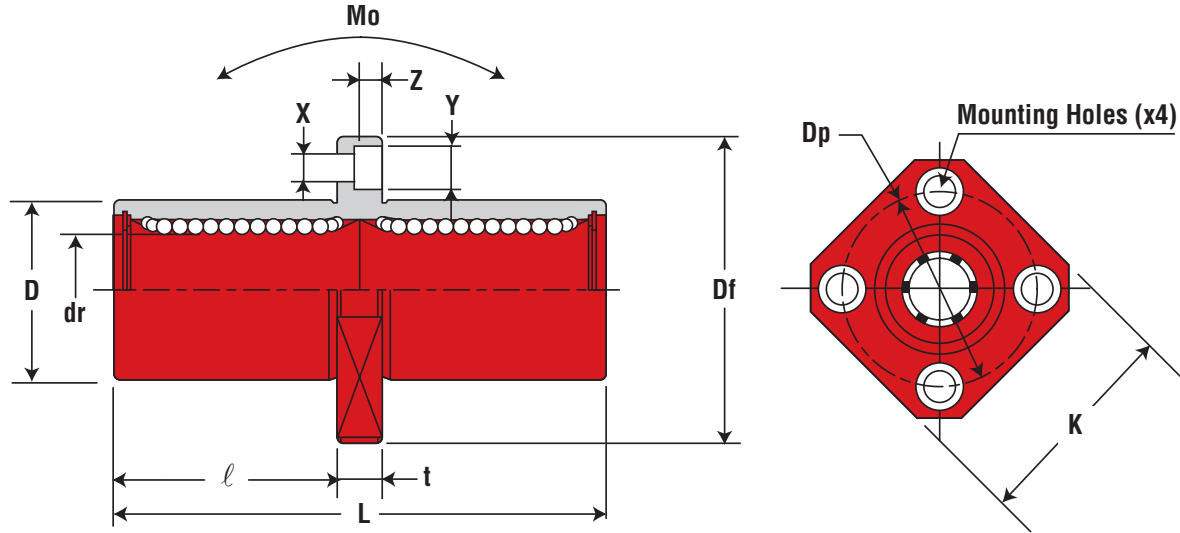

IPKC SERIES - DIMENSIONAL INFORMATION

PART NUMBER		MAJOR DIMENSIONS & TOLERANCES									
NOMINAL SHAFT DIAMETER (inch/mm)	POLYMER CAGE	BALL CIRCUIT	WEIGHT (g)	dr (inch/mm)	TOLERANCE (inch/ μ m)	D (inch/mm)	TOLERANCE (inch/ μ m)	L (inch/mm)	TOLERANCE (inch/mm)	l (inch/mm)	Df (inch/mm)
1/4 6.350	IPKC4G	4	33	0.2500 6.350	0/-0.0004 0/-10	0.5000 12.700	0/-0.0005 0/-13	1.3750 34.925	± 0.012 ± 0.3	0.5781 14.684	1.2500 31.750
3/8 9.525	IPKC6G		45	0.3750 9.525		0.6250 15.875	0/-0.00065 0/-16	1.5938 40.481		0.6719 17.066	1.5000 38.100
1/2 12.700	IPKC8G		106	0.5000 12.700		0.8750 22.225		2.3750 60.235		1.0625 26.988	1.7500 44.450
5/8 15.875	IPKC10G	5	200	0.6250 15.875	0/-0.0005 0/-12	1.1250 28.575	0/-0.00075 0/-19	2.8125 71.438		1.2813 32.544	2.0000 50.800
3/4 19.050	IPKC12G		240	0.7500 19.050		1.2500 31.750		3.0937 78.581		1.3906 35.322	2.1875 55.563
1 25.400	IPKC16G	6	470	1.0000 25.400	0/-0.0006 0/-15	1.5625 39.688	0/-0.0009 0/-22	4.2813 108.744		1.9800 50.403	2.5000 63.500
1-1/4 31.750	IPKC20G		935	1.2500 31.750		2.0000 50.800		5.0000 127.000		2.3125 58.738	3.1250 79.375
1-1/2 38.100	IPKC24G		1,460	1.5000 38.100		2.3750 60.325		5.6875 144.463		2.5938 65.882	3.7500 95.250
2 50.800	IPKC32G		2,620	2.0000 50.800		3.0000 76.200		7.7500 196.850	3.6250 92.075	4.3750 111.125	

The data and specifications in this publication have been carefully compiled and are believed to be accurate and correct. However, it is the responsibility of the user to determine and ensure the suitability of Pacific Bearing® products for a specific application. Pacific Bearing's only obligation will be to repair or replace without charge, any defective components if returned promptly. No liability is assumed beyond such replacement. *Consult www.pacific-bearing.com for the latest technical updates.



Simplicity® Ball Bearings

Square Flange Center Mount - Inch Series

Linear Motion Systems

Flange Mount

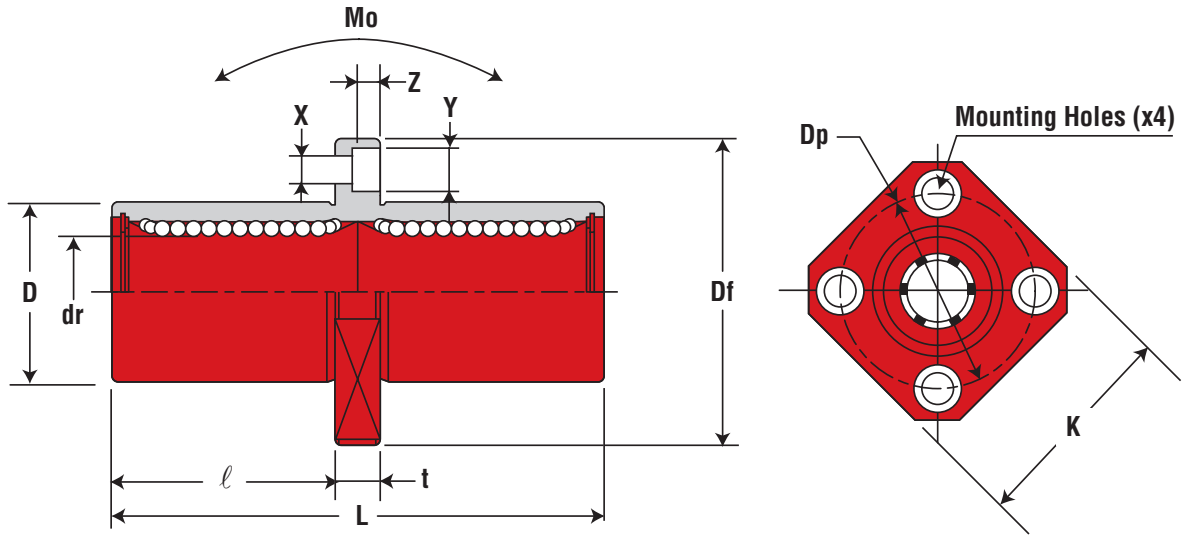

IPKC SERIES - DIMENSIONAL INFORMATION (cont.)

(Standard Steel Finish)

MAJOR DIMENSIONS & TOLERANCES						LOAD RATING					NOMINAL SHAFT DIAMETER (inch/mm)
K (inch/mm)	t (inch/mm)	Dp (inch/mm)	X x Y x Z (inch/mm)	ECCENTRICITY ID to OD (inch/ μ m)	PERPENDICULARITY FLANGE FACE to ID (inch/ μ m)	DYNAMIC C (N)	DYNAMIC C (lbs.)	STATIC Co (N)	STATIC Co (lbs.)	ALLOWABLE STATIC MOMENT Mo (N-m)	
1.0000 25.400	.2190 5.556	0.8750 22.225	.156 x .250 x .141 3.969 x 6.350 x 3.572	.0006 15	.0006 15	323	73	530	119	2.0	1/4 6.350
1.2500 31.750	.2500 6.350	1.0620 26.988	.1875 x .297 x .172 4.763 x 7.541 x 4.366			353	79	630	142	2.7	3/8 9.525
1.3750 34.925		1.3120 33.338	.1875 x .297 x .172 4.763 x 7.541 x 4.366			813	183	1,570	353	11.5	1/2 12.700
1.5000 38.100		1.5620 39.688	.1875 x .297 x .172 4.763 x 7.541 x 4.366			1,230	277	2,350	528	20.0	5/8 15.875
1.6875 42.863	.3125 7.938	1.7180 43.660	.219 x .344 x .203 5.556 x 8.731 x 5.159	.0008 20	.0008 20	1,370	308	2,740	6162	26.5	3/4 19.050
2.0000 50.800		2.0310 51.594	.219 x .344 x .203 5.556 x 8.731 x 5.159			1,570	353	3,140	706	41.2	1 25.400
2.5000 63.500	.3750 9.525	2.5625 65.088	.281 x .406 x .266 7.144 x 10.312 x 6.747	.0010 25	.0010 25	2,500	562	5,490	1,234	84.8	1-1/4 31.750
3.0000 76.200	.5000 12.700	3.0625 77.788	.344 x .500 x .328 8.731 x 12.700 x 8.334			3,430	771	8,040	1,807	143	1-1/2 38.100
3.5000 88.900		3.6875 93.662	.344 x .500 x .328 8.731 x 12.700 x 8.334			.0012 30	.0012 30	6,080	1,367	15,900	3,574

The data and specifications in this publication have been carefully compiled and are believed to be accurate and correct. However, it is the responsibility of the user to determine and ensure the suitability of Pacific Bearing® products for a specific application. Pacific Bearing's only obligation will be to repair or replace without charge, any defective components if returned promptly. No liability is assumed beyond such replacement. *Consult www.pacific-bearing.com for the latest technical updates.



Simplicity® Ball Bearings

Pillow Blocks - Inch Series

Linear Motion Systems

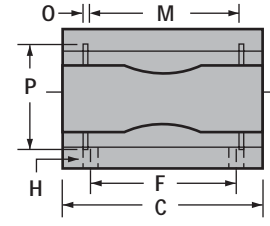
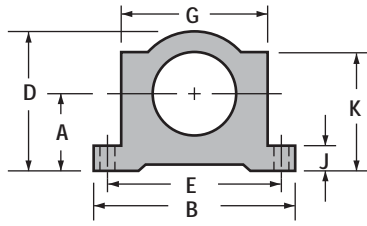
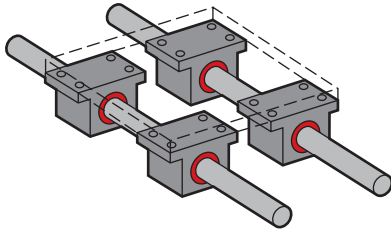

Pillow Blocks

CLOSED PILLOW BLOCKS

PART NO. CLOSED	NOM. BRG. I.D.	A	B	C	D	E	F	G	H		J	K	M	O	P	SMALLEY RET. RING PART NO.	ASSEM. WT. (lbs.)
									BOLT	HOLE							
PRECISION	MIN.	CENTERLINE +/- .001	WIDTH	LENGTH	HEIGHT	+/- .010	+/- .010	BODY WIDTH			FLNG. THICK		GRV. SPACE	GRV. WIDTH	GRV. DIA.		
IPP04G	1/4"	0.437	1.625	1.19	0.813	1.3120	0.7500	1.000	#6	5/32"	0.188	0.750	0.750	0.039	0.532	WH-51	0.099
IPP06G	3/8"	0.500	1.750	1.31	0.938	1.4370	0.8750	1.125			0.188	0.875	0.875	0.039	0.665	WH-65	0.129
IPP08G	1/2"	0.687	2.000	1.69	1.250	1.6880	1.0000	1.375			0.250	1.125	1.250	0.046	0.931	WH-90	0.250
IPP10G	5/8"	0.875	2.500	1.94	1.625	2.1250	1.1250	1.750	#8	3/16"	0.281	1.438	1.500	0.056	1.197	WH-115	0.500
IPP12G	3/4"	0.937	2.750	2.06	1.750	2.3750	1.2500	1.875			0.313	1.563	1.625	0.056	1.330	WH-128	0.580
IPP16G	1"	1.187	3.250	2.81	2.188	2.8750	1.7500	2.375	#10	7/32"	0.375	1.938	2.250	0.068	1.671	WH-156	1.000
IPP20G	1-1/4"	1.500	4.000	3.63	2.813	3.5000	2.0000	3.000			0.438	2.500	2.625	0.068	2.122	WH-200	2.000
IPP24G	1-1/2"	1.750	4.750	4.00	3.250	4.1250	2.5000	3.500	1/4"	9/32"	0.500	2.875	3.000	0.086	2.519	WH-237	3.000
IPP32G	2"	2.125	6.000	5.00	4.063	5.2500	3.2500	4.500	3/8"	13/32"	0.625	3.625	4.000	0.103	3.182	WH-300	6.500

- NOTES: (1) Standard, pre-assembled pillow blocks include self-aligning housing and precision bearing.
 (2) All standard pillow blocks use standard "IP" series bearings found on page 70.
 (3) Straight bore, pre-assembled pillow blocks use standard "IP" series bearing.

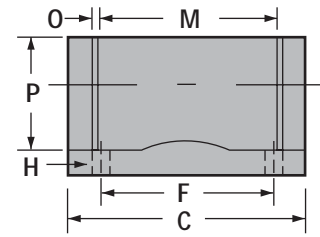
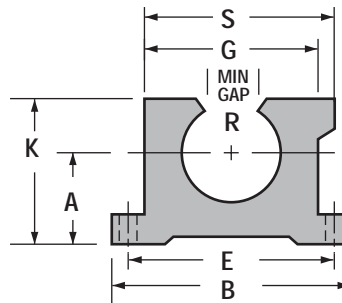
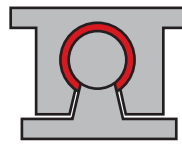
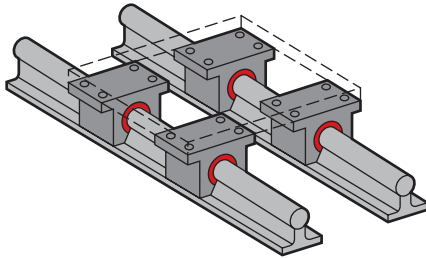

OPEN PILLOW BLOCKS

PART NO. CLOSED	NOM. BRG. I.D.	A	B	C	E	F	G	H		J	K	M	O	P	R	EATON RET. RING PART NO.	ASSEM. WT. (lbs.)	S
								BOLT	HOLE									
PRECISION	MIN.	CENTERLINE +/- .001	WIDTH +/- .010	LENGTH	+/- .010	+/- .010	BODY WIDTH			FLNG THICK	HEIGHT	GRV. SPACE	GRV. WIDTH	GRV. DIA.	MIN. OPEN			
IPPN08G	1/2"	0.687	2.000	1.50	1.6880	1.0000	1.375	#6	5/32"	0.250	1.125	1.250	0.046	0.931	0.313	MNAN-87	0.250	1.438
IPPN10G	5/8"	0.875	2.500	1.75	2.1250	1.1250	1.750			#8	3/16"	0.281	1.438	1.500	0.056	1.197	0.375	MNAN-112
IPPN12G	3/4"	0.937	2.750	1.88	2.3750	1.2500	1.875	#10	7/32"			0.313	1.563	1.625	0.056	1.330	0.438	MNAN-125
IPPN16G	1"	1.187	3.250	2.63	2.8750	1.7500	2.375			#10	7/32"	0.375	1.938	2.250	0.068	1.671	0.563	MNAN-156
IPPN20G	1-1/4"	1.500	4.000	3.38	3.5000	2.0000	3.000	1/4"	9/32"			0.438	2.500	2.625	0.068	2.122	0.625	MNAN-200
IPPN24G	1-1/2"	1.750	4.750	3.75	4.1250	2.5000	3.500			3/8"	13/32"	0.500	2.875	3.000	0.086	2.519	0.750	MNAN-237
IPPN32G	2"	2.125	6.000	4.75	5.2500	3.2500	4.500					0.625	3.625	4.000	0.103	3.182	1.000	MNAN-300

- NOTES: (1) Standard, pre-assembled pillow blocks include self-aligning housing and precision bearing.
 (2) All standard pillow blocks use standard "IP" series bearings found on page 70.
 (3) All open pillow blocks have "notch".

The data and specifications in this publication have been carefully compiled and are believed to be accurate and correct. However, it is the responsibility of the user to determine and ensure the suitability of Pacific Bearing® products for a specific application. Pacific Bearing's only obligation will be to repair or replace without charge, any defective components if returned promptly. No liability is assumed beyond such replacement. *Consult www.pacific-bearing.com for the latest technical updates.

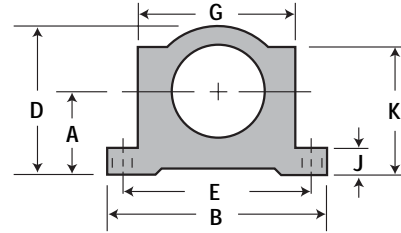
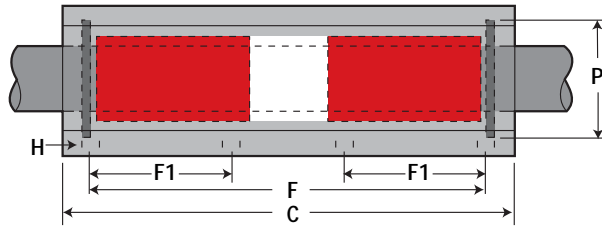

TWIN CLOSED PILLOW BLOCKS

PART NO. CLOSED	NOM. BRG. I.D.	A CENTERLINE	B WIDTH	C LENGTH	D HEIGHT	E +/- .010	F +/- .010	F1 +/- .010	G BODY WIDTH	H		J THICK	K HEIGHT	P GRV. DIA	SMALLEY RET. RING PART NO.	ASSEM. WT. (lbs.)
										BOLT	HOLE					
IPPW04G	1/4"	0.437	1.625	2.500	0.813	1.3120	2.0000	.750	1.000	#6	5/32"	0.188	0.750	0.532	WH-51	0.197
IPPW06G	3/8"	0.500	1.750	2.750	0.938	1.4370	2.2500	.875	1.125			0.188	0.875	0.665	WH-65	0.258
IPPW08G	1/2"	0.687	2.000	3.500	1.250	1.6880	2.5000	1.000	1.375			0.250	1.125	0.931	WH-90	0.500
IPPW10G	5/8"	0.875	2.500	4.000	1.625	2.1250	3.0000	1.125	1.750	#8	3/16"	0.281	1.438	1.197	WH-115	1.000
IPPW12G	3/4"	0.937	2.750	4.500	1.750	2.3750	3.5000	1.250	1.875			0.313	1.563	1.330	WH-128	1.125
IPPW16G	1"	1.187	3.250	6.000	2.188	2.8750	4.5000	1.750	2.375	#10	7/32"	0.375	1.938	1.671	WH-156	2.188
IPPW20G	1-1/4"	1.500	4.000	7.500	2.813	3.5000	5.5000	2.000	3.000			0.438	2.500	2.122	WH-200	4.250
IPPW24G	1-1/2"	1.750	4.750	9.000	3.250	4.1250	6.5000	2.500	3.500	1/4"	9/32"	0.500	2.875	2.519	WH-237	6.375
IPPW32G	2"	2.125	6.000	10.000	4.063	5.2500	8.2500	3.250	4.500	3/8"	13/32"	0.625	3.625	3.182	WH-300	13.500

- NOTES: (1) All standard pillow blocks use standard "IP" series bearings found on page 70.
 (2) Twin Closed Pillow Blocks are non-self-aligning

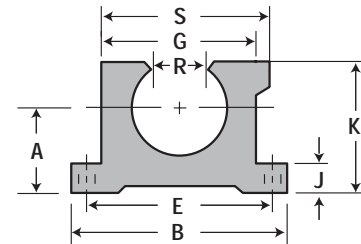
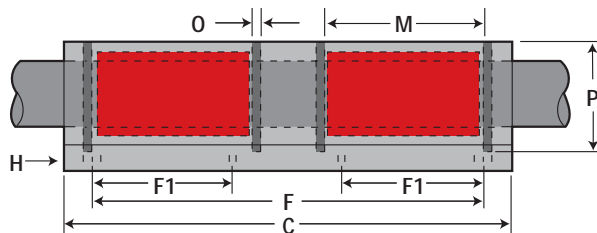

TWIN OPEN PILLOW BLOCKS

PART NO. OPEN	NOM. BRG. I.D.	A CENTERLINE +/- .001	B WIDTH	C LENGTH	E +/- .010	F +/- .010	F1 +/- .010	G BODY WIDTH	H		J FLNG. THICK	K HEIGHT	M GRV. SPACE	O GRV. WIDE	P GRV. DIA.	R MIN. OPEN	EATON RET. RING PART NO.	ASSEM. WT. (lbs.)	S OVERALL WIDTH		
									BOLT	HOLE											
IPPWN08G	1/2"	0.687	2.000	3.500	1.6880	2.5000	1.000	1.375	#6	5/32"	0.250	1.125	1.250	0.046	0.931	0.313	MNAN-87	0.400	1.438		
IPPWN10G	5/8"	0.875	2.500	4.000	2.1250	3.0000	1.125	1.750			#8	3/16"	0.281	1.438	1.500	0.056	1.197	0.375	MNAN-112	0.910	1.813
IPPWN12G	3/4"	0.937	2.750	4.500	2.3750	3.5000	1.250	1.875					0.313	1.563	1.625	0.056	1.330	0.438	MNAN-125	1.060	1.938
IPPWN16G	1"	1.187	3.250	6.000	2.8750	4.5000	1.750	2.375	#10	7/32"	0.375	1.938	2.250	0.068	1.671	0.563	MNAN-156	1.970	2.438		
IPPWN20G	1-1/4"	1.500	4.000	7.500	3.5000	5.5000	2.000	3.000			0.438	2.500	2.625	0.068	2.122	0.625	MNAN-200	3.725	3.125		
IPPWN24G	1-1/2"	1.750	4.750	9.000	4.1250	6.5000	2.500	3.500	1/4"	9/32"	0.500	2.875	3.000	0.086	2.519	0.750	MNAN-237	5.800	3.625		
IPPWN32G	2"	2.125	6.000	10.000	5.2500	8.2500	3.250	4.500	3/8"	13/32"	0.625	3.625	4.000	0.103	3.182	1.000	MNAN-300	12.125	4.688		

- NOTES: (1) All standard pillow blocks use standard "IP" series bearings found on page 70.
 (2) All open pillow blocks have "notch".

The data and specifications in this publication have been carefully compiled and are believed to be accurate and correct. However, it is the responsibility of the user to determine and ensure the suitability of Pacific Bearing® products for a specific application. Pacific Bearing's only obligation will be to repair or replace without charge, any defective components if returned promptly. No liability is assumed beyond such replacement. *Consult www.pacific-bearing.com for the latest technical updates.



Simplicity® Ball Bearings

Linear Ball Bearings - ISO Metric

Linear Motion Systems

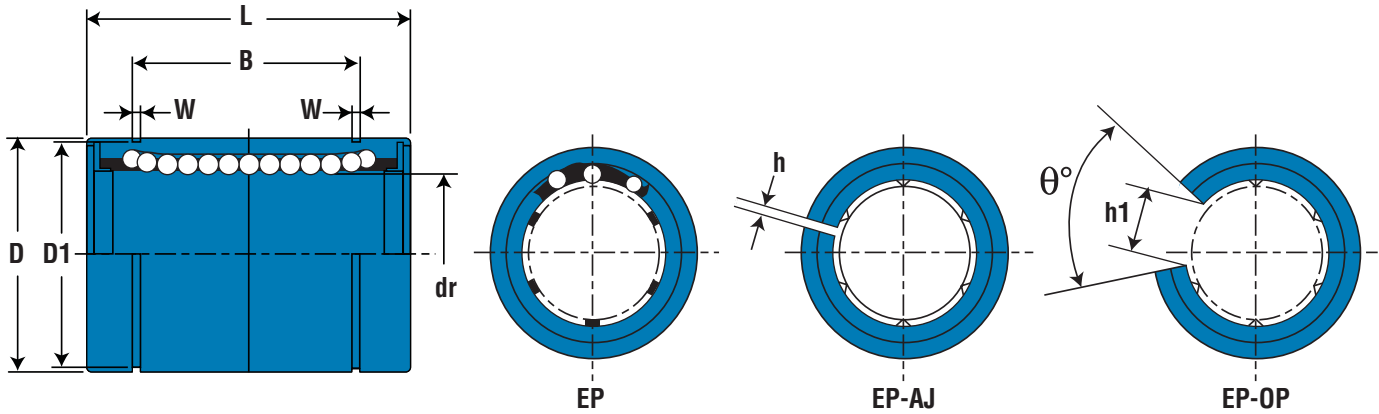

EP SERIES - DIMENSIONAL INFORMATION

NOMINAL SHAFT DIAMETER (mm)	PART NUMBER					MAJOR DIMENSIONS & TOLERANCES					
	STANDARD CLOSE POLYMER CAGE	BALL CIRCUIT	WEIGHT (g)	STANDARD OPEN POLYMER CAGE	ADJUSTABLE POLYMER CAGE	dr (mm)	TOLERANCE (µm)	D (mm)	TOLERANCE (µm)	L (mm)	TOLERANCE (mm)
5	EP5G	4	11	-	-	5	+8 0	12	0 -8	22	0 -0.2
8	EP8G		20	-	-	8		16		25	
10	EP10G		36	-	-	10		19		29	
12	EP12G		41	EP12G-OP	EP12G-AJ	12		22		32	
16	EP16G	5	65	EP16G-OP	EP16G-AJ	16	+9 -1	26	0 -9	36	0 -0.3
20	EP20G		91	EP20G-OP	EP20G-AJ	20		32		45	
25	EP25G	6	215	EP25G-OP	EP25G-AJ	25	+11 -1	40	0 -11	58	0 -0.3
30	EP30G		325	EP30G-OP	EP30G-AJ	30		47		68	
40	EP40G		705	EP40G-OP	EP40G-AJ	40	+13 -2	62	0 -13	80	
50	EP50G		1,130	EP50G-OP	EP50G-AJ	50		75		100	
60	EP60G		2,220	EP60G-OP	EP60G-AJ	60		90		125	

The data and specifications in this publication have been carefully compiled and are believed to be accurate and correct. However, it is the responsibility of the user to determine and ensure the suitability of Pacific Bearing® products for a specific application. Pacific Bearing's only obligation will be to repair or replace without charge, any defective components if returned promptly. No liability is assumed beyond such replacement. *Consult www.pacific-bearing.com for the latest technical updates.



Simplicity® Ball Bearings

Linear Ball Bearings - ISO Metric

Linear Motion Systems

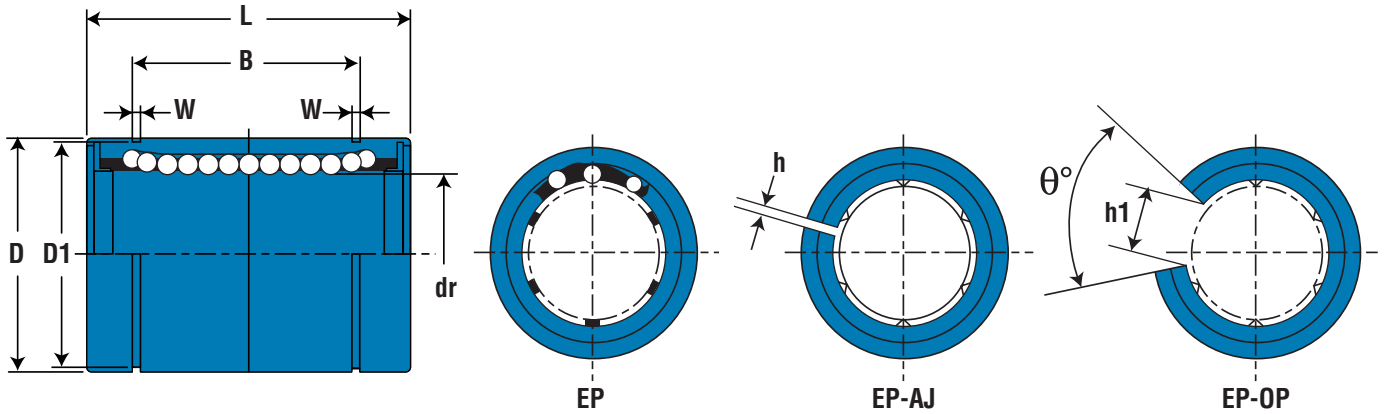

EP SERIES - DIMENSIONAL INFORMATION (cont.)

(Standard Steel Finish)

MAJOR DIMENSIONS & TOLERANCES											LOAD RATING					
B (mm)	TOLERANCE (mm)	W (mm)	TOLERANCE (mm)	D1 (mm)	TOLERANCE (mm)	h (mm)	h1 (mm)	θ°	ECCENTRICITY (μm)	MAX RADIAL CLEARANCE (μm)	DYNAMIC C (N)	STATIC Co (N)	NOMINAL SHAFT DIAMETER (mm)			
14.5	0 -0.3	1.1	+0.14 0	11.5	0 -0.11	1	-	-	12	-5	206	265	5			
16.5		1.1		15.2			-	-			265	402	8			
22		1.3		18			6.8	80			372	549	10			
22.9		1.3		21	0 -0.13	1.5	7.5	78			-7	510	784	12		
24.9		1.3		24.9	0 -0.21		10					774	1,180	16		
31.5	0 -0.4	1.6		30.3	0 -0.25	2	10	60	15	-9	882	1,370	20			
44.1		1.85		37.5			12.5				980	1,570	25			
52.1		1.85		44.5			12.5				1,570	2,740	30			
60.6		2.15		59	0 -0.30	3	16.8				50	17	-13	2,160	4,020	40
77.6		2.65		72	21		3,820							7,940	50	
101.7	3.15	86.5	0 -0.35	27.2	54	20	-16	4,700	10,000	60						

The data and specifications in this publication have been carefully compiled and are believed to be accurate and correct. However, it is the responsibility of the user to determine and ensure the suitability of Pacific Bearing® products for a specific application. Pacific Bearing's only obligation will be to repair or replace without charge, any defective components if returned promptly. No liability is assumed beyond such replacement. *Consult www.pacific-bearing.com for the latest technical updates.



Simplicity® Ball Bearings

Double Wide Linear Ball Bearings - ISO Metric

Linear Motion Systems

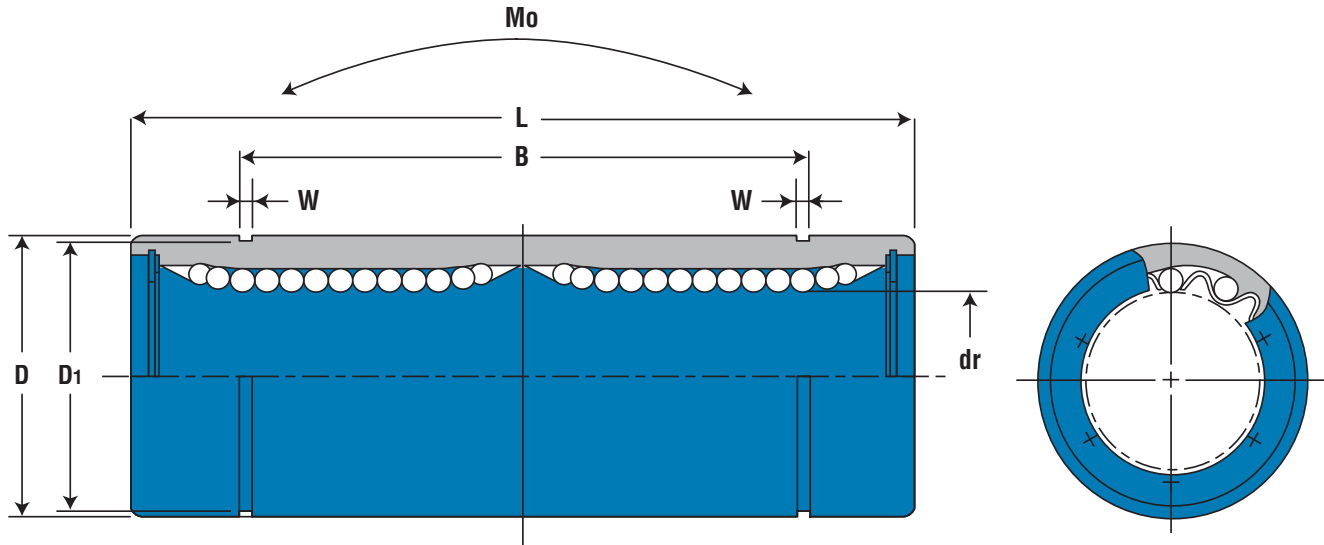

Ball Bearings

EP-W SERIES - DIMENSIONAL INFORMATION

NOMINAL SHAFT DIAMETER (mm)	PART NUMBER	MAJOR DIMENSIONS & TOLERANCES							
		BALL CIRCUIT	WEIGHT (g)	dr (mm)	TOLERANCE (µm)	D (mm)	TOLERANCE (µm)	L (mm)	TOLERANCE (mm)
8	EP8GW	4	40	8	+9 -1	16	0 -9	46	0 -0.3
12	EP12GW		80	12		22		61	
16	EP16GW	5	115	16	+11 -1	26	68		
20	EP20GW		180	20		32	80		
25	EP25GW	6	430	25	+13 -2	40	0 -13	112	0 -0.4
30	EP30GW		615	30		47		123	
40	EP40GW		1,400	40		62		151	
50	EP50GW	2,320	50	+16 -4	75	0 -20	192		
60	EP60GW	3,920	60		90		209		

The data and specifications in this publication have been carefully compiled and are believed to be accurate and correct. However, it is the responsibility of the user to determine and ensure the suitability of Pacific Bearing® products for a specific application. Pacific Bearing's only obligation will be to repair or replace without charge, any defective components if returned promptly. No liability is assumed beyond such replacement. *Consult www.pacific-bearing.com for the latest technical updates.



Simplicity® Ball Bearings

Double Wide Linear Ball Bearings - ISO Metric

Linear Motion Systems

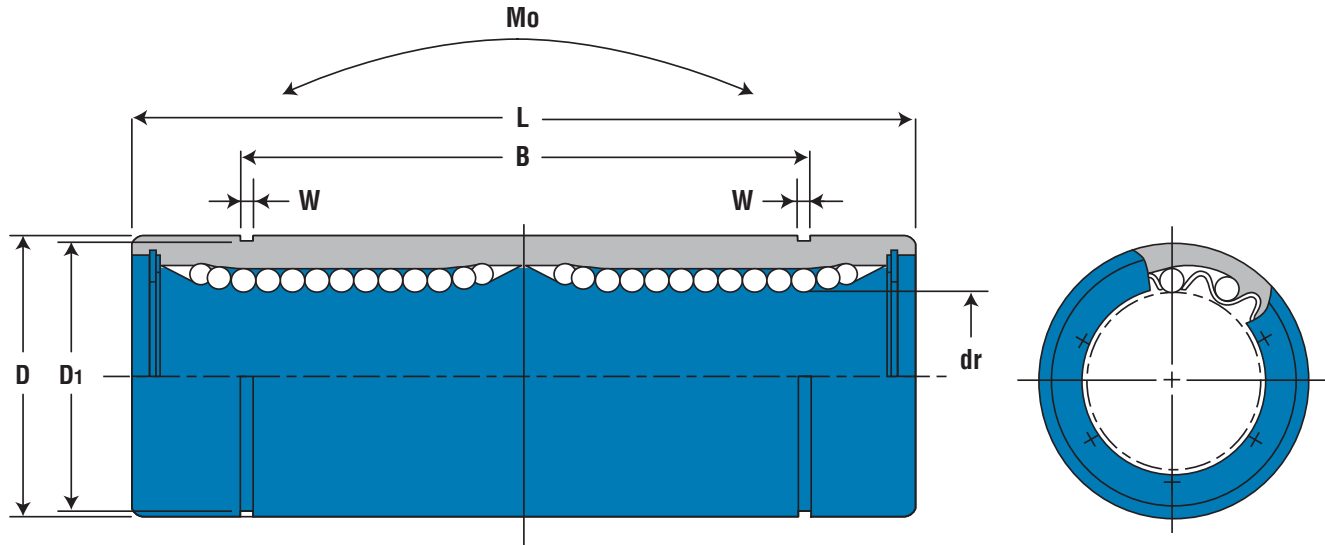

EP-W SERIES - DIMENSIONAL INFORMATION (cont.)

(Standard Steel Finish)

MAJOR DIMENSIONS & TOLERANCES							LOAD RATING			
B (mm)	TOLERANCE (mm)	W (mm)	TOLERANCE (mm)	D1 (mm)	TOLERANCE (mm)	ECCENTRICITY (µm)	DYNAMIC C (N)	STATIC Co (N)	ALLOWABLE STATIC MOMENT Mo (N-m)	NOMINAL SHAFT DIAMETER (mm)
33	0 -0.3	1.1	+0.14 0	15.2	0 -0.11	15	421	804	4.3	8
45.8		1.3		21	0 -0.13		813	1,570	11.7	12
49.8		1.3		24.9	0 -0.21		921	1,780	14.2	16
61	0 -0.4	1.6	+0.14 0	30.3	0 -0.25	17	1,370	2,740	25	20
82		1.85		37.5			0 -0.25	1,570	3,140	44
104.2		1.85		44.5	0 -0.30	20	2,500	5,490	78.9	30
121.2		2.15		59			3,430	8,040	147	40
155.2		2.65		72			6,080	15,900	396	50
170	3.15	86.5	0 -0.35	25	7,550	20,000	487	60		

The data and specifications in this publication have been carefully compiled and are believed to be accurate and correct. However, it is the responsibility of the user to determine and ensure the suitability of Pacific Bearing® products for a specific application. Pacific Bearing's only obligation will be to repair or replace without charge, any defective components if returned promptly. No liability is assumed beyond such replacement. *Consult www.pacific-bearing.com for the latest technical updates.



Simplicity® Ball Bearings

Round Flange Mount - ISO Metric

Linear Motion Systems

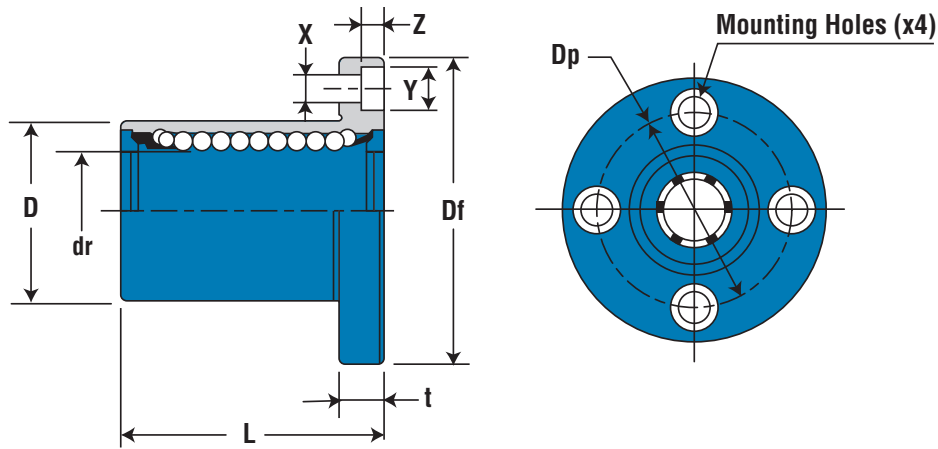

Flange Mount

EPF SERIES - DIMENSIONAL INFORMATION

NOMINAL SHAFT DIAMETER (mm)	PART NUMBER	MAJOR DIMENSIONS & TOLERANCES							
		BALL CIRCUIT	WEIGHT (g)	dr (mm)	TOLERANCE (µm)	D (mm)	TOLERANCE (µm)	L (mm)	TOLERANCE (mm)
8	EPF8G	4	41	8	+8 0	16	0 -13	25	± 0.3
12	EPF12G		80	12		22	0 -16	32	
16	EPF16G	5	103	16	+9 -1	26	0 -19	36	
20	EPF20G		182	20		32		45	
25	EPF25G	6	335	25	+11 -1	40	0 -22	58	
30	EPF30G		560	30		47		68	
40	EPF40G	6	1,175	40	+13 -2	62	0 -25	80	
50	EPF50G		1,745	50		75		100	
60	EPF60G		3,220	60		90		125	

The data and specifications in this publication have been carefully compiled and are believed to be accurate and correct. However, it is the responsibility of the user to determine and ensure the suitability of Pacific Bearing® products for a specific application. Pacific Bearing's only obligation will be to repair or replace without charge, any defective components if returned promptly. No liability is assumed beyond such replacement. *Consult www.pacific-bearing.com for the latest technical updates.



Simplicity® Ball Bearings

Round Flange Mount - ISO Metric

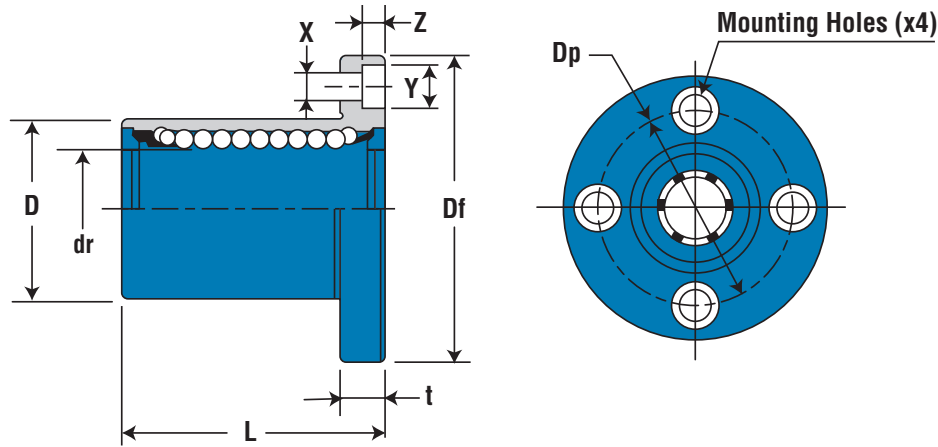

EPF SERIES - DIMENSIONAL INFORMATION (cont.)

(Standard Steel Finish)

MAJOR DIMENSIONS & TOLERANCES						LOAD RATING		NOMINAL SHAFT DIAMETER (mm)
Df (mm)	t (mm)	Dp (mm)	X x Y x Z (mm)	ECCENTRICITY ID to OD (inch/ μ m)	PERPENDICULARITY FLANGE FACE to ID (inch/ μ m)	DYNAMIC C (N)	STATIC Co (N)	
32	5	24	3.5 x 6.0 x 3.1	12	12	265	402	8
42	6	32	4.5 x 7.5 x 4.1			510	784	12
46		36	4.5 x 7.5 x 4.1			578	892	16
54	8	43	5.5 x 9.0 x 5.1	15	15	862	1,370	20
62		51	5.5 x 9.0 x 5.1			980	1,570	25
76	10	62	6.6 x 11.0 x 6.1			1,570	2,740	30
98	13	80	9.0 x 14.0 x 8.1	17	17	2,160	4,020	40
112		94	9.0 x 14.0 x 8.1			3,820	7,940	50
134	18	112	11.0 x 17.0 x 11.1	20	20	4,700	9,800	60

The data and specifications in this publication have been carefully compiled and are believed to be accurate and correct. However, it is the responsibility of the user to determine and ensure the suitability of Pacific Bearing® products for a specific application. Pacific Bearing's only obligation will be to repair or replace without charge, any defective components if returned promptly. No liability is assumed beyond such replacement. *Consult www.pacific-bearing.com for the latest technical updates.



Simplicity® Ball Bearings

Round Flange Mount Double Wide - ISO Metric

Linear Motion Systems

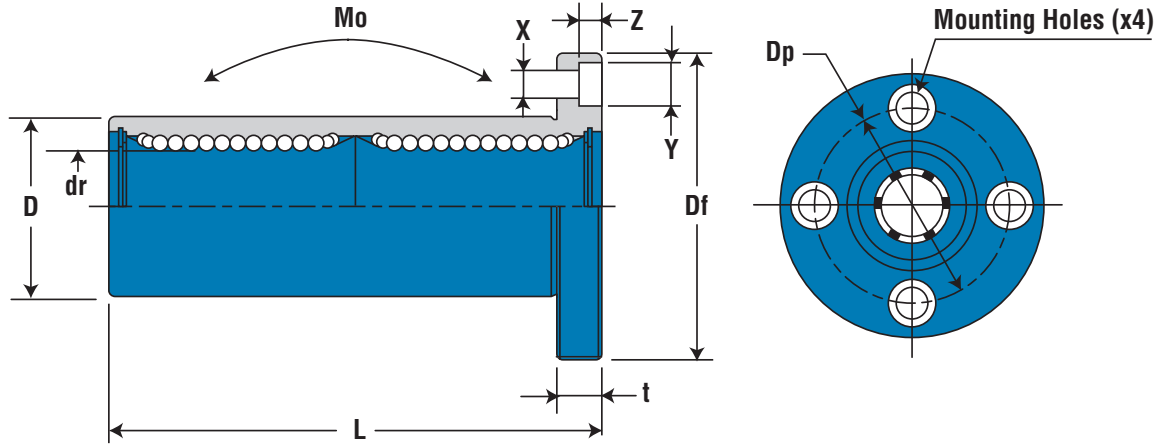

Flange Mount

EPF-W SERIES - DIMENSIONAL INFORMATION

NOMINAL SHAFT DIAMETER (mm)	PART NUMBER	MAJOR DIMENSIONS & TOLERANCES							
		BALL CIRCUIT	WEIGHT (g)	dr (mm)	TOLERANCE (µm)	D (mm)	TOLERANCE (µm)	L (mm)	TOLERANCE (mm)
8	EPF8GW	4	59	8	+9 -1	16	0 -13	46	± 0.3
12	EPF12GW		110	12		22		61	
16	EPF16GW	5	160	16	+11 -1	26	0 -16	68	
20	EPF20GW		260	20		32		80	
25	EPF25GW	6	540	25	+13 -2	40	0 -19	112	
30	EPF30GW		815	30		47		123	
40	EPF40GW	6	1,805	40	+16 -4	62	0 -22	151	
50	EPF50GW		2,820	50		75		192	
60	EPF60GW		4,920	60		90		209	

The data and specifications in this publication have been carefully compiled and are believed to be accurate and correct. However, it is the responsibility of the user to determine and ensure the suitability of Pacific Bearing® products for a specific application. Pacific Bearing's only obligation will be to repair or replace without charge, any defective components if returned promptly. No liability is assumed beyond such replacement. *Consult www.pacific-bearing.com for the latest technical updates.



Simplicity® Ball Bearings

Round Flange Mount Double Wide - ISO Metric

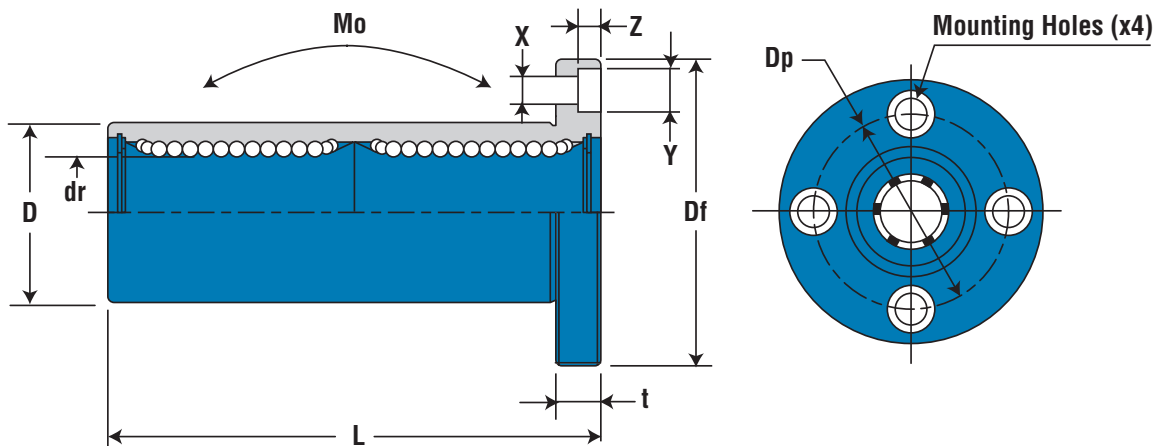

EPF-W SERIES - DIMENSIONAL INFORMATION (cont.)

(Standard Steel Finish)

MAJOR DIMENSIONS & TOLERANCES						LOAD RATING			
Df (mm)	t (mm)	Dp (mm)	X x Y x Z (mm)	ECCENTRICITY ID to OD (inch/ μ m)	PERPENDICULARITY FLANGE FACE to ID (inch/ μ m)	DYNAMIC C (N)	STATIC Co (N)	ALLOWABLE STATIC MOMENT Mo (N-m)	NOMINAL SHAFT DIAMETER (mm)
32	5	24	3.5 x 6.0 x 3.1	15	15	421	804	4.3	8
42	6	32	4.5 x 7.5 x 4.1			813	1,570	11.7	12
46		36	4.5 x 7.5 x 4.1			921	1,780	14.2	16
54	8	43	5.5 x 9.0 x 5.1	17	17	1,370	2,740	25	20
62		51	5.5 x 9.0 x 5.1			1,570	3,140	44	25
76	10	62	6.6 x 11.0 x 6.1			2,500	5,490	78.9	30
98	13	80	9.0 x 14.0 x 8.1	20	20	3,430	8,040	147	40
112		94	9.0 x 14.0 x 8.1			6,080	15,900	396	50
134	18	112	11.0 x 17.0 x 11.1	25	25	7,550	20,000	487	60

The data and specifications in this publication have been carefully compiled and are believed to be accurate and correct. However, it is the responsibility of the user to determine and ensure the suitability of Pacific Bearing® products for a specific application. Pacific Bearing's only obligation will be to repair or replace without charge, any defective components if returned promptly. No liability is assumed beyond such replacement. *Consult www.pacific-bearing.com for the latest technical updates.



Simplicity® Ball Bearings

Square Flange Mount - ISO Metric

Linear Motion Systems

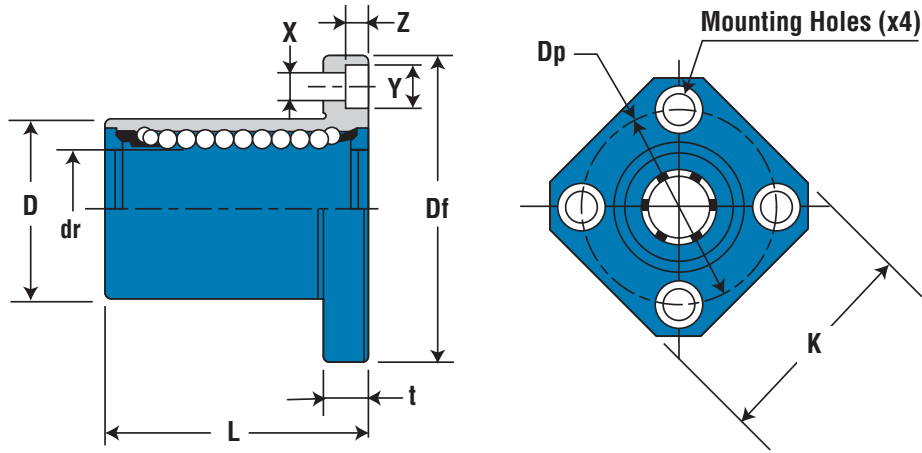

Flange Mount

EPK SERIES - DIMENSIONAL INFORMATION

NOMINAL SHAFT DIAMETER (mm)	PART NUMBER	MAJOR DIMENSIONS & TOLERANCES							
		BALL CIRCUIT	WEIGHT (g)	dr (mm)	TOLERANCE (µm)	D (mm)	TOLERANCE (µm)	L (mm)	TOLERANCE (mm)
8	EPK8G	4	41	8	+8 0	16	0 -13	25	± 0.3
12	EPK12G		80	12		22	0 -16	32	
16	EPK16G	5	103	16	+9 -1	26	0 -19	36	
20	EPK20G		182	20		32		45	
25	EPK25G	6	335	25	+11 -1	40	0 -22	58	
30	EPK30G		560	30		47		68	
40	EPK40G	6	1,175	40	+13 -2	62	0 -25	80	
50	EPK50G		1,745	50		75		100	
60	EPK60G		3,220	60		90		125	

The data and specifications in this publication have been carefully compiled and are believed to be accurate and correct. However, it is the responsibility of the user to determine and ensure the suitability of Pacific Bearing® products for a specific application. Pacific Bearing's only obligation will be to repair or replace without charge, any defective components if returned promptly. No liability is assumed beyond such replacement. *Consult www.pacific-bearing.com for the latest technical updates.



Simplicity® Ball Bearings

Square Flange Mount - ISO Metric

Linear Motion Systems

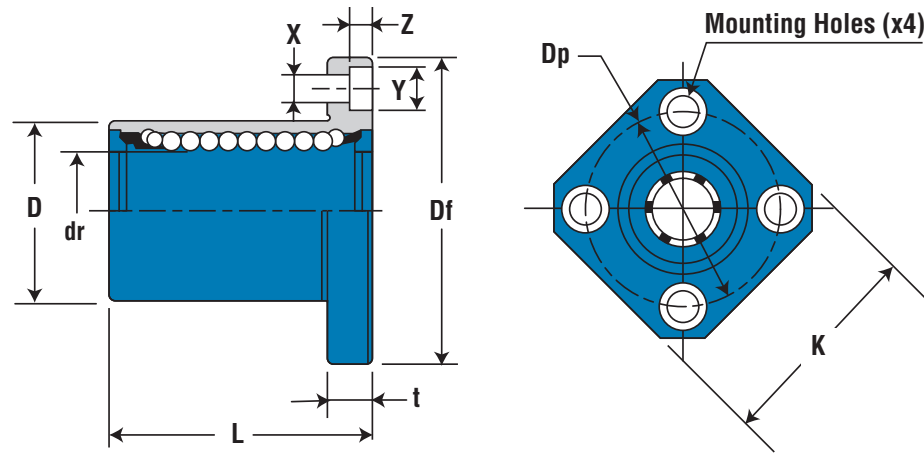

EPK SERIES - DIMENSIONAL INFORMATION (cont.)

(Standard Steel Finish)

MAJOR DIMENSIONS & TOLERANCES						LOAD RATING			
Df (mm)	K (mm)	t (mm)	Dp (mm)	X x Y x Z (mm)	ECCENTRICITY ID to OD (inch/ µm)	PERPENDICULARITY FLANGE FACE to ID (inch/ µm)	DYNAMIC C (N)	STATIC Co (N)	NOMINAL SHAFT DIAMETER (mm)
32	25	5	24	3.5 x 6.0 x 3.1	12	12	265	402	8
42	32	6	32	4.5 x 7.5 x 4.1			510	784	12
46	35		36	4.5 x 7.5 x 4.1			578	892	16
54	42	8	43	5.5 x 9.0 x 5.1	15	15	862	1,370	20
62	50		51	5.5 x 9.0 x 5.1			980	1,570	25
76	60		10	62			6.6 x 11.0 x 6.1	1,570	2,740
98	75	13	80	9.0 x 14.0 x 8.1	17	17	2,160	4,020	40
112	88		94	9.0 x 14.0 x 8.1			3,820	7,940	50
134	106	18	112	11.0 x 17.0 x 11.1	20	20	4,700	9,800	60

Flange Mount

The data and specifications in this publication have been carefully compiled and are believed to be accurate and correct. However, it is the responsibility of the user to determine and ensure the suitability of Pacific Bearing® products for a specific application. Pacific Bearing's only obligation will be to repair or replace without charge, any defective components if returned promptly. No liability is assumed beyond such replacement. *Consult www.pacific-bearing.com for the latest technical updates.



Simplicity® Ball Bearings

Square Flange Mount Double Wide - ISO Metric

Linear Motion Systems

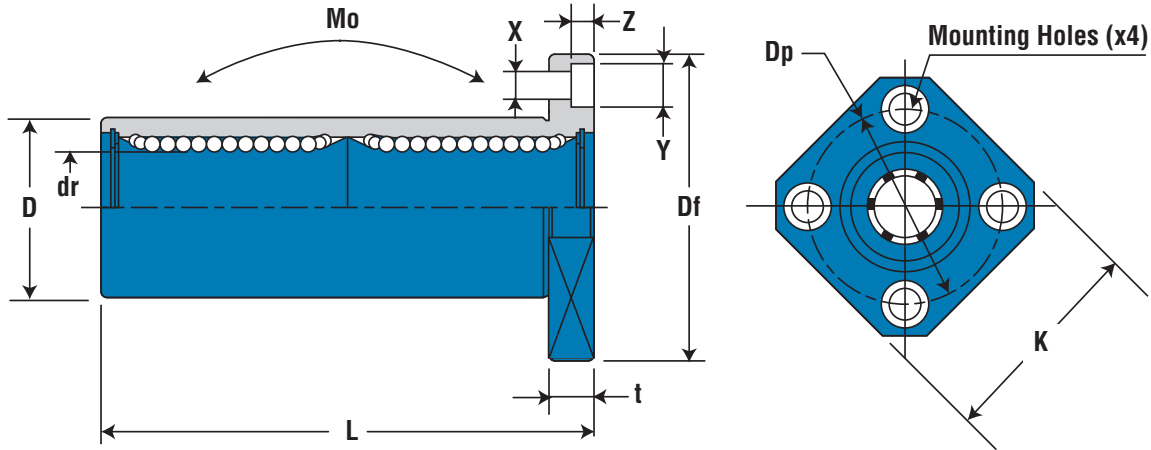

Flange Mount

EPK-W SERIES - DIMENSIONAL INFORMATION

NOMINAL SHAFT DIAMETER (mm)	PART NUMBER	MAJOR DIMENSIONS & TOLERANCES							
		BALL CIRCUIT	WEIGHT (g)	dr (mm)	TOLERANCE (μm)	D (mm)	TOLERANCE (μm)	L (mm)	TOLERANCE (mm)
8	EPK8GW	4	51	8	+9 -1	16	0 -13	46	± 0.3
12	EPK12GW		90	12		22		61	
16	EPK16GW	5	135	16	+11 -1	26	0 -16	68	
20	EPK20GW		225	20		32		80	
25	EPK25GW	6	500	25	+13 -2	40	0 -19	112	
30	EPK30GW		720	30		47		123	
40	EPK40GW	6	1,600	40	+16 -4	62	0 -22	151	
50	EPK50GW		2,620	50		75		192	
60	EPK60GW		4,480	60		90		209	

The data and specifications in this publication have been carefully compiled and are believed to be accurate and correct. However, it is the responsibility of the user to determine and ensure the suitability of Pacific Bearing® products for a specific application. Pacific Bearing's only obligation will be to repair or replace without charge, any defective components if returned promptly. No liability is assumed beyond such replacement. *Consult www.pacific-bearing.com for the latest technical updates.



Simplicity® Ball Bearings

Square Flange Mount Double Wide - ISO Metric

Linear Motion Systems

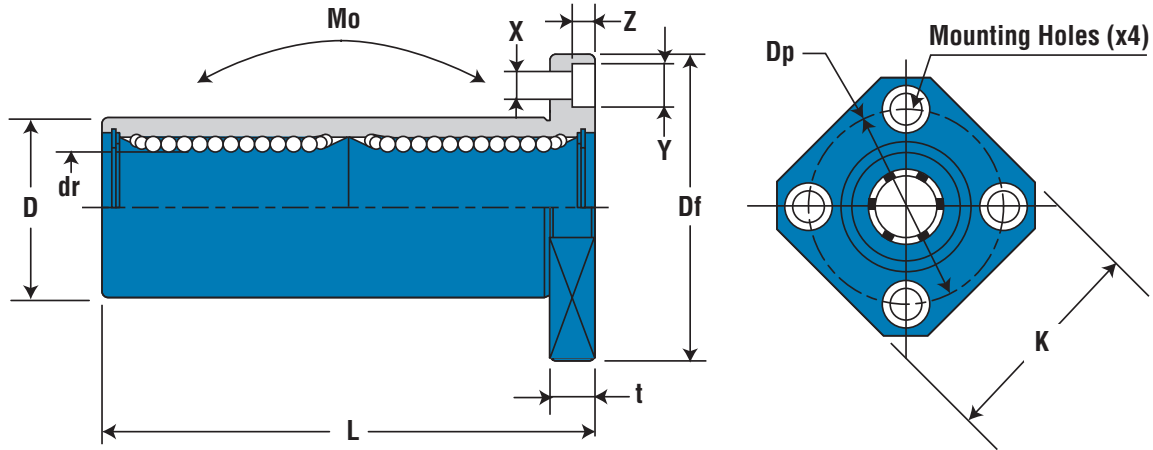

EPK-W SERIES - DIMENSIONAL INFORMATION (cont.)

(Standard Steel Finish)

MAJOR DIMENSIONS & TOLERANCES							LOAD RATING			
Df (mm)	K (mm)	t (mm)	Dp (mm)	X x Y x Z (mm)	ECCENTRICITY ID to OD (inch/ μ m)	PERPENDICULARITY FLANGE FACE to ID (inch/ μ m)	DYNAMIC C (N)	STATIC Co (N)	ALLOWABLE STATIC MOMENT Mo (N-m)	NOMINAL SHAFT DIAMETER (mm)
32	25	5	24	3.5 x 6.0 x 3.1	15	15	421	804	4.3	8
42	32	6	32	4.5 x 7.5 x 4.1			813	1,570	11.7	12
46	35		36	4.5 x 7.5 x 4.1			921	1,780	14.2	16
54	42	8	43	5.5 x 9.0 x 5.1	17	17	1,370	2,740	25	20
62	50		51	5.5 x 9.0 x 5.1			1,570	3,140	44	25
76	60	10	62	6.6 x 11.0 x 6.1			2,500	5,490	78.9	30
98	75	13	80	9.0 x 14.0 x 8.1	20	20	3,430	8,040	147	40
112	88		94	9.0 x 14.0 x 8.1			6,080	15,900	396	50
134	106	18	112	11.0 x 17.0 x 11.1	25	25	7,550	20,000	487	60

Flange Mount

The data and specifications in this publication have been carefully compiled and are believed to be accurate and correct. However, it is the responsibility of the user to determine and ensure the suitability of Pacific Bearing® products for a specific application. Pacific Bearing's only obligation will be to repair or replace without charge, any defective components if returned promptly. No liability is assumed beyond such replacement. *Consult www.pacific-bearing.com for the latest technical updates.

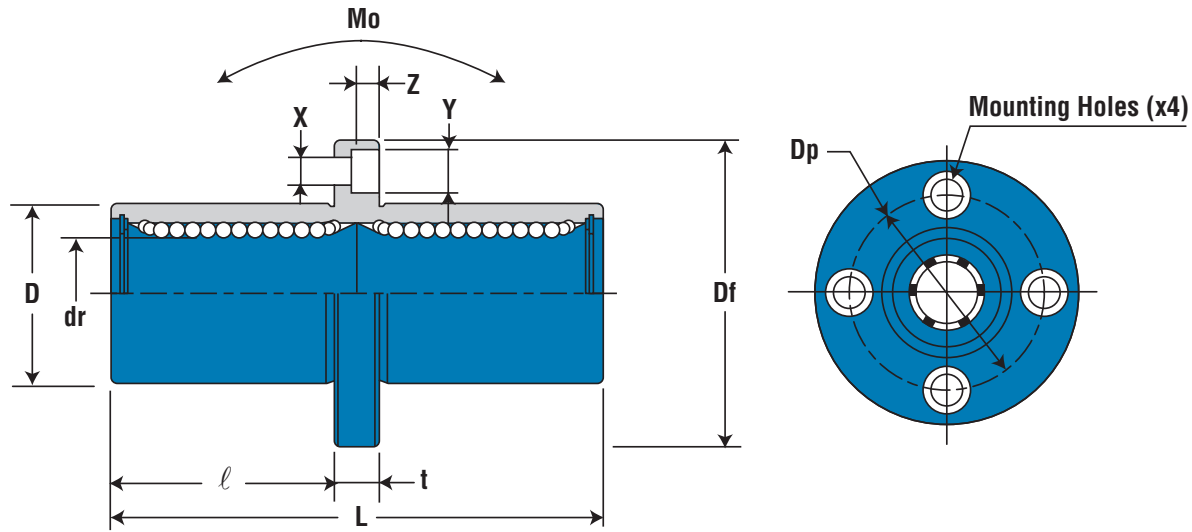

EPFC SERIES - DIMENSIONAL INFORMATION

NOMINAL SHAFT DIAMETER (mm)	PART NUMBER	MAJOR DIMENSIONS & TOLERANCES								
		BALL CIRCUIT	WEIGHT (g)	dr (mm)	TOLERANCE (μm)	D (mm)	TOLERANCE (μm)	L (mm)	TOLERANCE (mm)	l (mm)
8	EPFC8G	4	59	8	+9 -1	16	0 -13	46	± 0.3	20.5
12	EPFC12G		110	12		22		61		27.5
16	EPFC16G	5	160	16	+11 -1	26	0 -16			68
20	EPFC20G		260	20		32		80		36
25	EPFC25G	6	540	25	+13 -2	40	0 -19	112		52
30	EPFC30G		815	30		47		123		56.5
40	EPFC40G	6	1,805	40	+16 -4	62	0 -22	151		69
50	EPFC50G		2,820	50		75		192		89.5
60	EPFC60G		4,920	60		90		209		95.5

The data and specifications in this publication have been carefully compiled and are believed to be accurate and correct. However, it is the responsibility of the user to determine and ensure the suitability of Pacific Bearing® products for a specific application. Pacific Bearing's only obligation will be to repair or replace without charge, any defective components if returned promptly. No liability is assumed beyond such replacement. *Consult www.pacific-bearing.com for the latest technical updates.



Simplicity® Ball Bearings

Round Flange Center Mount - ISO Metric

Linear Motion Systems

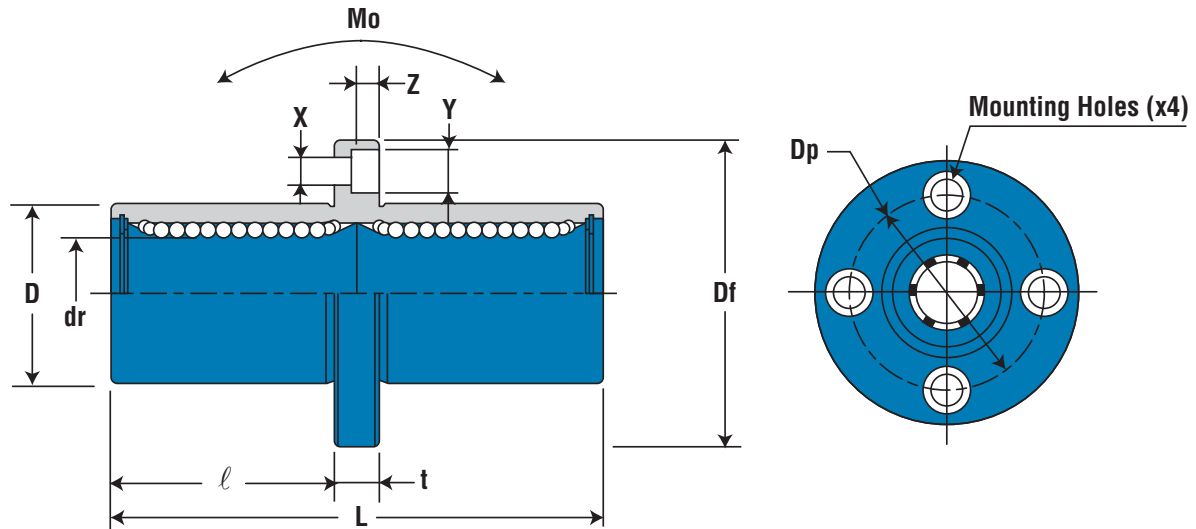

EPFC SERIES - DIMENSIONAL INFORMATION (cont.)

(Standard Steel Finish)

MAJOR DIMENSIONS & TOLERANCES						LOAD RATING			NOMINAL SHAFT DIAMETER (mm)
Df (mm)	t (mm)	Dp (mm)	X x Y x Z (mm)	ECCENTRICITY ID to OD (inch/μm)	PERPENDICULARITY FLANGE FACE to ID (inch/μm)	DYNAMIC C (N)	STATIC Co (N)	ALLOWABLE STATIC MOMENT Mo (N-m)	
32	5	24	3.5 x 6.0 x 3.1	15	15	421	804	4.3	8
42	6	32	4.5 x 7.5 x 4.1			913	1,570	11.7	12
46		36	4.5 x 7.5 x 4.1			921	1,780	14.2	16
54	8	43	5.5 x 9.0 x 5.1	17	17	1,370	2,740	25	20
62		51	5.5 x 9.0 x 5.1			1,570	3,140	44	25
76		10	62			6.6 x 11.0 x 6.1	2,500	5,490	78.9
98	13	80	9.0 x 14.0 x 8.1	20	20	3,430	8,040	147	40
112		94	9.0 x 14.0 x 8.1			6,080	15,900	396	50
134	18	112	11.0 x 17.0 x 11.1	25	25	7,550	20,000	487	60

Flange Mount

The data and specifications in this publication have been carefully compiled and are believed to be accurate and correct. However, it is the responsibility of the user to determine and ensure the suitability of Pacific Bearing® products for a specific application. Pacific Bearing's only obligation will be to repair or replace without charge, any defective components if returned promptly. No liability is assumed beyond such replacement. *Consult www.pacific-bearing.com for the latest technical updates.

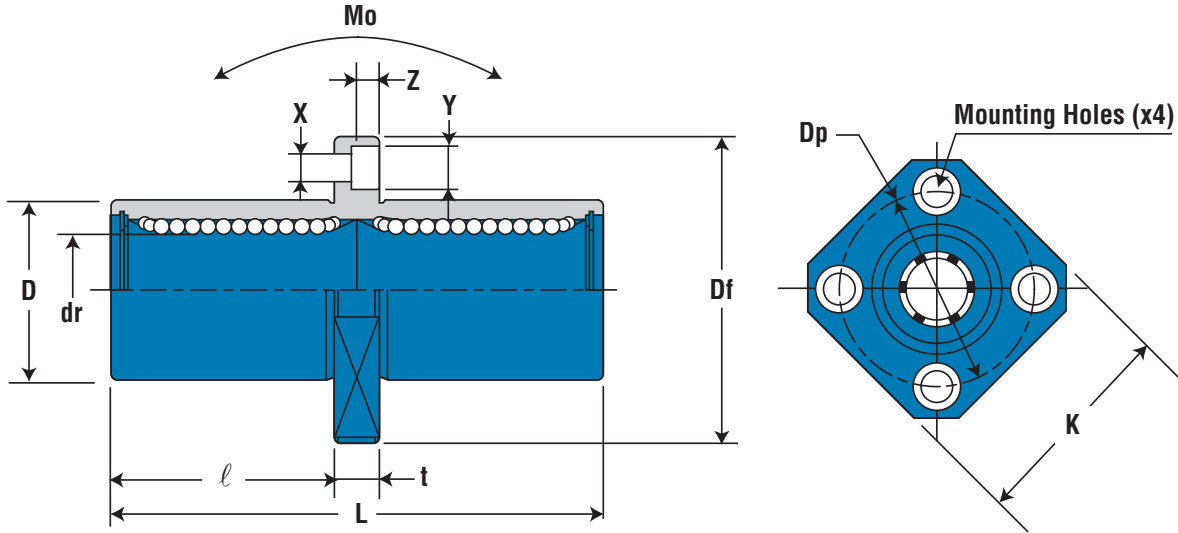

Flange Mount

EPKC SERIES - DIMENSIONAL INFORMATION

PART NUMBER		MAJOR DIMENSIONS & TOLERANCES							
NOMINAL SHAFT DIAMETER (mm)	STANDARD POLYMER CAGE	BALL CIRCUIT	WEIGHT (g)	dr (mm)	TOLERANCE (µm)	D (mm)	TOLERANCE (µm)	L (mm)	TOLERANCE (mm)
8	EPKC8G	4	51	8	+9 -1	16	0 -13	46	± 0.3
12	EPKC12G		90	12		22		61	
16	EPKC16G	5	135	16	+11 -1	26	0 -16	68	
20	EPKC20G		225	20		32		80	
25	EPKC25G	6	500	25	+13 -2	40	0 -19	112	
30	EPKC30G		720	30		47		123	
40	EPKC40G	6	1,600	40	+16 -4	62	0 -22	151	
50	EPKC50G		2,620	50		75		192	
60	EPKC60G		4,480	60		90		209	

The data and specifications in this publication have been carefully compiled and are believed to be accurate and correct. However, it is the responsibility of the user to determine and ensure the suitability of Pacific Bearing® products for a specific application. Pacific Bearing's only obligation will be to repair or replace without charge, any defective components if returned promptly. No liability is assumed beyond such replacement. *Consult www.pacific-bearing.com for the latest technical updates.



Simplicity® Ball Bearings

Square Flange Center Mount - ISO Metric

Linear Motion Systems

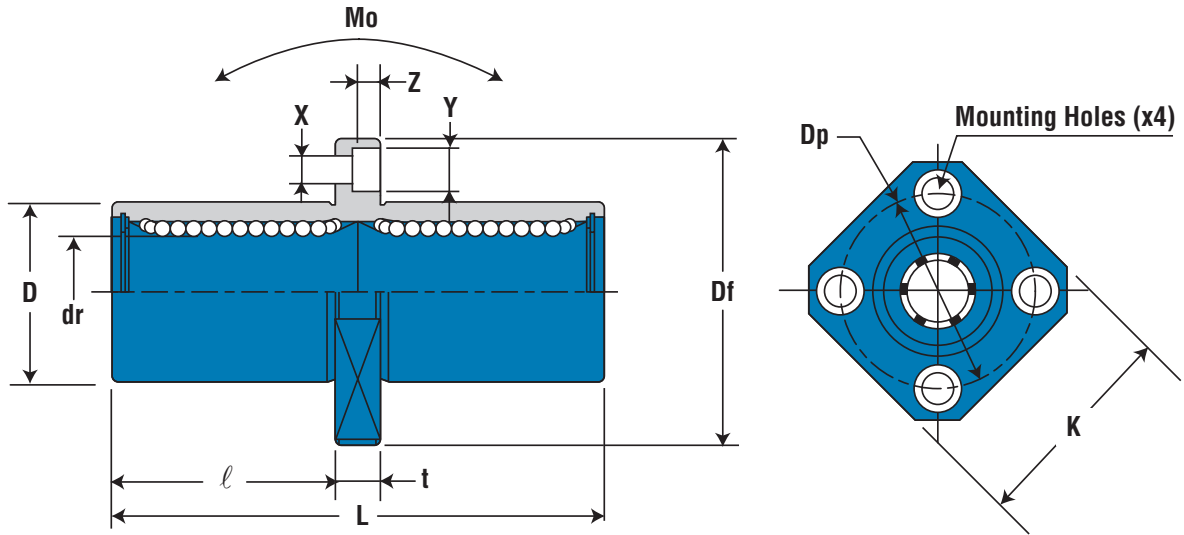

EPKC SERIES - DIMENSIONAL INFORMATION (cont.)

(Standard Steel Finish)

MAJOR DIMENSIONS & TOLERANCES								LOAD RATING			
l (mm)	D_f (mm)	K (mm)	t (mm)	D_p (mm)	$X \times Y \times Z$ (mm)	ECCENTRICITY ID to OD (inch/ μ m)	PERPENDICULARITY FLANGE FACE to ID (inch/ μ m)	DYNAMIC C (N)	STATIC C_o (N)	ALLOWABLE STATIC MOMENT M_o (N-m)	NOMINAL SHAFT DIAMETER (mm)
20.5	32	25	5	24	3.5 x 6.0 x 3.1	15	15	421	804	4.3	8
27.5	42	32	6	32	4.5 x 7.5 x 4.1			913	1,570	11.7	12
31	46	35		36	4.5 x 7.5 x 4.1			921	1,780	14.2	16
36	54	42	8	43	5.5 x 9.0 x 5.1	17	17	1,370	2,740	25	20
52	62	50		51	5.5 x 9.0 x 5.1			1,570	3,140	44	25
56.5	76	60		10	62			6.6 x 11.0 x 6.1	2,500	5,490	78.9
69	98	75	13	80	9.0 x 14.0 x 8.1	20	20	3,430	8,040	147	40
89.5	112	88		94	9.0 x 14.0 x 8.1			6,080	15,900	396	50
95.5	134	106	18	112	11.0 x 17.0 x 11.1	25	25	7,550	20,000	487	60

The data and specifications in this publication have been carefully compiled and are believed to be accurate and correct. However, it is the responsibility of the user to determine and ensure the suitability of Pacific Bearing® products for a specific application. Pacific Bearing's only obligation will be to repair or replace without charge, any defective components if returned promptly. No liability is assumed beyond such replacement. *Consult www.pacific-bearing.com for the latest technical updates.



Simplicity® Ball Bearings

Closed & Open Pillow Blocks - ISO & JIS Metric

Linear Motion Systems

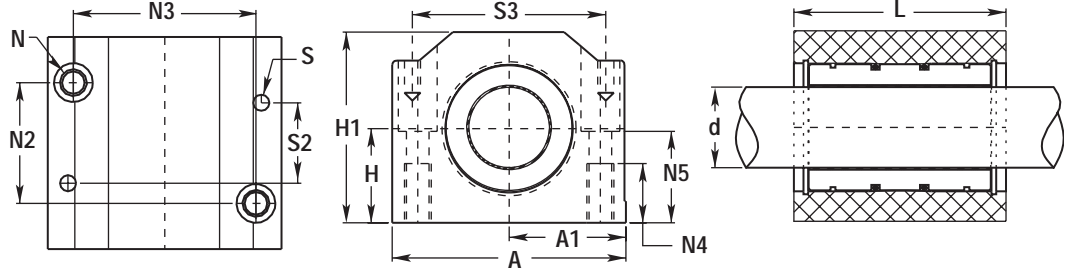

CLOSED PILLOW BLOCKS

PART NO.	d NOM. I.D.	H	H1	A	A1	L	N								ASSEM. WT.
	MIN.	CENTERLINE .015	HEIGHT	WIDTH	.013	LENGTH	BOLT	N2	N3	N4	N5	S	S2	S3	(kg.)
EPPM08G	8	15	28	35	17.5	32	M4 x 0.7	20.15	25.15	9	14.5	N / A	N / A	N / A	0.069
EPPM10G	10	16	31.5	40	20	36	M5 x 0.8								
EPPM12G	12	18	35	43	21.5	39	M5 x 0.8	23.15	3.15	13	21	5	45	50	0.329
EPPM16G	16	22	42	53	26.5	43	M6 x 1.0	26.15	40.15						
EPPM20G	20	25	50	60	30	54	M8 x 1.25	32.15	45.15	34	34	30	72	1.020	
EPPM25G	25	30	60	78	39	67	M10 x 1.5	40.15	60.15						26
EPPM30G	30	35	71	87	43.5	79	M10 x 1.5	45.15	68.15	34	44	8	35	90	
EPPM40G	40	45	91	108	54	91	M12 x 1.75	58.15	86.15						34
EPPM50G	50	50	105	132	66	113	M16 x 2.0	50.20	108.2	34	49	10	42	108	

- NOTES: (1) Standard pillow block assembly includes self-aligning housing and precision bearing.
 (2) All standard metric pillow blocks use standard "EP" series bearings found on page 88-89.
 (3) Straight bore pillow block assembly includes standard O.D. "EP" series bearing in straight bore housing.

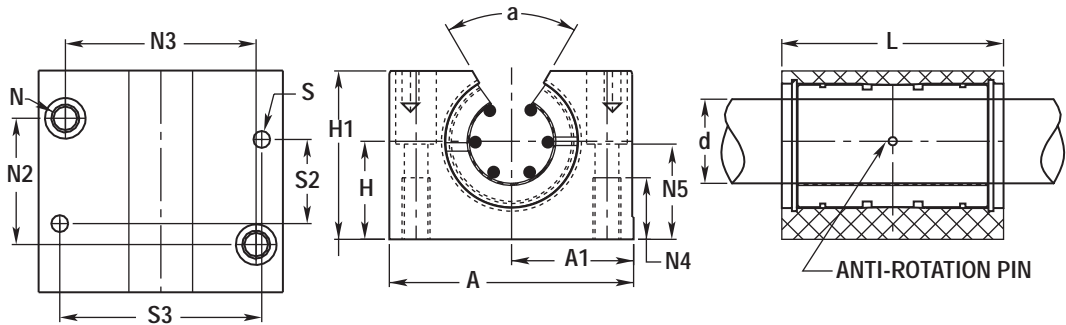

OPEN PILLOW BLOCKS

PART NO.	d NOM. I.D.	H	H1	A	A1	L	N								ASSEM. WT.	
	MIN.	CENTERLINE .015	HEIGHT	WIDTH	CENTERLINE .013	LENGTH	BOLT	N2	N3	N4	N5	S	S2	S3	a	(kg.)
EPPMN12G	12	18	28	43	21.5	39	M5 x 0.8	23.15	32.15	11	16.5	4	32	34	66	0.096
EPPMN16G	16	22	35	53	26.5	43	M6 x 1.0	26.15	40.15	13	21					
EPPMN20G	20	25	42	60	30	54	M8 x 1.25	32.15	45.15	18	24	5	45	50	60	0.267
EPPMN25G	25	30	51	78	39	67	M10 x 1.5	40.15	60.15	22	29					
EPPMN30G	30	35	60	87	43.5	79	M10 x 1.5	45.15	68.15			34	34	30	72	60
EPPMN40G	40	45	77	108	54	91	M12 x 1.75	58.15	86.15	26	44					
EPPMN50G	50	50	88	132	66	113	M16 x 2.0	50.20	108.2			34	49	10	42	108

- NOTES: (1) Standard pillow block assembly includes self-aligning housing and precision bearing.
 (2) All standard metric pillow blocks use standard "EP" series bearings found on page 88-89.

(For Empty Pillow Block with no bearings included add LBB after the part number.)

The data and specifications in this publication have been carefully compiled and are believed to be accurate and correct. However, it is the responsibility of the user to determine and ensure the suitability of Pacific Bearing® products for a specific application. Pacific Bearing's only obligation will be to repair or replace without charge, any defective components if returned promptly. No liability is assumed beyond such replacement. *Consult www.pacific-bearing.com for the latest technical updates.



Simplicity® Ball Bearings

Compact Thin Wall Bearings - ISO Metric

Linear Motion Systems

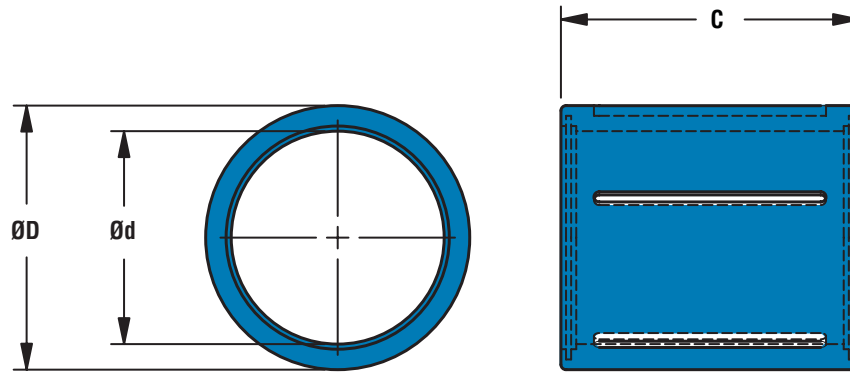

BASIC DIMENSIONAL INFORMATION

(Standard Steel Finish)

PART NO.	DIMENSIONS				LOAD RATING	
	Ød	ØD	B	WEIGHT (g)	DYNAMIC C (N)	STATIC Co (N)
KHP6	6	12	22	7.0	400	239
KHP8	8	15	24	12.0	435	280
KHP10	10	17	26	14.5	500	370
KHP12	12	19	28	18.5	620	510
KHP14	14	21		20.5		520
KHP16	16	24	30	27.5	800	620
KHP20	20	28		32.5	950	790
KHP25	25	35	40	66.0	1,990	1,670
KHP30	30	40	50	95.0	2,880	2,700
KHP40	40	52	60	182.0	4,400	4,450
KHP50	50	62	70	252.0	5,500	6,300

Compact Thin Wall

The data and specifications in this publication have been carefully compiled and are believed to be accurate and correct. However, it is the responsibility of the user to determine and ensure the suitability of Pacific Bearing® products for a specific application. Pacific Bearing's only obligation will be to repair or replace without charge, any defective components if returned promptly. No liability is assumed beyond such replacement. *Consult www.pacific-bearing.com for the latest technical updates.



Simplicity® Ball Bearings

Linear Ball Bearings - JIS Metric

Linear Motion Systems

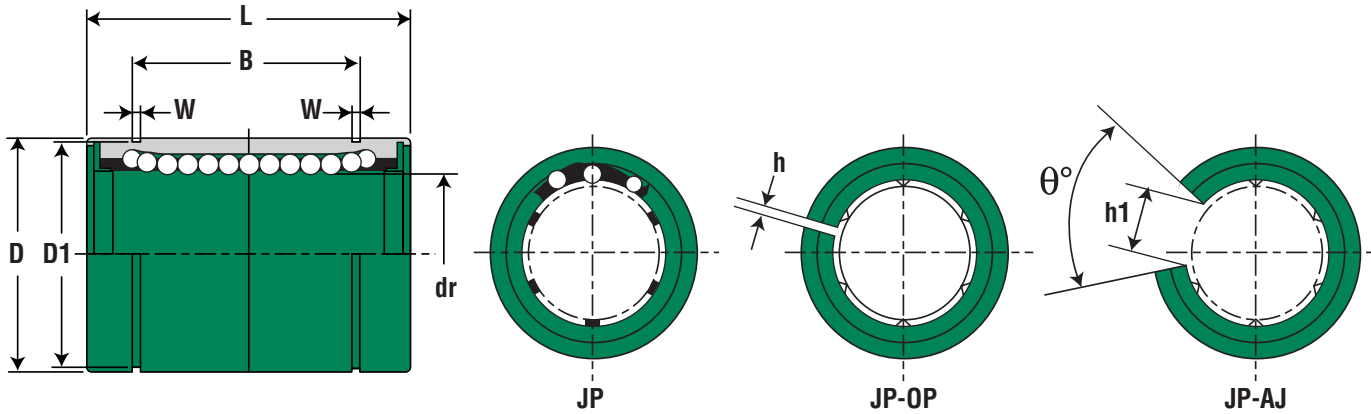

JP SERIES - DIMENSIONAL INFORMATION

NOMINAL SHAFT DIAMETER (mm)	PART NUMBER					MAJOR DIMENSIONS & TOLERANCES						
	STANDARD CLOSE POLYMER CAGE	BALL CIRCUIT	WEIGHT (g)	STANDARD OPEN POLYMER CAGE	ADJUSTABLE POLYMER CAGE	dr (mm)	TOLERANCE (µm)	D (mm)	TOLERANCE (µm)	L (mm)	TOLERANCE (mm)	
8	JP8G	4	16	-	-	8	0 -9	15	0 -11	24	0 -0.2	
10	JP10G		30	-	-	10		19		29		
12	JP12G		32	JP12G-OP	JP12G-AJ	12		21	0 -13	30		
13	JP13G		43	JP13G-OP	JP13G-AJ	13		23		32		
16	JP16G	5	69	JP16G-OP	JP16G-AJ	16		28		37		
20	JP20G		87	JP20G-OP	JP20G-AJ	20		32				42
25	JP25G	6	220	JP25G-OP	JP25G-AJ	25	0 -10	40	0 -16	59	0 -0.3	
30	JP30G		250	JP30G-OP	JP30G-AJ	30	0 -12	45	0 -19	64		
35	JP35G		390	JP35G-OP	JP35G-AJ	35		52				70
40	JP40G		585	JP40G-OP	JP40G-AJ	40		60				80
50	JP50G		1,580	JP50G-OP	JP50G-AJ	50		80				100
60	JP60G		2,000	JP60G-OP	JP60G-AJ	60		0 -15		90		0 -22

The data and specifications in this publication have been carefully compiled and are believed to be accurate and correct. However, it is the responsibility of the user to determine and ensure the suitability of Pacific Bearing® products for a specific application. Pacific Bearing's only obligation will be to repair or replace without charge, any defective components if returned promptly. No liability is assumed beyond such replacement. *Consult www.pacific-bearing.com for the latest technical updates.

Ball Bearings

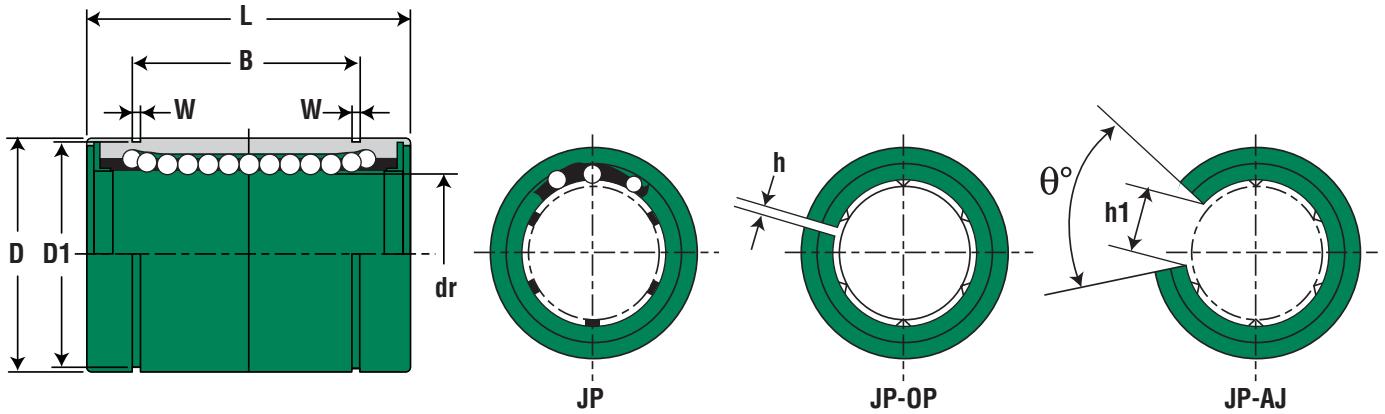

JP SERIES - DIMENSIONAL INFORMATION (cont.)

(Standard Steel Finish)

MAJOR DIMENSIONS & TOLERANCES											LOAD RATING				
B (mm)	TOLERANCE (mm)	W (mm)	TOLERANCE (mm)	D1 (mm)	TOLERANCE (mm)	h (mm)	h1 (mm)	l (°)	ECCENTRICITY (µm)	MAX RADIAL CLEARANCE (µm)	DYNAMIC C (N)	STATIC Co (N)	NOMINAL SHAFT DIAMETER (mm)		
17.5	0 -0.2	1.1	+.14 0	14.3	0 -0.11	-	-	-	12	-3	260	400	8		
22		1.3		18		-	-	-							
23		1.3		20	1.5	8	80	-4			410	590	12		
23		1.3		22		9									
26.5		1.6		27		11									
30.5		0 -0.3		1.6	+.14 0	30.5	0 -0.21	11	60	50	20	-6	860	1,370	20
41	1.85		38	2		12		15	980						
44.5	1.85		43	2.5		15	-8						1,660	3,130	35
49.5	2.1		49			17									
60.5	2.1		57	3		20		20	-10	2,150	4,010	40			
74	2.6		76.5			25									
85	3.15	86.5	30		25	-13	3,820						7,930	50	

The data and specifications in this publication have been carefully compiled and are believed to be accurate and correct. However, it is the responsibility of the user to determine and ensure the suitability of Pacific Bearing® products for a specific application. Pacific Bearing's only obligation will be to repair or replace without charge, any defective components if returned promptly. No liability is assumed beyond such replacement. *Consult www.pacific-bearing.com for the latest technical updates.



Simplicity® Ball Bearings

Double Wide Linear Ball Bearings - JIS Metric

Linear Motion Systems

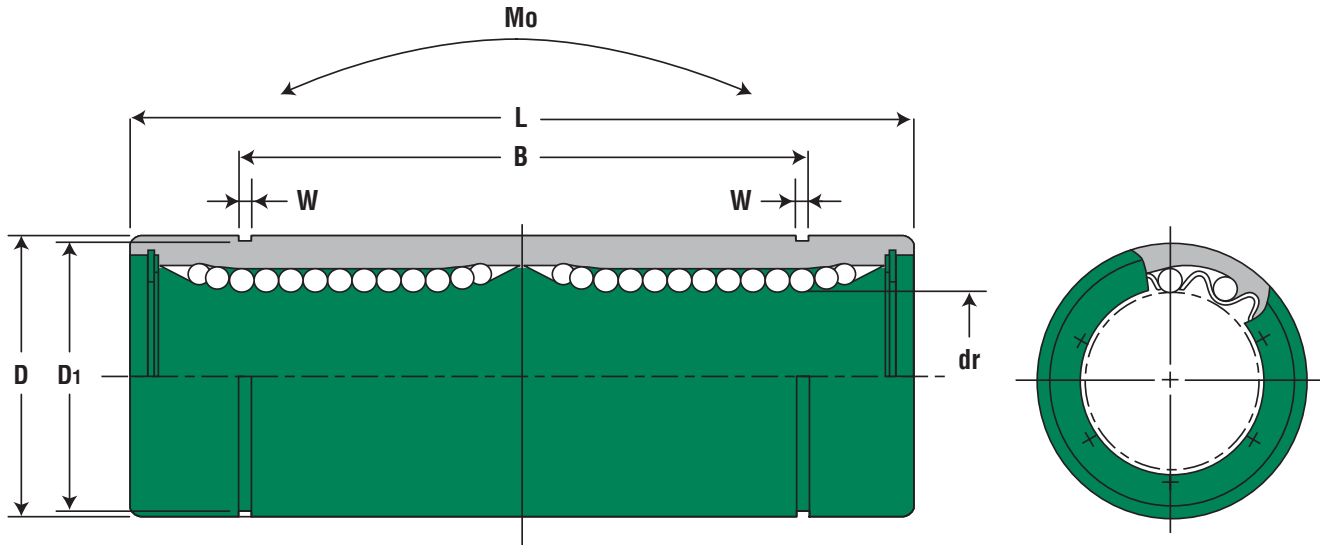

JP-W SERIES - DIMENSIONAL INFORMATION

NOMINAL SHAFT DIAMETER (mm)	PART NUMBER	MAJOR DIMENSIONS & TOLERANCES							
		BALL CIRCUIT	WEIGHT (g)	dr (mm)	TOLERANCE (µm)	D (mm)	TOLERANCE (µm)	L (mm)	TOLERANCE (mm)
8	JP8GW	4	31	8	0 -10	15	0 -13	45	0 -0.3
12	JP12GW		80	12		21	0 -16	57	
16	JP16GW	5	145	16		28	0 -19	70	
20	JP20GW		180	20	32	0 -22	80		
25	JP25GW	6	440	25	0 -12	40	0 -19	112	0 -0.4
30	JP30GW		580	30		45	0 -22	123	
40	JP40GW		1,170	40	0 -15	60	0 -22	151	
50	JP50GW		3,100	50		80	0 -25	192	
60	JP60GW		3,500	60	0 -20	90	0 -25	209	

The data and specifications in this publication have been carefully compiled and are believed to be accurate and correct. However, it is the responsibility of the user to determine and ensure the suitability of Pacific Bearing® products for a specific application. Pacific Bearing's only obligation will be to repair or replace without charge, any defective components if returned promptly. No liability is assumed beyond such replacement. *Consult www.pacific-bearing.com for the latest technical updates.



Simplicity® Ball Bearings

Double Wide Linear Ball Bearings - JIS Metric

Linear Motion Systems

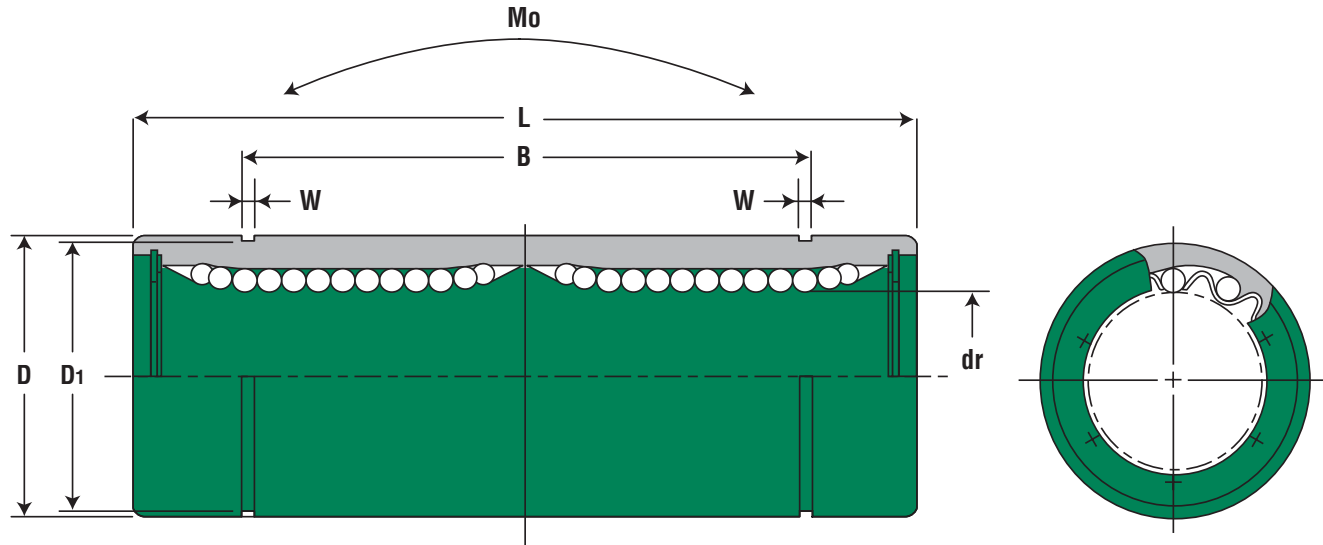

JP-W SERIES - DIMENSIONAL INFORMATION (cont.)

(Standard Steel Finish)

MAJOR DIMENSIONS & TOLERANCES							LOAD RATING			
B (mm)	TOLERANCE (mm)	W (mm)	TOLERANCE (mm)	D1 (mm)	TOLERANCE (mm)	ECCENTRICITY (µm)	DYNAMIC C (N)	STATIC Co (N)	ALLOWABLE STATIC MOMENT Mo (N-m)	NOMINAL SHAFT DIAMETER (mm)
35	0 -0.3	1.1	+0.14 0	14.3	0 -0.11	15	431	784	4.3	8
46		1.3		20	0 -0.13		657	1,200	10.9	12
53		1.6		27	0 -0.21		1,230	2,350	19.7	16
61	0 -0.4	1.6	+0.14 0	30.5	0 -0.25	20	1,400	2,750	26.8	20
82		1.85		38			1,560	3,140	43.4	25
89		1.85		43			2,490	5,490	82.8	30
121		2.1		57			3,430	8,040	147	40
148		2.6		76.5			6,080	15,900	397	50
170	3.15	86.5	0 -0.35	30	7,650	20,000	530	60		

Ball Bearings

The data and specifications in this publication have been carefully compiled and are believed to be accurate and correct. However, it is the responsibility of the user to determine and ensure the suitability of Pacific Bearing® products for a specific application. Pacific Bearing's only obligation will be to repair or replace without charge, any defective components if returned promptly. No liability is assumed beyond such replacement. *Consult www.pacific-bearing.com for the latest technical updates.



Simplicity® Ball Bearings

Round Flange Mount - JIS Metric

Linear Motion Systems

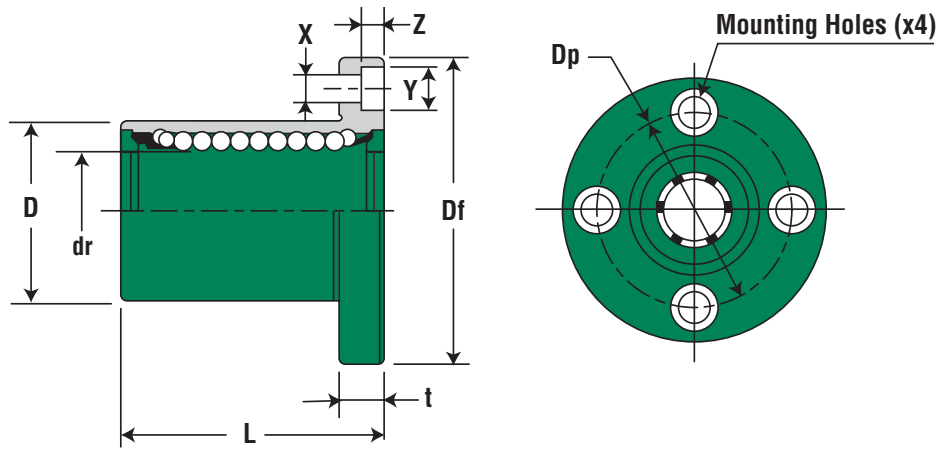

JPF SERIES - DIMENSIONAL INFORMATION

NOMINAL SHAFT DIAMETER (mm)	PART NUMBER	MAJOR DIMENSIONS & TOLERANCES							
		BALL CIRCUIT	WEIGHT (g)	dr (mm)	TOLERANCE (µm)	D (mm)	TOLERANCE (µm)	L (mm)	TOLERANCE (mm)
8	JPF8G	4	37	8	0 -9	15	0 -13	24	± 0.3
12	JPF12G		76	12		21	0 -16	30	
16	JPF16G	5	120	16		28		37	
20	JPF20G		180	20	32	0 -19	42		
25	JPF25G	6	340	25	40		59		
30	JPF30G		470	30	45	64			
40	JPF40G	1,060	40	60	0 -22	80			
50	JPF50G	2,200	50	80		100			
60	JPF60G	3,000	60	90	0 -25	110			

Flange Mount

The data and specifications in this publication have been carefully compiled and are believed to be accurate and correct. However, it is the responsibility of the user to determine and ensure the suitability of Pacific Bearing® products for a specific application. Pacific Bearing's only obligation will be to repair or replace without charge, any defective components if returned promptly. No liability is assumed beyond such replacement. *Consult www.pacific-bearing.com for the latest technical updates.



Simplicity® Ball Bearings

Round Flange Mount - JIS Metric

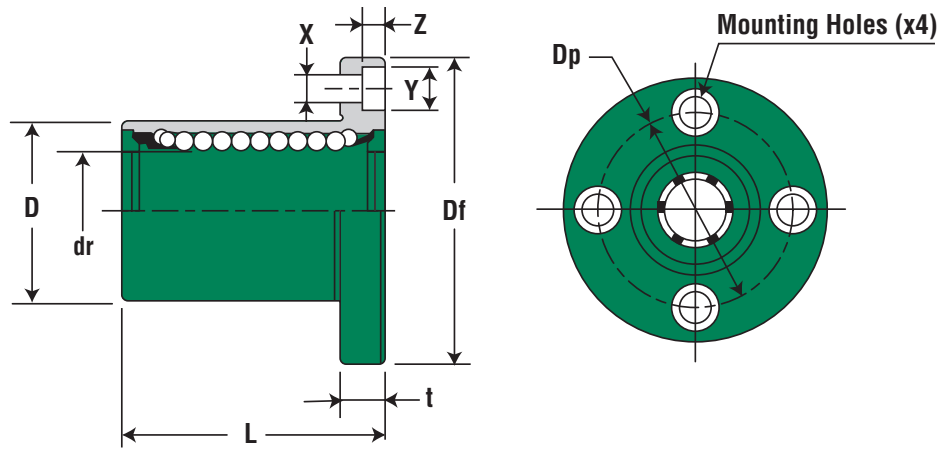

JPF SERIES - DIMENSIONAL INFORMATION (cont.)

(Standard Steel Finish)

MAJOR DIMENSIONS & TOLERANCES						LOAD RATING		
Df (mm)	t (mm)	Dp (mm)	X x Y x Z (mm)	ECCENTRICITY ID to OD (inch/ μ m)	PERPENDICULARITY FLANGE FACE to ID (inch/ μ m)	DYNAMIC C (N)	STATIC Co (N)	NOMINAL SHAFT DIAMETER (mm)
32	5	24	3.5 x 6 x 3.1	12	12	274	392	8
42	6	32	4.5 x 7.5 x 4.1			510	784	12
48		38				774	1,180	16
54	8	43	5.5 x 9 x 5.1	15	15	882	1,370	20
62		51				980	1,570	25
74		60				1,570	2,740	30
96	13	78	9 x 14 x 8.1	20	20	2,160	4,020	40
116		98				3,820	7,940	50
134	18	112	11 x 17 x 11.1	25	25	4,700	10,000	60

Flange Mount

The data and specifications in this publication have been carefully compiled and are believed to be accurate and correct. However, it is the responsibility of the user to determine and ensure the suitability of Pacific Bearing® products for a specific application. Pacific Bearing's only obligation will be to repair or replace without charge, any defective components if returned promptly. No liability is assumed beyond such replacement. *Consult www.pacific-bearing.com for the latest technical updates.



Simplicity® Ball Bearings

Round Flange Mount Double Wide - JIS Metric

Linear Motion Systems

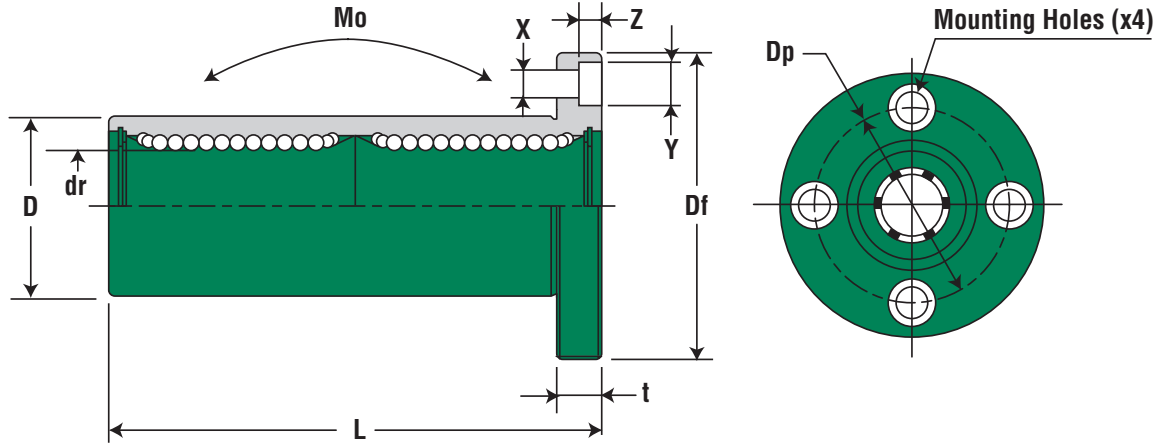

JPF-W SERIES - DIMENSIONAL INFORMATION

NOMINAL SHAFT DIAMETER (mm)	PART NUMBER	MAJOR DIMENSIONS & TOLERANCES							
		BALL CIRCUIT	WEIGHT (g)	dr (mm)	TOLERANCE (μm)	D (mm)	TOLERANCE (μm)	L (mm)	TOLERANCE (mm)
8	JPF8GW	4	51	8	0 -10	15	0 -13	45	± 0.3
12	JPF12GW		110	12		21	0 -16	57	
16	JPF16GW	5	190	16		28		70	
20	JPF20GW		260	20	32	0 -19	80		
25	JPF25GW	6	540	25	40		112		
30	JPF30GW		680	30	45	123			
40	JPF40GW	1,570	40	0 -15	60	0 -22	151		
50	JPF50GW	3,600	50		80	192			
60	JPF60GW	4,500	60	0 -20	90	0 -25	209		

Flange Mount

The data and specifications in this publication have been carefully compiled and are believed to be accurate and correct. However, it is the responsibility of the user to determine and ensure the suitability of Pacific Bearing® products for a specific application. Pacific Bearing's only obligation will be to repair or replace without charge, any defective components if returned promptly. No liability is assumed beyond such replacement. *Consult www.pacific-bearing.com for the latest technical updates.



Simplicity® Ball Bearings

Round Flange Mount Double Wide - JIS Metric

Linear Motion Systems

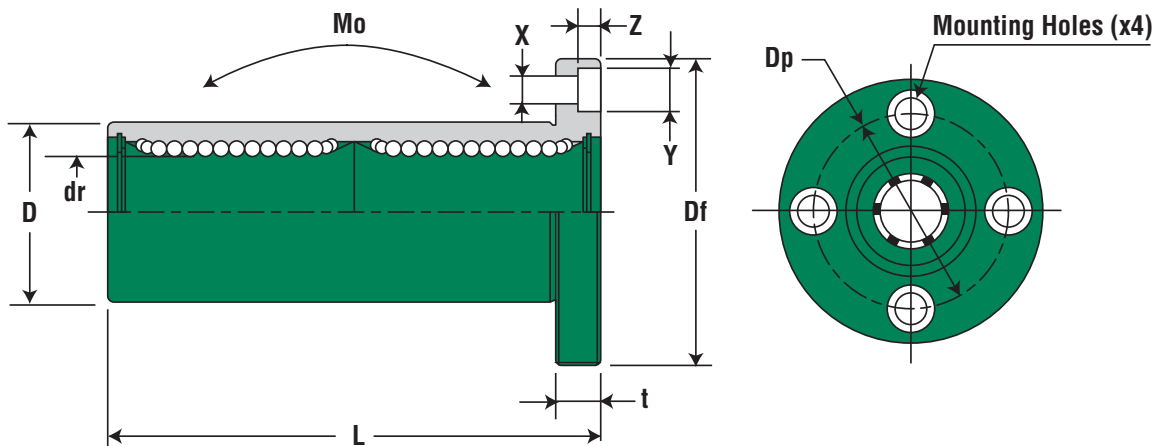

JPF-W SERIES - DIMENSIONAL INFORMATION (cont.)

(Standard Steel Finish)

MAJOR DIMENSIONS & TOLERANCES						LOAD RATING			
Df (mm)	t (mm)	Dp (mm)	X x Y x Z (mm)	ECCENTRICITY ID to OD (inch/μm)	PERPENDICULARITY FLANGE FACE to ID (inch/μm)	DYNAMIC C (N)	STATIC Co (N)	ALLOWABLE STATIC MOMENT Mo (N-m)	NOMINAL SHAFT DIAMETER (mm)
32	5	24	3.5 x 6 x 3.1	15	15	431	784	4.3	8
42	6	32	4.5 x 7.5 x 4.1			813	1,570	10.9	12
48	6	38				1,230	2,350	19.7	16
54	8	43	5.5 x 9 x 5.1	20	20	1,400	2,740	26.8	20
62	8	51				1,560	3,140	43.4	25
74	10	60	6.6 x 11 x 6.1			2,490	5,490	82.8	30
96	13	78	9 x 14 x 8.1	25	25	3,430	8,040	147	40
116	13	98				6,080	15,900	397	50
134	18	112	11 x 17 x 11.1			30	30	7,550	20,000

Flange Mount

The data and specifications in this publication have been carefully compiled and are believed to be accurate and correct. However, it is the responsibility of the user to determine and ensure the suitability of Pacific Bearing® products for a specific application. Pacific Bearing's only obligation will be to repair or replace without charge, any defective components if returned promptly. No liability is assumed beyond such replacement. *Consult www.pacific-bearing.com for the latest technical updates.



Simplicity® Ball Bearings

Square Flange Mount - JIS Metric

Linear Motion Systems

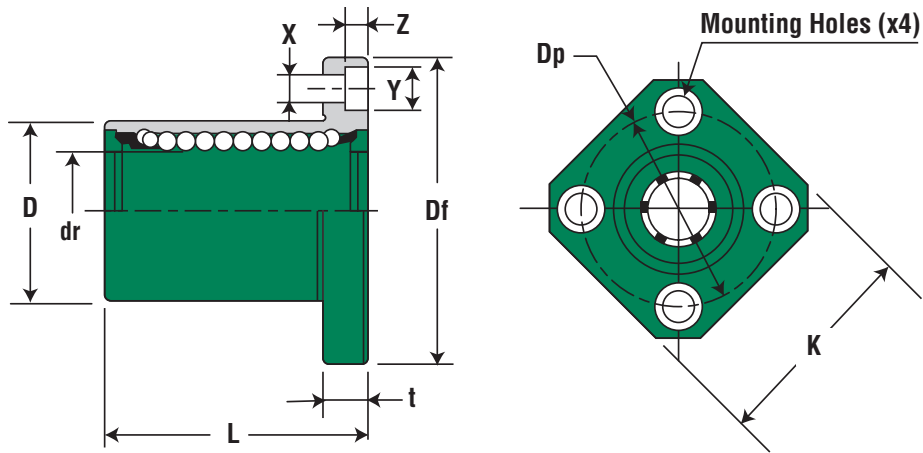

JPK SERIES - DIMENSIONAL INFORMATION

NOMINAL SHAFT DIAMETER (mm)	PART NUMBER	MAJOR DIMENSIONS & TOLERANCES							
		BALL CIRCUIT	WEIGHT (g)	dr (mm)	TOLERANCE (μm)	D (mm)	TOLERANCE (μm)	L (mm)	TOLERANCE (mm)
8	JPK8G	4	37	8	0 -9	15	0 -13	24	± 0.3
12	JPK12G		76	12		21	0 -16	30	
16	JPK16G	5	120	16		28		37	
20	JPK20G		180	20	32	0 -19	42		
25	JPK25G	6	340	25	40		59		
30	JPK30G		470	30	45		64		
40	JPK40G	6	1,060	40	0 -12	60	0 -22	80	
50	JPK50G		2,200	50		80	100		
60	JPK60G		3,000	60	0 -15	90	0 -25	110	

Flange Mount

The data and specifications in this publication have been carefully compiled and are believed to be accurate and correct. However, it is the responsibility of the user to determine and ensure the suitability of Pacific Bearing® products for a specific application. Pacific Bearing's only obligation will be to repair or replace without charge, any defective components if returned promptly. No liability is assumed beyond such replacement. *Consult www.pacific-bearing.com for the latest technical updates.



Simplicity® Ball Bearings

Square Flange Mount - JIS Metric

Linear Motion Systems

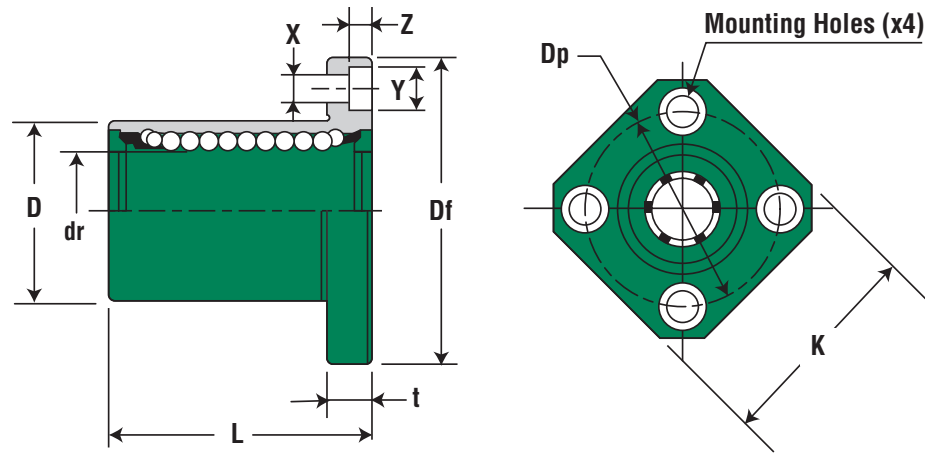

JPK SERIES - DIMENSIONAL INFORMATION (cont.)

(Standard Steel Finish)

MAJOR DIMENSIONS & TOLERANCE							LOAD RATING		
Df (mm)	K (mm)	t (mm)	Dp (mm)	X x Y x Z (mm)	ECCENTRICITY ID to OD (Inch/μm)	PERPENDICULARITY FLANGE FACE to ID (Inch/μm)	DYNAMIC C (N)	STATIC Co (N)	NOMINAL SHAFT DIAMETER (mm)
32	25	5	24	3.5 x 6 x 3.1	12	12	274	392	8
42	32	6	4.5 x 7.5 x 4.1	510			784	12	
48	37			38			774	1,180	16
54	42	8	43	5.5 x 9 x 5.1	15	15	882	1,370	20
62	50						51	980	1,570
74	58	10	60	6.6 x 11 x 6.1			1,570	2,740	30
96	75	13	78	9 x 14 x 8.1	20	20	2,160	4,020	40
116	92						98	3,820	7,940
134	106	18	112	11 x 17 x 11.1			25	25	4,700

Flange Mount

The data and specifications in this publication have been carefully compiled and are believed to be accurate and correct. However, it is the responsibility of the user to determine and ensure the suitability of Pacific Bearing® products for a specific application. Pacific Bearing's only obligation will be to repair or replace without charge, any defective components if returned promptly. No liability is assumed beyond such replacement. *Consult www.pacific-bearing.com for the latest technical updates.



Simplicity® Ball Bearings

Square Flange Mount Double Wide - JIS Metric

Linear Motion Systems

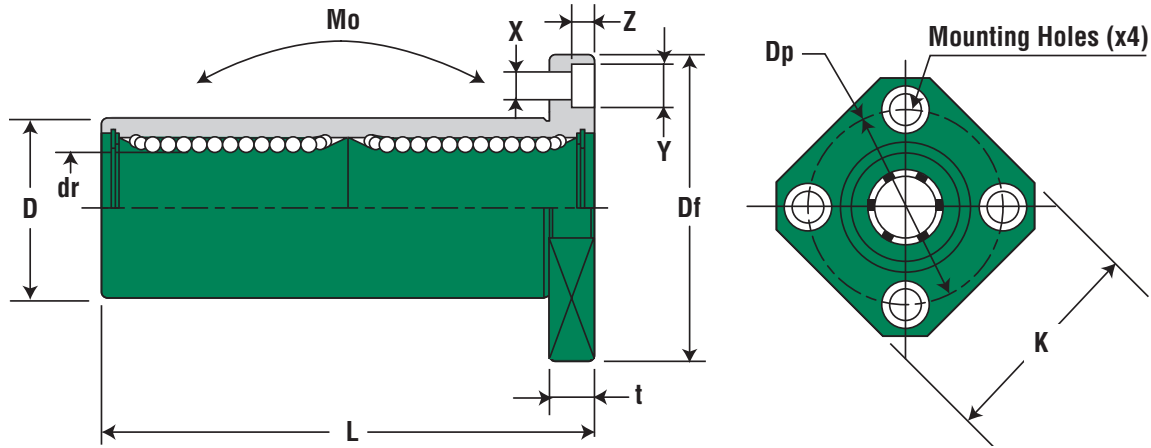

JPK-W SERIES - DIMENSIONAL INFORMATION

NOMINAL SHAFT DIAMETER (mm)	PART NUMBER	MAJOR DIMENSIONS & TOLERANCES							
		BALL CIRCUIT	WEIGHT (g)	dr (mm)	TOLERANCE (μ m)	D (mm)	TOLERANCE (μ m)	L (mm)	TOLERANCE (mm)
8	JPK8GW	4	43	8	0 -10	15	0 -13	45	± 0.3
12	JPK12GW		90	12		21	0 -16	57	
16	JPK16GW	5	165	16		28		70	
20	JPK20GW		225	20	0 -12	32	0 -19	80	
25	JPK25GW	500	25	40		112			
30	JPK30GW	590	30	45		123			
40	JPK40GW	6	1,380	40	0 -15	60	0 -22	151	
50	JPK50GW		3,400	50		80	192		
60	JPK60GW		4,060	60	0 -20	90	0 -25	209	

Flange Mount

The data and specifications in this publication have been carefully compiled and are believed to be accurate and correct. However, it is the responsibility of the user to determine and ensure the suitability of Pacific Bearing® products for a specific application. Pacific Bearing's only obligation will be to repair or replace without charge, any defective components if returned promptly. No liability is assumed beyond such replacement. *Consult www.pacific-bearing.com for the latest technical updates.



Simplicity® Ball Bearings

Square Flange Mount Double Wide - JIS Metric

Linear Motion Systems

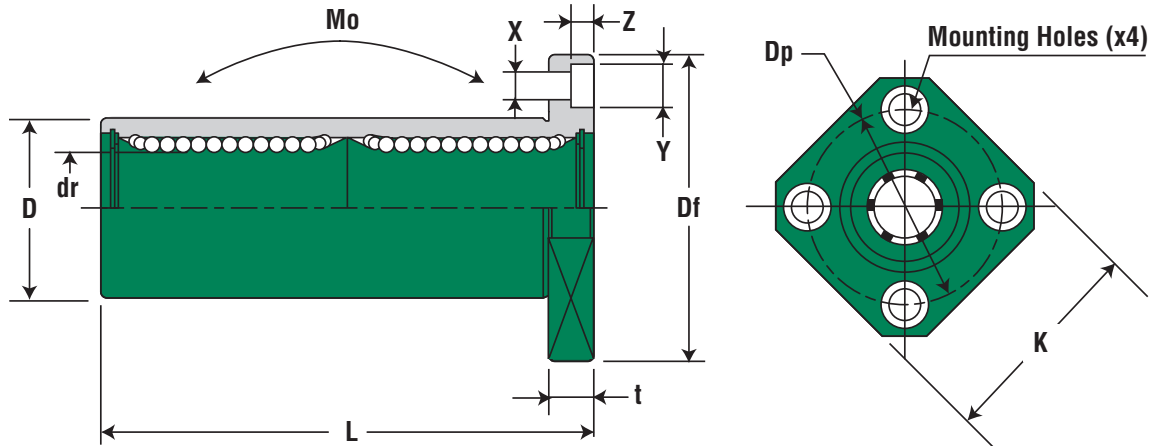

JPK-W SERIES - DIMENSIONAL INFORMATION (cont.)

(Standard Steel Finish)

MAJOR DIMENSIONS & TOLERANCE							LOAD RATING			
Df (mm)	K (mm)	t (mm)	Dp (mm)	X x Y x Z (mm)	ECCENTRICITY ID to OD (inch/ μ m)	PERPENDICULARITY FLANGE FACE to ID (inch/ μ m)	DYNAMIC C (N)	STATIC Co (N)	ALLOWABLE STATIC MOMENT Mo (N-m)	NOMINAL SHAFT DIAMETER (mm)
32	25	5	24	3.5 x 6 x 3.1	15	15	431	784	4.3	8
42	32	6	4.5 x 7.5 x 4.1	813			1,570	10.9	12	
48	37			38			1,230	2,350	19.7	16
54	42	8	43	5.5 x 9 x 5.1	20	20	1,400	2,740	26.8	20
62	50						51	1,560	3,140	43.4
74	58		60	6.6 x 11 x 6.1			2,490	5,490	82.8	30
96	75	13	78	9 x 14 x 8.1	25	25	3,430	8,040	147	40
116	92						98	6,080	15,900	397
134	106	18	112	11 x 17 x 11.1			30	30	7,550	20,000

Flange Mount

The data and specifications in this publication have been carefully compiled and are believed to be accurate and correct. However, it is the responsibility of the user to determine and ensure the suitability of Pacific Bearing® products for a specific application. Pacific Bearing's only obligation will be to repair or replace without charge, any defective components if returned promptly. No liability is assumed beyond such replacement. *Consult www.pacific-bearing.com for the latest technical updates.



Simplicity® Ball Bearings

Round Flange Center Mount - JIS Metric

Linear Motion Systems

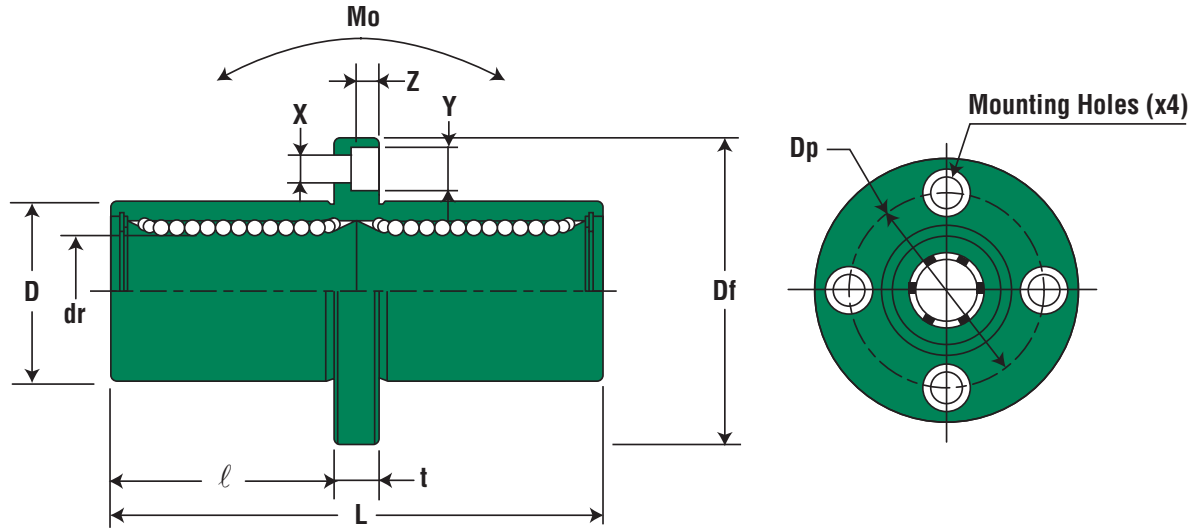

JPFC SERIES - DIMENSIONAL INFORMATION

NOMINAL SHAFT DIAMETER (mm)	PART NUMBER	MAJOR DIMENSIONS & TOLERANCES								
		BALL CIRCUIT	WEIGHT (g)	dr (mm)	TOLERANCE (μm)	D (mm)	TOLERANCE (μm)	L (mm)	TOLERANCE (mm)	l (mm)
8	JPFC8G	4	51	8	0 -10	15	0 -13	45	± 0.3	20.0
12	JPFC12G		110	12		21	0 -16	57		25.5
16	JPFC16G	5	190	16		28		70		32.0
20	JPFC20G		260	20	32	80	36.0			
25	JPFC25G	6	540	25	0 -12	40	0 -19	112		52.0
30	JPFC30G		680	30	45	123	56.5			
40	JPFC40G		1,570	40	60	151	69.0			
50	JPFC50G	3,600	50	0 -15	80	0 -22	192	89.5		
60	JPFC60G	4,500	60	0 -20	90	0 -25	209	95.5		

Flange Mount

The data and specifications in this publication have been carefully compiled and are believed to be accurate and correct. However, it is the responsibility of the user to determine and ensure the suitability of Pacific Bearing® products for a specific application. Pacific Bearing's only obligation will be to repair or replace without charge, any defective components if returned promptly. No liability is assumed beyond such replacement. *Consult www.pacific-bearing.com for the latest technical updates.



Simplicity® Ball Bearings

Round Flange Center Mount - JIS Metric

Linear Motion Systems

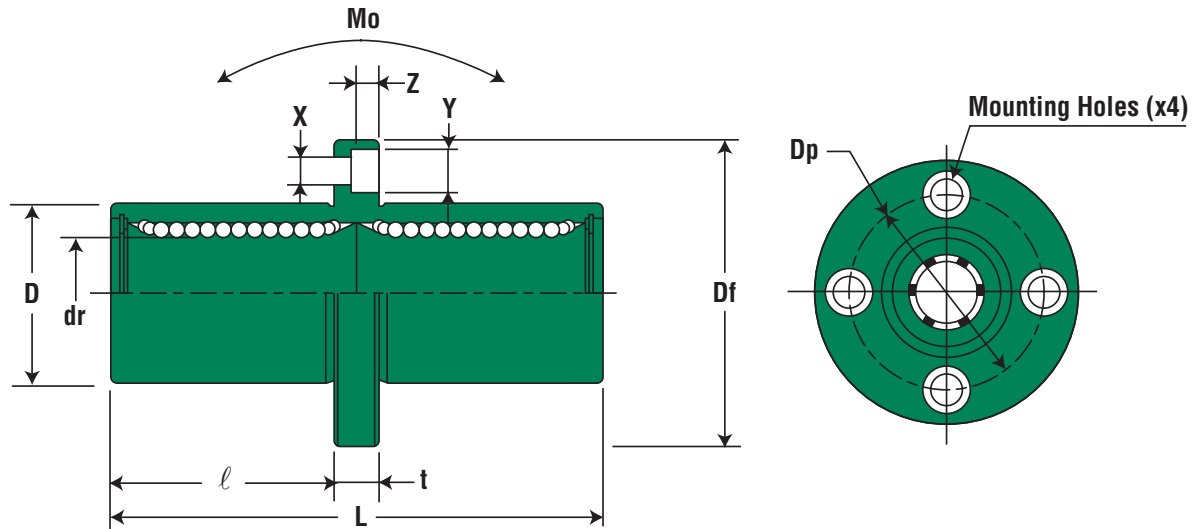

JPFC SERIES - DIMENSIONAL INFORMATION (cont.)

(Standard Steel Finish)

MAJOR DIMENSIONS & TOLERANCES						LOAD RATING			
Df (mm)	t (mm)	Dp (mm)	X x Y x Z (mm)	ECCENTRICITY ID to OD (inch/μm)	PERPENDICULARITY FLANGE FACE to ID (inch/μm)	DYNAMIC C (N)	STATIC Co (N)	ALLOWABLE STATIC MOMENT Mo (N-m)	NOMINAL SHAFT DIAMETER (mm)
32	5	24	3.5 x 6 x 3.1	15	15	431	784	4.3	8
42	6	32	4.5 x 7.5 x 4.1			813	1,570	10.9	12
48		38				1,230	2,350	19.7	16
54	8	43	5.5 x 9 x 5.1	20	20	1,400	2,740	26.8	20
62		51				1,560	3,140	43.4	25
74		10				60	6.6 x 11 x 6.1	2,490	5,490
96	13	78	9 x 14 x 8.1	25	25	3,430	8,040	147	40
116		98				6,080	15,900	397	50
134		18				112	11 x 17 x 11.1	7,550	20,000

Flange Mount

The data and specifications in this publication have been carefully compiled and are believed to be accurate and correct. However, it is the responsibility of the user to determine and ensure the suitability of Pacific Bearing® products for a specific application. Pacific Bearing's only obligation will be to repair or replace without charge, any defective components if returned promptly. No liability is assumed beyond such replacement. *Consult www.pacific-bearing.com for the latest technical updates.

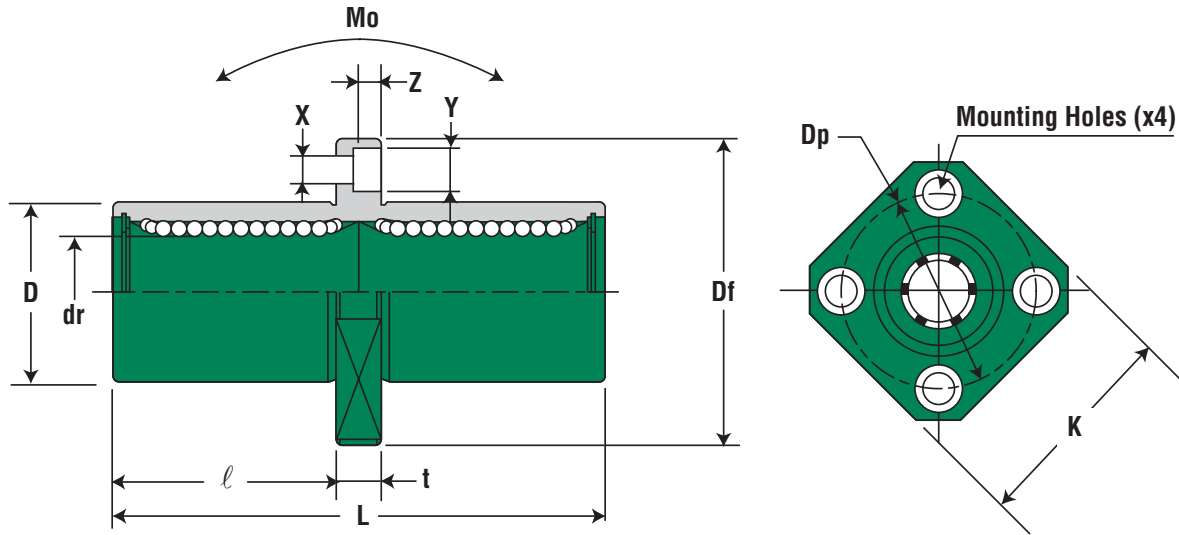

JPKC SERIES - DIMENSIONAL INFORMATION

PART NUMBER		MAJOR DIMENSIONS & TOLERANCES								
NOMINAL SHAFT DIAMETER (mm)	STANDARD POLYMER CAGE	BALL CIRCUIT	WEIGHT (g)	dr (mm)	TOLERANCE (μm)	D (mm)	TOLERANCE (μm)	L (mm)	TOLERANCE (mm)	l (mm)
8	JPKC8G	4	43	8	0 -10	15	0 -13	45	± 0.3	20
12	JPKC12G		90	12		21	0 -16	57		25.5
16	JPKC16G		165	16		28	70	32		
20	JPKC20G	5	225	20	32	80	36			
25	JPKC25G		500	25	40	0 -19	112	52		
30	JPKC30G	6	590	30	45	123	56.5			
40	JPKC40G		1,380	40	60	0 -22	151	69		
50	JPKC50G		3,400	50	80	192	89.5			
60	JPKC60G		4,060	60	90	0 -25	209	95.5		

The data and specifications in this publication have been carefully compiled and are believed to be accurate and correct. However, it is the responsibility of the user to determine and ensure the suitability of Pacific Bearing® products for a specific application. Pacific Bearing's only obligation will be to repair or replace without charge, any defective components if returned promptly. No liability is assumed beyond such replacement. *Consult www.pacific-bearing.com for the latest technical updates.

Flange Mount



Simplicity® Ball Bearings

Square Flange Center Mount - JIS Metric

Linear Motion Systems

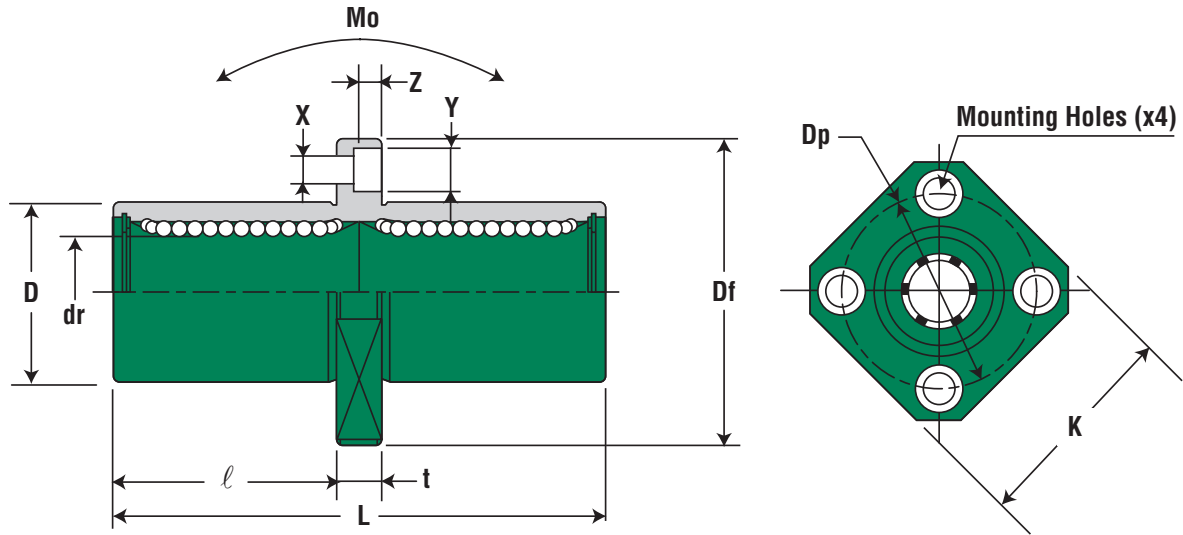

JPKC SERIES - DIMENSIONAL INFORMATION (cont.)

(Standard Steel Finish)

MAJOR DIMENSIONS & TOLERANC							LOAD RATING			
Df (mm)	K (mm)	t (mm)	Dp (mm)	X x Y x Z (mm)	ECCENTRICITY ID to OD (inch/μm)	PERPENDICULARITY FLANGE FACE to ID (inch/μm)	DYNAMIC C (N)	STATIC Co (N)	ALLOWABLE STATIC MOMENT Mo (N-m)	NOMINAL SHAFT DIAMETER (mm)
32	25	5	24	3.5 x 6 x 3.1	15	15	431	784	4.3	8
42	32	6	32	4.5 x 7.5 x 4.1			813	1,570	10.9	12
48	37		38				1,230	2,350	19.7	16
54	42	8	43	5.5 x 9 x 5.1	20	20	1,400	2,740	26.8	20
62	50		51				1,560	3,140	43.4	25
74	58	10	60	6.6 x 11 x 6.1			2,490	5,490	82.8	30
96	75	13	78	9 x 14 x 8.1	25	25	3,430	8,040	147	40
116	92		98				6,080	15,900	397	50
134	106	18	112	11 x 17 x 11.1			30	30	7,550	20,000

Flange Mount

The data and specifications in this publication have been carefully compiled and are believed to be accurate and correct. However, it is the responsibility of the user to determine and ensure the suitability of Pacific Bearing® products for a specific application. Pacific Bearing's only obligation will be to repair or replace without charge, any defective components if returned promptly. No liability is assumed beyond such replacement. *Consult www.pacific-bearing.com for the latest technical updates.



PRODUCT OVERVIEW



- The Simplicity® ball bearing consists of an outer cylinder, ball retainer, balls and two end rings. The ball retainer which holds the balls in the recirculating tracks is held inside the outer cylinder by end rings.
- Those parts are assembled to optimize their required functions.
- The outer shell is heat treated to ensure long life.
- The ball retainer is molded from a durable polymer to ensure smooth motion.

FEATURES

High Precision and Rigidity -

The Simplicity® ball bearing is produced from a solid steel outer cylinder and incorporates an industrial strength polymer retainer.

Ease of Assembly -

The standard type of Simplicity® ball bearing can be loaded from any direction. Precision control is possible using only the shaft supporter, and the mounting surface can be machined easily.

Ease of Replacement -

Simplicity® ball bearing of each type are completely interchangeable because of their standardized dimensions and strict precision control. Replacement because of wear or damage is therefore easy and accurate.

Variety of Types -

PBC offers a full line of Simplicity® ball bearings: the standard, integral single-retainer closed type, the clearance adjustable type and the open types. The user can choose from among these according to the application requirements to be met.

ORDERING INFORMATION

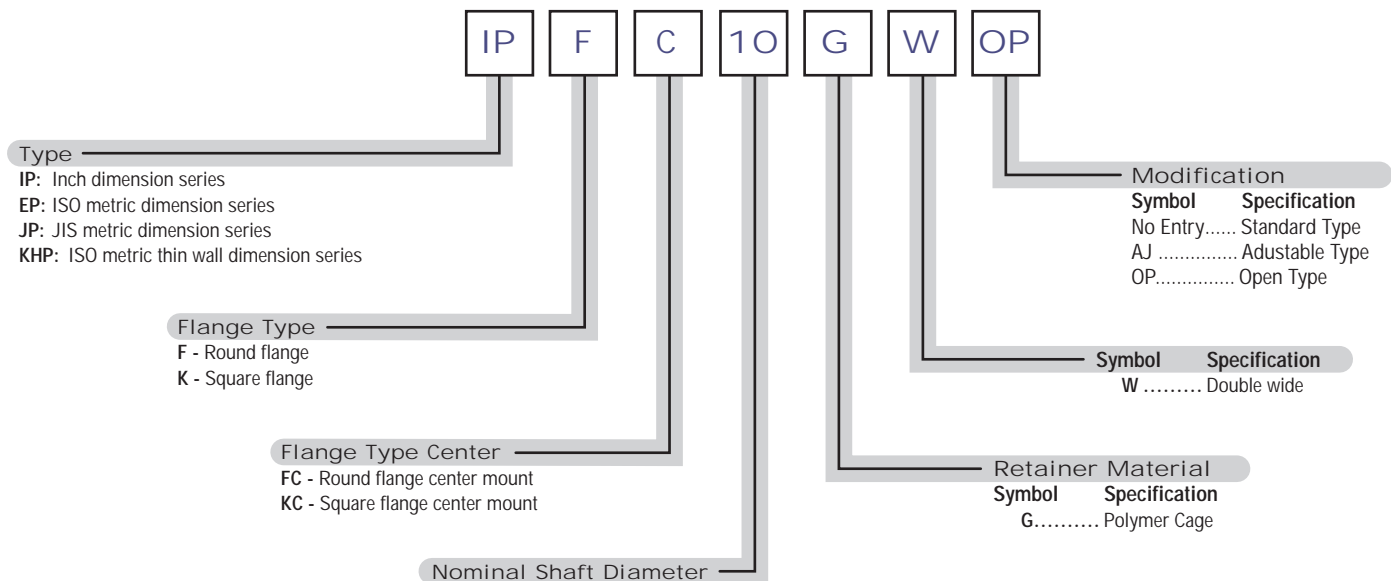

NOTE: Precision of inscribed circle diameters and outside diameters for the clearance adjustable type (...-AJ) and the open type (...-OP) indicates the value obtained before the corresponding type is subjected to cutting process.

The data and specifications in this publication have been carefully compiled and are believed to be accurate and correct. However, it is the responsibility of the user to determine and ensure the suitability of Pacific Bearing® products for a specific application. Pacific Bearing's only obligation will be to repair or replace without charge, any defective components if returned promptly. No liability is assumed beyond such replacement. *Consult www.pacific-bearing.com for the latest technical updates.



LOAD RATING AND LIFE EXPECTANCY

The life (L) of a linear bushing can be obtained from the following equation with the basic dynamic load rating and the load applied to the bush:

$$L = \left(\frac{f_H \cdot f_T \cdot f_C \cdot C}{f_W \cdot P} \right)^3 \cdot 50 \text{ ————— } 1$$

- L : Rated life (km/in.)
- C : Basic dynamic load rating (N/#)
- P : Working load (N/#)
- f_w : Load coefficient
- f_H : Hardness factor (see page ???)
- f_T : Temperature coefficient (see page ???)
- f_C : Contact coefficient (see page ???)

The lifespan (L_h) of a linear ball bushing in hours can be obtained by calculating the traveling distance per unit time. The lifespan can be obtained from the following equation if the stroke length and the number of strokes are constant:

$$L_h = \left(\frac{L \cdot 10^3}{2 \cdot s \cdot n_1 \cdot 60} \right) \text{ ————— } (2)$$

- L_h : Lifespan (hr)
- L : Rated life (km/in.)
- s : Stroke length (m/in.)
- n₁ : Number of strokes per minute (cpm)

RELATION BETWEEN BALL CIRCUITS AND LOAD RATING

The Simplicity® linear ball bearings are constructed so that the ball circuits are spaced equally. The load rating varies according to the loaded position. The load ratings of the linear ball bearings from the dimensional tables are per track and increased loading can be achieved by equally sharing the load between the tracks.

The following table shows the increased value by the number of ball circuits in such cases:

LOAD RATING

Basic Dynamic Load Rating (C) -

This term is arrived at based on an evaluation of a number of identical linear systems individually run in the same conditions, if 90% of them can run with the load (with a constant value in a constant direction) for a distance of 50 km without damage caused by rolling fatigue. This is the basis of the rating.

Allowable Static Moment (M) -

This term defines the allowable limit value of static moment load, with reference to the amount of permanent deformation similar to that used for evaluation of basic rated load (C₀).

Static Safety Factor (f_s) -

This factor is used based on the application condition as shown in Table 1.

TABLE 1 - STATIC SAFETY FACTORS

CONDITION OF USE	LOW LIMIT OF f _s
When the shaft has less deflection and shock	1 to 2
When elastic deformation should be considered with respect to cantilever load	2 to 4
When the equipment is subject to vibration and impacts	3 to 5

Basic Static Load Rating (C₀) -

This term defines a static load such that, at the contacting position where the maximum stress is exercised, the sum of the permanent deformation of the rolling elements and that of the rolling plane is 0.0001 time of the diameter of the rolling elements.

Number of Rows	4	5	6
C ₀ Load Rating Specified on the Tables			
C _{0max} Maximum Load Rating			
Load Ratio C _{0max} /C ₀	1.414	1.463	1.280

NOTES: 3 track bearing is equal.
Open bearing load is de-rated by 50% if going against the opening.

The data and specifications in this publication have been carefully compiled and are believed to be accurate and correct. However, it is the responsibility of the user to determine and ensure the suitability of Pacific Bearing® products for a specific application. Pacific Bearing's only obligation will be to repair or replace without charge, any defective components if returned promptly. No liability is assumed beyond such replacement. *Consult www.pacific-bearing.com for the latest technical updates.



CLEARANCE & FIT

Standard-type Simplicity® linear ball bearings matched to a shaft that provides inadequate clearance may result in early bearing failure and/or rough linear motion. The clearance adjustable linear ball bearings and open linear ball bearings can be adjusted when assembled in the housing by controlling the housing bore. However, too much clearance will increase

the deformation of the linear ball bearing, which will affect its precision and life. Therefore, the appropriate clearance between the ball bearing and shaft, and the appropriate linear ball bearing housing bore are required based on application. Table 2 shows recommended fit of the linear ball bearing:

TABLE 2

MODEL	DIVISION	SHAFT		HOUSING	
		NORMAL FIT	TRANSITIONAL	LOOSE FIT	TIGHT FIT
JP	High Precision	g6	h6	H7	J7
EP	High Precision	g6	h6	H7	J7
IP	High Precision	h6	j6	H7	J7

SHAFT & HOUSING

To optimize performance of the Simplicity® linear ball bearing it is recommended that a high precision shaft and pillow block are required.

Shaft -

The rolling balls in the Simplicity® linear ball bearing are in line contact with the shaft surface. Therefore, the shaft dimensions, tolerance, surface finish, and hardness greatly affect the performance of the linear ball bearing. The shaft should be manufactured to the following tolerances:

- 1) Surface finish critically affects the smooth rolling of balls;
Shaft surface finish should be 6-8 micro (RA# 7.2 to 10.8 a 1.11 to 1 ratio).

- 2) Shaft hardness should be HRC 60 to 64. Hardness less than HRC 60 will decrease the life/load, see page 126.
- 3) Preload increases the frictional resistance slightly. If the preload is too tight, the deformation of the bearing sleeve will shorten the linear ball bearing's life.

Housing -

There are a wide variety of housings differing in design, machining, and mounting. See Table 2 (above) and the following section on mounting requirements.

MOUNTING

When inserting the linear ball bearing into the housing, do not hit the linear ball bearing on the end-retaining ring, but apply pressure either by hand or arbor on the linear ball bearing sleeve (See Fig.1) To insert the shaft into the mounted linear ball bearing, make sure the shaft is chamfered and be careful not to push on the balls by inserting the shaft at an angle. Note that if two shafts are used in parallel, the parallelism is an important factor to assure smooth linear movement and not damage the linear ball bearings.

Examples of Mounting -

The popular way to mount linear ball bearings is with a slight preload. Pacific Bearing recommends a slight clearance fit-up to ensure proper life. The examples, Figs. 2 to 6, show the inserted linear ball bearing using a variety of retention methods.

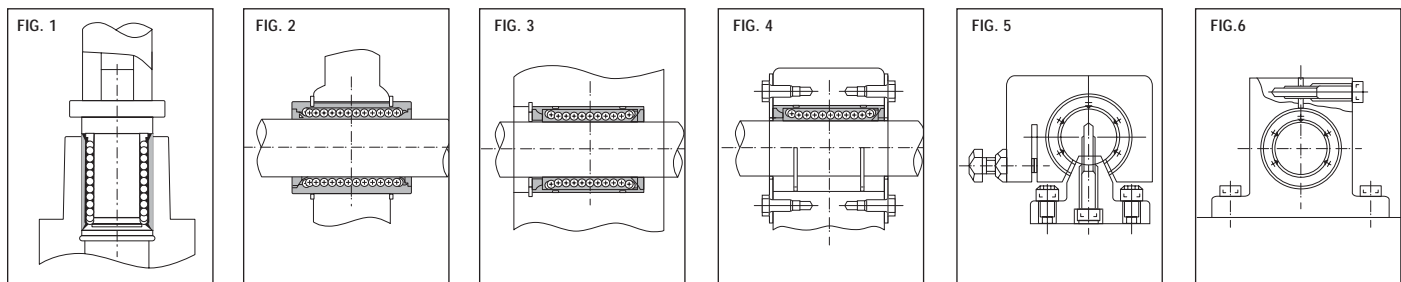

The data and specifications in this publication have been carefully compiled and are believed to be accurate and correct. However, it is the responsibility of the user to determine and ensure the suitability of Pacific Bearing® products for a specific application. Pacific Bearing's only obligation will be to repair or replace without charge, any defective components if returned promptly. No liability is assumed beyond such replacement. *Consult www.pacific-bearing.com for the latest technical updates.



RATING LIFE

Rating Life of the Linear System -

As long as the linear system reciprocates while being loaded, continuous stress acts on the linear system to cause flaking on the rolling bodies and planes because of material fatigue. The traveling distance of linear system until the first flaking occurs is called the life of the systems. The life of the system varies even for the systems of the same dimensions, structure, material, heat treatment and processing method, when used in the same conditions. This variation is brought about from the essential variations in the material fatigue itself. The rating life defined below is used as an index for the life expectancy of the linear system.

Rating Life (L) -

Rating life is the total travelling distance that 90% of a group of systems of the same size can reach without causing any flaking when they operate under the same conditions. The rating life can be obtained from the following equation with the basic dynamic load rating and the load on the linear system:

$$\text{For ball type: } L = \left(\frac{C}{P}\right)^3 \cdot 50 \text{ ————— (1)}$$

L : Rating life (km)

C: Basic dynamic load rating (N)

P : load (N)

Consideration and influence of vibration impact loads and distribution of load should be taken into account when designing a linear motion system. It is difficult to calculate

the actual load. The rating life is also affected by the operating temperature. In these conditions, the expression (1) is arranged as follows:

For ball type:

$$L = \left(\frac{f_H \cdot f_T \cdot f_C \cdot C}{f_W \cdot P}\right)^3 \cdot 50$$

L : Rating life (km)

f_H : Hardness factor (See Fig.1)

C : Basic dynamic load rating (N)

f_T : Temperature coefficient (See Fig.2)

P : Load (N)

f_C : Contact coefficient (See Table 2)

f_W : Load coefficient (See Table 3)

The rating life in hours can be calculated by obtaining the travelling distance per unit time. The rating life in hours can be obtained from the following expression when the stroke length and the number of strokes are constant:

$$L_h = \left(\frac{L \cdot 10^3}{2\ell_s \cdot n_1 \cdot 60}\right)$$

L_h : Rating life in hours (hr)

ℓ_s : Stroke length (m)

L : Rating life (km)

n₁ : No.of strokes per minute (cpm)

SAMPLE CALCULATIONS

1. Obtaining the rated life L and lifespan L_h of the Simplicity® linear ball bearing used in the following conditions:

Linear ball bearingEP20G
Stroke length50mm
Number of strokes per minute50cpm
Load per bush490N

The basic dynamic load rating of the linear ball bearing is 882N from the dimension tables. From equation (1), therefore, the rated life L is obtained as follows:

$$L = \left(\frac{f_H \cdot f_T \cdot f_C \cdot C}{f_W}\right)^3 \cdot 50 \quad f_H=f_T=f_C=f_W=1.0$$

$$= \left(\frac{882}{490}\right)^3 \cdot 50 = 292\text{km}$$

From equation (2), the lifespan L_h is obtained as follows:

$$L_h = \frac{L \cdot 10^3}{2 \cdot \ell_s \cdot n_1 \cdot 60} = \frac{292 \cdot 10^3}{2 \cdot 0.05 \cdot 50 \cdot 60} = 973\text{hr}$$

2. Select the linear ball bearing type by satisfying the following conditions:

Number of linear bushing used.....4
Stroke length.....1m
Traveling speed.....10m/min.
Number of strokes per minute5spm
Lifespan.....10,000hr
Total load980N

From equation (2), the traveling distance within the lifespan is obtained as follows:

$$L = 2 \cdot \ell_s \cdot n_1 \cdot 60 \cdot L_h = 6,000\text{km}$$

From equation (1), the basic dynamic load rating is obtained as follows:

$$C = \sqrt[3]{\frac{L}{50} \cdot \left(\frac{f_W}{f_H \cdot f_T \cdot f_C}\right)} \cdot P = 1492\text{N}$$

Assume the following with a pair of shafts each with two linear ball bearings: f_C = 0.81 f_W = f_T = f_H = 1

As a result, EP20G is selected from the dimension table as the Simplicity® linear ball bearing type satisfying the value of C.

The data and specifications in this publication have been carefully compiled and are believed to be accurate and correct. However, it is the responsibility of the user to determine and ensure the suitability of Pacific Bearing® products for a specific application. Pacific Bearing's only obligation will be to repair or replace without charge, any defective components if returned promptly. No liability is assumed beyond such replacement. *Consult www.pacific-bearing.com for the latest technical updates.



RATING LIFE (cont.)

Hardness Factor (f_H) -

The shaft must be sufficiently hardened when a linear bushing is used. If not properly hardened, permissible load is lowered and the life of the linear ball bearings will be shortened.

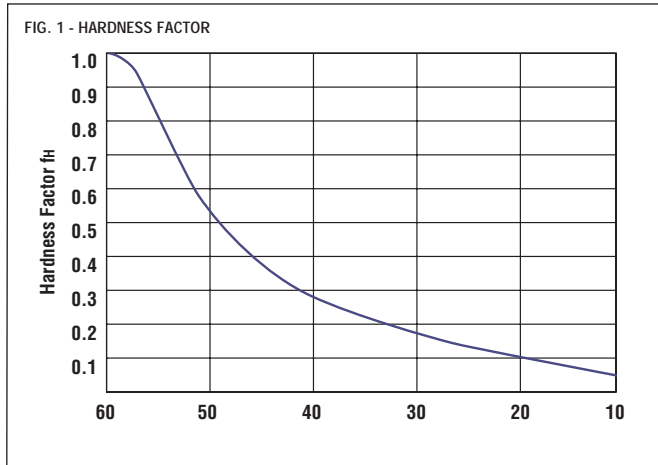

Temperature Coefficient (f_T) -

If the temperature of the linear system exceeds 100°C, hardness of the linear system and the shaft lowers to decrease the permissible load compared to that of the linear system used at room temperature. As a result, the abnormal temperature rise shortens the rating life.

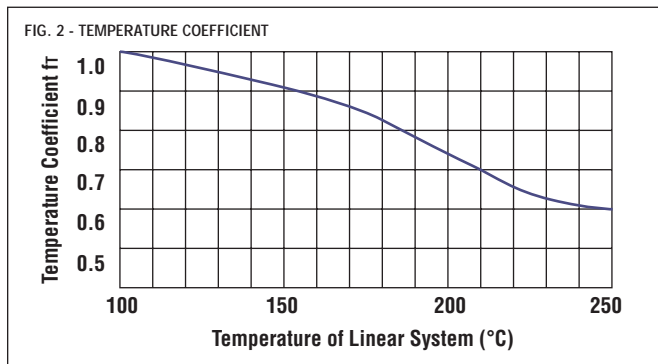

NOTES: Maximum temperature of plastic retainer 212°F or 100°C.
Maximum temperature 176° per Table 6.

Contact Coefficient (f_C) -

Generally two or more linear bearings are used on one shaft. Thus, the load on each linear system differs depending on each processing accuracy. Because the linear bushings are not loaded equally, the number of linear bushings per shaft changes the permissible load off the system.

TABLE 2 - CONTACT COEFFICIENT

NUMBER OF LINEAR SYSTEMS PER SHAFT	CONTACT COEFFICIENT f_C
1	1.00
2	0.81
3	0.72
4	0.66
5	0.61

Load Coefficient (f_W) -

When calculating the load on the linear system, it is necessary to accurately obtain object weight, inertial force based on motion speed, moment load, and each transition as time passes. However, it is difficult to calculate those values accurately because reciprocating motion involves the repetition of start and stop as well as vibration and impact. A more practical approach is to obtain the load coefficient by taking the actual operating conditions into account.

TABLE 3 - LOAD COEFFICIENT

OPERATING CONDITIONS	f_W
Operation at low speed (15m/min.or less) without impulsive shock from outside	1.0 to 01.5
Operation at intermediate speed (60m/min.or less) without impulsive shock	1.5 to 2.0
Operation at high speed (over 60m/min.) with impulsive shock from outside	2.0 to 3.5

The data and specifications in this publication have been carefully compiled and are believed to be accurate and correct. However, it is the responsibility of the user to determine and ensure the suitability of Pacific Bearing® products for a specific application. Pacific Bearing's only obligation will be to repair or replace without charge, any defective components if returned promptly. No liability is assumed beyond such replacement. *Consult www.pacific-bearing.com for the latest technical updates.



FRICITIONAL RESISTANCE

The static frictional resistance of the Simplicity® linear system is so low that it is only slightly different from the kinetic frictional resistance, enabling smooth linear movement from low to high speeds. In general, the frictional resistance is expressed by the following equation.

$$F = \mu \cdot W + f$$

F : Frictional resistance μ : Coefficient of friction
 W : Load weight f : Sealing resistance

The frictional resistance of each PBC linear system depends on the model, load weight, speed, and lubricant. The sealing resistance depends on the lip interference and lubricant, regardless of the load weight. The sealing resistance of one linear system is about 200 to 500 gf. The coefficient of friction depends on the load weight, moment load, and preload.

TABLE 5 - COEFFICIENT OF LINEAR SYSTEM FRICTIONS (μ)		
LINEAR SYSTEM TYPE	MODELS	COEFFICIENT OF FRICTION (μ)
Linear Bearing	JP, EP, IP	0.002 to 0.003

AMBIENT WORKING TEMPERATURE

The ambient working temperature range for each PBC linear system depends on the model. Consult PBC on use outside the recommended temperature range.

Temperature conversion equation:

$$C = \frac{5}{9}(F - 32) \quad F = 32 + \frac{9}{5}C$$

TABLE 6 - AMBIENT WORKING TEMPERATURE		
LINEAR SYSTEM TYPE	MODELS	AMBIENT WORKING TEMPERATURE
Linear Bushing	JP, EP, IP	-20 to 80°C, 176°F

LUBRICATION AND DUST PREVENTION

Using PBC linear systems without lubrication increases the abrasion of the rolling elements, shortening the life span. The PBC linear systems therefore require appropriate lubrication. For lubrication PBC recommends turbine oil conforming to ISO Standards G32 to G68 or lithium base soap grease No.2. Some PBC linear systems are sealed to block dust out and seal lubricant in. If used in a harsh or corrosive environment a protective cover should be used.

The data and specifications in this publication have been carefully compiled and are believed to be accurate and correct. However, it is the responsibility of the user to determine and ensure the suitability of Pacific Bearing® products for a specific application. Pacific Bearing's only obligation will be to repair or replace without charge, any defective components if returned promptly. No liability is assumed beyond such replacement. *Consult www.pacific-bearing.com for the latest technical updates.



PRODUCT OVERVIEW



Pacific Bearing is a worldwide supplier of innovative linear and rotary motion solutions. Since our founding in 1982, when Pacific Bearing pioneered the first two-piece bonded Simplicity® linear bearing, we have built a solid reputation for providing innovative application solutions solving the toughest linear and rotary problems. The success and continued demand for the Simplicity® self-lubricated linear and rotary bearings, has broadened our market opportunities and fostered new product introductions. The Simplicity® product family has expanded to include thrust and sleeve bearings, die set bushings, square bearings, pillow blocks, and a complete line of European and Japanese metric bearings.

Today, Pacific Bearing's design innovation extends beyond plane bearings. The introduction of FrelonGOLD® bearing liner material in 1998, created the opportunity to introduce Feather Shafting - a new lightweight ceramic coated roundway shaft that is approximately 1/3 the weight of steel shafting plus, providing the smoothest and quietest linear and rotary motion. Combining both Simplicity® and Feather Shaft® technologies, Pacific Bearing created Dolphin Guides® and Mini Rail® Linear Guides. They feature our simple, cost effective, two-piece linear guides that afford the design engineer, integration, flexibility, and direct compatibility with competitive Linear Guide technologies.

Redi-Rail® was created to meet the industry demand for faster, lighter and quieter linear motion applications. Combining lightweight structural components, precision steel inner raceways, and high-speed self lubricated roller bearings; Redi-Rail delivers high-speed performance (8 meters/second), with continuous rail lengths available up to 19 feet (6m). Redi-Rail® Linear guides are also configured in V-Guide Systems to provide high speed, in moderate load capacity in harsh environments.

Hevi-Rail®, heavy-duty Linear Bearing Systems provide high load capacity and simple installation. Hevi-Rail is a sealed, self-lubricated bearing that is capable of addressing both radial and axial loads up to 41 KN. Utilizing Hevi-Rail combination bearings, coupled with our complete line of accessories; eliminates components, reduces installation time, and subsequently lowers costs.

Pacific Bearing now offers its linear motion components completely assembled in pre-engineered Systems, Slides and Stages. We also offer ball screw, lead screw, and belt drives in addition to linear motors, and cylinders. Catalogue systems are available in a few days and custom systems are also quickly available.

Pacific Bearing is proud to introduce its light-weight polymer sleeve and flange bearings to their product family. Polymer bearings are used in a variety of applications with specially formulated compounds with the following advantages:

Main advantages of plane polymer bearings:

- Absorb vibrations
- Anti-corrosive
- Chemically resistant
- Lightweight
- Provide additional functions (integral seals, grease retention pockets etc.)
- Highly economic because of:
 - Lower unit costs
 - Fewer components
 - No maintenance costs

Additional advantages of compound plane bearings:

- Modified for various applications
- Low density
- Adjustability with electric insulation and conductivity
- Suitable for dry runs
- Friendly to edge loading
- Can show magnetic properties
- Resistant to ionizing radiation

The data and specifications in this publication have been carefully compiled and are believed to be accurate and correct. However, it is the responsibility of the user to determine and ensure the suitability of Pacific Bearing® products for a specific application. Pacific Bearing's only obligation will be to repair or replace without charge, any defective components if returned promptly. No liability is assumed beyond such replacement. *Consult www.pacific-bearing.com for the latest technical updates.



MAIN ADVANTAGES

Maintenance-free self-lubricated:

PBC compounds lubricants in balanced ratios into the polymer matrix and ensure through fiberate micro-wear during running in for clean and continuous auto lubrication. During micro-wear a transfer coating is built enabling optimal sliding performance. The basic polymers and their additives already own good tribological properties.

Long service life:

The homogeneous structure of the compound plane bearings prevent thin run or wear layers which would shorten service life right from the beginning. The basic polymer with its mainly synthetic reinforcement additives forms an intimate matrix for other additives. There is no abrasive wear of the shafts because the commonly used glass fibers have been removed.

Low friction:

Static and dynamic coefficients of friction are close to each other due to the high amount of PTFE and other special additives in the compounds. Thus, we ensure stick-slip-free running at lower speeds. The plane bearing also runs with much less noise. The frictional behavior of the compound plane bearings depends mainly on temperature, sliding speeds, types of movement and loads. Surface structure and the circumstances of dry running or greasing standards substantially influence frictional behavior. Through the appropriate lubrication the coefficient of friction can be reduced even further.

High dimensional stability:

All compound plane bearings take in virtually no water, which can be disregarded to dimensional accuracy in connection with the installation. Fiber strengthening reduces thermal expansion/contraction and improves the press-fit at higher temperatures.

Minimal wear:

Compound plane bearings are extremely wear resistant in rotating and axial bearings as well as in hinge movements under high loads.



High loading capacity:

Our compound plane bearings can withstand immense forces and pressures. As well as edge loads, which do not cause problems in contrast to common plane bearings made of non-ferrous metals or composite materials. Depending on the compound chosen, high pressures are also permissible.

Broad temperature range:

Depending on the material temperatures of -200°C/-328°F up to +250 °C can be withstood during application. Always check the compound specifications in each application with regard to temperature tolerances.

Improved thermal conductivity:

Polymer compound plane bearings show an improved thermal conductivity. Higher rpm/sfm during continuous operation are possible thanks to a better press-fit of the plane bearing in its housing. This is achieved through fiber strengthening.

PLANE BEARINGS FOR ALL APPLICATIONS

Pacific Bearing produces compound plane bearings through an injection molding process.

We can help you select a suitable material for a specific application from our wide range of materials. Our technical staff will support you at every step of the way. PBC will find the best compound for your application – with regard to costs as well as effectiveness/performance.

Whether you are looking for standard parts or custom/proprietary components we can provide standard plane bearings. Special components and seals are available as well.

Standard Plane Bearings:

Standard bearings are stocked in compounds A and E:

- Bushings
- Flanged bushings
- Thrust washers
- Bushings with integral seals

You can select exact dimensions from the separate dimension table.

Plane Bearings with Integral Seals:

Plane bearings with integral seals have proven superior in sustaining the basic advantages of our compound plane bearings even in tough environments.

The advantages:

- Integral seals keep away dirt and water from the bearing
- Initial lubrication is suggested
- Safe from corrosion

As a standard we provide bearings with double-sided integral seals.

The data and specifications in this publication have been carefully compiled and are believed to be accurate and correct. However, it is the responsibility of the user to determine and ensure the suitability of Pacific Bearing® products for a specific application. Pacific Bearing's only obligation will be to repair or replace without charge, any defective components if returned promptly. No liability is assumed beyond such replacement. *Consult www.pacific-bearing.com for the latest technical updates.



HIGH PERFORMANCE PLANE BEARINGS

High performance plane bearings are a specialty of Pacific Bearing, which is distinguished by a quality-analytic separation of the bearing function. We manufacture them by multi cavity injection molding process. These are high filled and form a stable basic body and a sliding layer with the most favorable wear and friction values. Additionally, we include specially arrayed grease retention pockets. Integrated elastomer integral seals complement these bearings.

The layers of our high performance plane bearings are built up as follows:

- **Outer layer:** A high-filled basic body guarantees press-fit and pressure capacity with high temperatures as well as with high stress
- **Inner layer:** Tribologically modified sliding layer for optimal wear and friction characteristics

They show the particular qualities of:

- Increased application possibilities
- Corrosion resistance
- Low weight
- Optimized performance
- Optimal adaptation to your requirements through suitable combinations of materials and design

SPECIAL PARTS

We can deliver special forms and dimensions of parts under wear and friction demands, which we design, and manufacture individually along your requirements. Our service covers the material side as well as dimensional interpretation of the component.



Other special components are, for example:

- | | | |
|--|--|---------------------------|
| • Gearwheels, tooth racks | • Spherical plane bearings/ components | • Sliding elements |
| • Plane bearings with integrated grease retention pockets and integral seals | • Split bushings | • Casters |
| • Slide ring seals | • High performance plane bearings | • Calotte bearings |
| • Half sockets, ball sockets | • Thrust washers | • Spindle nuts |
| | • Multi-component parts | • Wipers |
| Our compound plane bearings markets: | | |
| • Automotive | • Semiconductor production lines | • Furniture |
| • Agricultural machinery | • Electric motors | • Industrial engineering |
| • Mechanical engineering | • Textile machinery | • Pharmaceutical industry |
| • Hydraulics | • Medical and laboratory technology | • Conveyor technology |
| • Light engineering | • Pumps | • Galvanization equipment |
| • Valves | • Printing presses | • Office equipment |
| • Chemical apparatus | • Paper making machines | • Automation |
| • Pneumatics | • Household appliances | |
| • Oven construction | • Food industry | |

HOW TO CHOOSE THE BEST MATERIAL

The optimal application of a plane bearing in a system essentially depends on temperature, sliding speed, the occurring loads and environmental influences. We offer a wide spectrum of materials for the most varied applications. The technical data should give you an orientation and simplify the choice. In general, testing is advised.

With only few exceptions we dispense with the use of glass fibers, which considerably enhances sliding performance and increases service life. Nevertheless, with synthetic fiber reinforcement the press-fit in housing shows increased temperature dependence. Hence, continuous use temperature should as a rule not exceed 60% of the maximum sliding surface temperature if special fixation offered or safety in the mounting arrangement is relinquished.

Our technical staff not only offer you a wide choice of materials but we can provide additional more detailed technical data. Apart from the material offered we also have access to all the other commonly used polymers or we can use some suitable material from our own Value Added Polymer series of compounds. Furthermore, we can design the optimal material for your demands in our in-house developing department and then produce the new material.

The data and specifications in this publication have been carefully compiled and are believed to be accurate and correct. However, it is the responsibility of the user to determine and ensure the suitability of Pacific Bearing® products for a specific application. Pacific Bearing's only obligation will be to repair or replace without charge, any defective components if returned promptly. No liability is assumed beyond such replacement. *Consult www.pacific-bearing.com for the latest technical updates.



COMPOUND		A	E	B	C	D	F	G
BASIS POLYMER		PEEK	PBT	PAI	PBT	PBT	POM	PPS
Additives		carbon fibers, graphite, PTFE	bronze, PTFE	graphite, PTFE, additives	aramide fibers, bronze, PTFE	long glass fibers, PTFE bronze, MoS ₂	PTFE	glass fibers, graphite, PTFE
color		black	brown	dark grey	olive	grey	white	light brown
density	g/cm ³	1.48	1.65	1.5	1.48	1.60	1.52	1.73
water vapor RT/50% rF	%	0.10	0.10	0.3	0.15	0.30	0.2	0.05
MECHANICAL PROPERTIES								
tensile strength	MPa	150	65	164	100	100	50	155
modulus of elasticity	GPa	6.5	2.8	6.6	4.2	6.4	2.5	13
specific load, static	MPa	150	70	150	80	90	60	120
THERMAL PROPERTIES								
thermal conductivity	W/mK	0.60	0.26	0.53	0.27	0.26	0.32	0.34
coefficient of thermal expansion	10 ⁻⁶ 1/K	30	14	25	13	25	120	30
max. sliding surface temperature	°C	-100 +250	-40 +100	-120 +240	-40 +120	-50 +130	-40 +80	-40 +200
max. temperature, unloaded	°C	+300	+150	+280	+200	+200	+140	+250
TRIBOLOGICAL PROPERTIES								
max. sliding speed, rotating	m/s	1.5	1.0	2.5	1.0	1.2	1.0	1.2
max. sliding speed, linear	m/s	5.0	3.0	4.5	4.0	4.5	4.0	4.5
max. pv-value	MPa • m/s	3.5	0.8	4.0	1.0	1.1	0.6	2.6
abstract		0.10 - 0.20	0.10 - 0.20	0.10 - 0.40	0.10 - 0.20	0.10 - 0.20	0.07 - 0.20	0.15 - 0.30
short description		Suitable for heavy loads Universal chemical resistance High temperatures	High loads Strong Machineable	Inexpensive material High temperature Special additives to improve the tribological properties	High loads Strong	High loads Strong Stable at high temperatures	This material is suitable mainly for the contact with food or applications in medical technology. The Compound is physiologically safe, corresponds to appropriate BGA/FDA recommendations.	High loads Strong Press-fit High temperatures
		STOCKED			PRODUCED TO ORDER			

The data and specifications in this publication have been carefully compiled and are believed to be accurate and correct. However, it is the responsibility of the user to determine and ensure the suitability of Pacific Bearing® products for a specific application. Pacific Bearing's only obligation will be to repair or replace without charge, any defective components if returned promptly. No liability is assumed beyond such replacement. *Consult www.pacific-bearing.com for the latest technical updates.



Chemical Resistance

CHEMICAL	A	E	B	C	D	F	G
Acetic acid, 5 %	+	+	+	+	+	+	+
Acetone	+	+		-	+	+	+
Ammonia, 10 %	-	-	-	-	-	+	+
Carbon tetrachloride	+	+	+	+	+	+	+
Caustic soda, 5 %	+	+	+	+	+	+	-
Diesel	+	+	+	+	+	+	+
Formic acid, 5 %	+	+	+	-	+	+	+
Gas	+	+	+	+	+	+	+
HFC-Water-Glycol, 70 °C	+	+	+	+	+	+	+
Hydrochloric acid, 5 %	+	-	+	-	-	-	-
Kerosene	+	+	+	+	+	+	+
Mineral oil, 70 °C	+	+	+	+	+	+	+
Nitric acid, 5 %	+	-	+	-	-	-	-
Paraffin	+	+	+	+	+	+	+
Seawater	+	+	+	+	+	+	+
Sulfuric acid, 5 %	+	+	+	+	+	-	+
Water	+	+	+	+	+	+	+
	STOCKED		PRODUCED TO ORDER				

+ Usage trouble-free, no corrosion expected

- Usage not recommended (chemical pit the compound and it is expected to react in a negative way)

On inquiry we will give you a detailed chemicals resistance list.



The data and specifications in this publication have been carefully compiled and are believed to be accurate and correct. However, it is the responsibility of the user to determine and ensure the suitability of Pacific Bearing® products for a specific application. Pacific Bearing's only obligation will be to repair or replace without charge, any defective components if returned promptly. No liability is assumed beyond such replacement. *Consult www.pacific-bearing.com for the latest technical updates.



These PBC materials (maintenance free) are standardized compounds for our plane bearings. Upon request we can also provide other standard and special bearings and sliding elements made of different materials or with divergent dimensions.

We solve a variety of problems and produce special forms as well as special dimensions according to your application needs even if they are not included in our tables.

Pacific Bearing® is always extending its standard mold family and adding proprietary features to custom molds as well.

COMPOUND A

Characteristics:

- Thermoplastic compound made of PEEK polymer matrix reinforced with synthetic fibers and modified with triboadditives
- Highly efficient high temperature material with high chemical and good wear resistance
- Recommended tolerance for press fit bushings: housing H7, shaft h7 - h9
- Color: black

Applications:

Industry – textile and knitting machinery, baking machinery, relay and control valves, powder coating equipment, chemical plants, armatures

Availability:

In stock – bearings, flanged bearings. Production to order – thrust washers, special parts of all kinds

Material structure:

PEEK + carbon fibers + PTFE + graphite

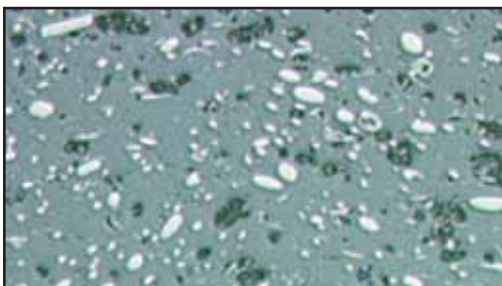

Grinding pattern A

Operation conditions:

- Dry good
- Oil lubricated. optimum
- Grease lubricated optimum
- Water lubricated optimum
- Medium lubricated optimum

COMPOUND E

Characteristics:

- Filled thermoplastic compound made of PBT polymer matrix and triboadditives
- Good sliding performance under moderate operational conditions
- The E standard program is interchangeable with bushings according to DIN1494/ISO3547
- Very cost-effective sliding material
- Recommended tolerance for press fit bushings: housing H7, shaft h7 - h9
- Color: brown

Applications:

Industry – medical equipment, textile machinery, transport devices, apparatus engineering, furniture, materials handling technology, electronics, valve technology, agricultural machinery

Availability:

In stock - bushings, flanged bushings, bushings with integrated sealings, thrust washers.

Production to order - special parts of all kinds

Material structure:

PBT + powdered bronze + PTFE

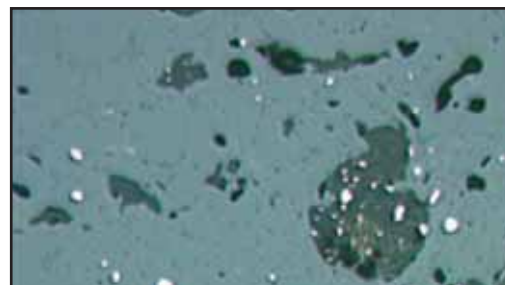

Grinding pattern E

Operational conditions:

- Dry good good
- Oil lubricated good
- Grease lubricated good
- Water lubricated less good
- Medium lubricated less good

The data and specifications in this publication have been carefully compiled and are believed to be accurate and correct. However, it is the responsibility of the user to determine and ensure the suitability of Pacific Bearing® products for a specific application. Pacific Bearing's only obligation will be to repair or replace without charge, any defective components if returned promptly. No liability is assumed beyond such replacement. *Consult www.pacific-bearing.com for the latest technical updates.



COMPOUND B

Characteristics:

- Injection-molded polyamidimide modified with special additives
- Irreversible cross-linking through by thermal treatment
- High temperature material for demanding components with low thermal expansion
- High toughness and mechanical consistency
- High wear resistance against vibrating oscillations
- Good chemical resistance
- Recommended tolerance for press fit bushings: housing H7, shaft h7 - h9
- Color: dark grey

Applications:

Automobile industry – automatic transmission, pumps, labyrinth seal in turbo blowers, piston rings, valve seats, integral seals

Industry – continuous furnace, cockles for coating, textile machinery

Other – aviation and astronautics, extreme high- and low-level temperature operations

Availability:

Production to order – bearings and special parts of all kinds

Material structure:

PAI + graphite + PTFE + additive

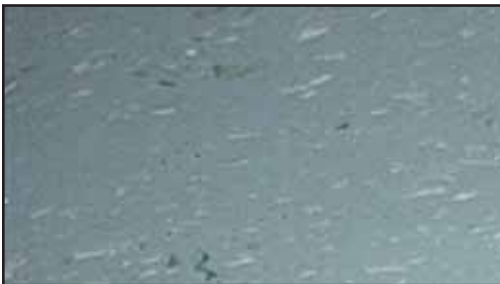

Grinding pattern B

Operational conditions:

- Drygood
- Oil lubricatedvery good
- Grease lubricatedgood
- Water lubricated.....good
- Medium.....good

COMPOUND C

Characteristics:

- Thermoplastic compound made of PBT polymer matrix reinforced with long glass fibers and modified with triboadditives
- Improved performance compared to E, as well as lower wear rate and less shrinkage
- Excellent press-fit by long glass fibers
- Recommended tolerance for press fit bushings: housing H7, shaft h7 - h9
- Color: olive

Applications:

Industry – medical equipment, textile machinery, transport devices, apparatus engineering, furniture, materials handling technology, electronics, valve technology, agricultural machinery

Availability:

Production to order – bushings, flanged bushings, bushings with integrated sealings, thrust washers special parts of all kinds.

Material structure:

PBT + powdered bronze + PTFE + aramid fibers

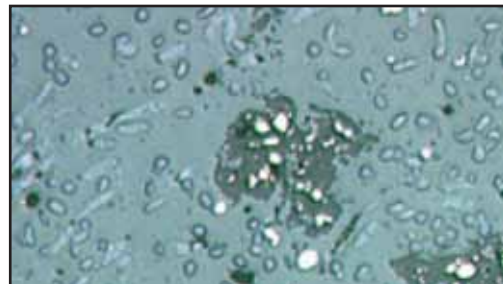

Grinding pattern C

Operational conditions:

- Drygood
- Oil lubricated.....good
- Grease lubricatedgood
- Water lubricated.....good
- Medium lubricatedless good

The data and specifications in this publication have been carefully compiled and are believed to be accurate and correct. However, it is the responsibility of the user to determine and ensure the suitability of Pacific Bearing® products for a specific application. Pacific Bearing's only obligation will be to repair or replace without charge, any defective components if returned promptly. No liability is assumed beyond such replacement. *Consult www.pacific-bearing.com for the latest technical updates.



COMPOUND D

Characteristics:

- Thermoplastic compound made of PBT polymer matrix reinforced with long glass fibers and modified with triboadditives
- Good sliding performance under moderate operational conditions
- Recommended tolerance for press fit bushings: housing H7, shaft h7 - h9
- Color: grey

Applications:

Automobile industry – hinges, guides for sliding and lifting covers

Industry – formed parts for machinery and apparatus engineering, adjustment devices

Availability:

Production to order – bushings, flanged bushings, thrust washers, special parts of all kinds

Material structure:

PBT + long glass fibers + powdered bronze + PTFE

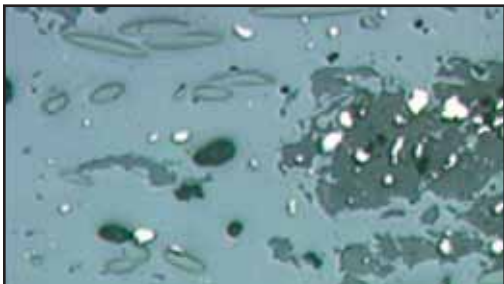

Grinding pattern D

Operational conditions:

- Drygood
- Oil lubricatedgood
- Grease lubricatedgood
- Water lubricatedless good
- Medium lubricatedless good

COMPOUND F

Characteristics:

- Thermoplastic compound made of made of POM polymer matrix with PTFE
- Corresponds to BGA/FDA recommendations. Suitable for contact with food.
- Recommended tolerance for press fit bushings: housing H7, shaft h7 - h9
- Color: white

Applications:

Industry – racks and packaging machines, pumps, butcher’s shop equipment, medical equipment

Availability:

Production to order – bushings, flanged bushings, thrust washers, bushings with integrated seals, special parts of all kinds

Material structure:

POM + PTFE

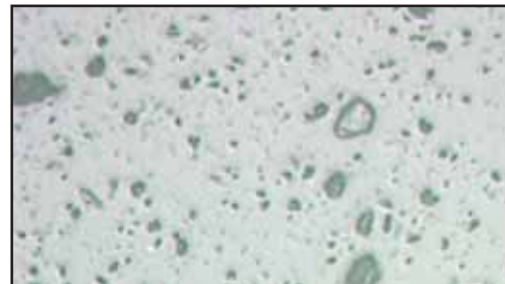

Grinding pattern F

Operational conditions:

- Dry goodgood
- Oil lubricatedgood
- Grease lubricatedgood
- Water lubricatedless good
- Medium lubricatedless good

The data and specifications in this publication have been carefully compiled and are believed to be accurate and correct. However, it is the responsibility of the user to determine and ensure the suitability of Pacific Bearing® products for a specific application. Pacific Bearing's only obligation will be to repair or replace without charge, any defective components if returned promptly. No liability is assumed beyond such replacement. *Consult www.pacific-bearing.com for the latest technical updates.



COMPOUND G

Characteristics:

- Thermoplastic compound made of PPS polymer matrix reinforced with glass fibers and triboadditives
- High hydrolysis and temperature resistance
- Good sliding performance under moderate operational conditions
- Recommended tolerance for press fit bushings: housing H7, shaft h7 - h9
- Color: beige

Applications:

Industry – various outdoor applications

Automobile industry – rear windscreen wiper, pump bearing

Availability:

Production to order – bushings, flanged bushings, thrust washer, special parts of all kinds

Material structure:

PPS + glass fibers + PTFE

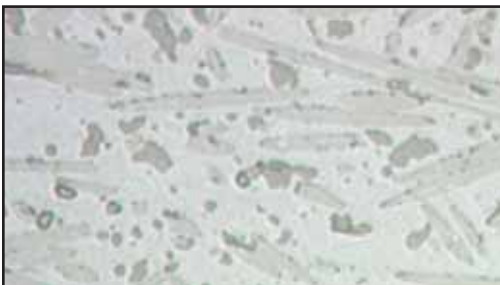

Grinding pattern G

Operational conditions:

- Dryless good
- Oil lubricatedgood
- Grease lubricatedgood
- Water lubricatedgood
- Medium lubricatedgood

The data and specifications in this publication have been carefully compiled and are believed to be accurate and correct. However, it is the responsibility of the user to determine and ensure the suitability of Pacific Bearing® products for a specific application. Pacific Bearing's only obligation will be to repair or replace without charge, any defective components if returned promptly. No liability is assumed beyond such replacement. *Consult www.pacific-bearing.com for the latest technical updates.



Simplicity® Plane Bearings

E - Polymer Series

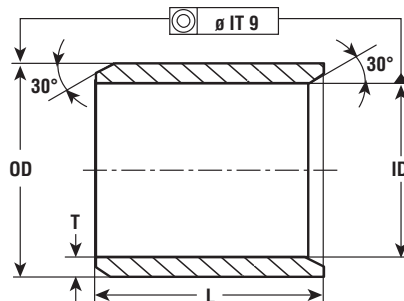

ORDERING INFORMATION

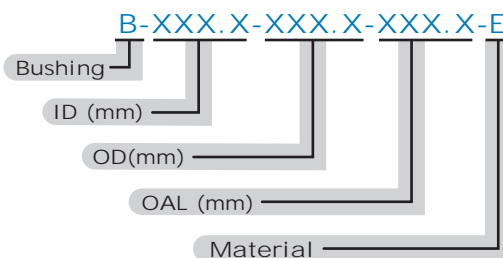

PART NUMBER	DIMENSIONS			WEIGHT [g]	FITTING TOLERANCE	
	ID [mm]	OD [mm]	L [mm]		HOUSING H7 [mm]	ID AFTER FITTING: F10 [mm]
B-002.0-003.5-003.0-E	2.0	3.5	3.0	0.03	+0.012 0	+0.046 +0.006
B-003.0-004.5-004.0-E	3.0	4.5	4.0	0.06		
B-003.0-004.5-006.0-E	3.0	4.5	6.0	0.09		
B-003.5-007.8-005.0-E	3.5	7.8	5.0	0.31	+0.015 0	+0.058 +0.010
B-004.0-005.5-004.0-E	4.0	5.5	4.0	0.07	+0.012 0	
B-004.0-005.5-006.0-E	4.0	5.5	6.0	0.11		
B-005.0-007.0-004.8-E	5.0	7.0	4.8	0.15		
B-005.0-007.0-005.0-E	5.0	7.0	5.0	0.16		
B-005.0-007.0-008.0-E	5.0	7.0	8.0	0.25		
B-005.0-007.0-010.0-E	5.0	7.0	10.0	0.31		
B-006.0-008.0-006.0-E	6.0	8.0	6.0	0.22	+0.015 0	
B-006.0-008.0-008.0-E	6.0	8.0	8.0	0.29		
B-006.0-008.0-010.0-E	6.0	8.0	10.0	0.36		
B-008.0-010.0-005.0-E	8.0	10.0	5.0	0.23		
B-008.0-010.0-006.0-E	8.0	10.0	6.0	0.28		
B-008.0-010.0-008.0-E	8.0	10.0	8.0	0.37		
B-008.0-010.0-010.0-E	8.0	10.0	10.0	0.47		
B-008.0-010.0-012.0-E	8.0	10.0	12.0	0.56		
B-008.0-010.0-015.0-E	8.0	10.0	15.0	0.70		
B-008.0-012.0-007.0-E	8.0	12.0	7.0	0.73		
B-008.0-012.0-010.0-E	8.0	12.0	10.0	1.04		
B-010.0-012.0-008.0-E	10.0	12.0	8.0	0.46	+0.018 0	+0.071 +0.013
B-010.0-012.0-009.0-E	10.0	12.0	9.0	0.51		
B-010.0-012.0-010.0-E	10.0	12.0	10.0	0.57		
B-010.0-012.0-012.1-E	10.0	12.0	12.1	0.69		
B-010.0-012.0-015.0-E	10.0	12.0	15.0	0.86		
B-010.0-012.0-020.0-E	10.0	12.0	20.0	1.14		
B-010.0-012.0-025.0-E	10.0	12.0	25.0	1.43		
B-010.0-014.0-008.0-E	10.0	14.0	8.0	1.00		
B-010.0-014.0-010.0-E	10.0	14.0	10.0	1.24		
B-010.0-014.0-012.0-E	10.0	14.0	12.0	1.49		
B-010.0-014.0-028.0-E	10.0	14.0	28.0	3.48		
B-012.0-014.0-008.0-E	12.0	14.0	8.0	0.54	+0.086 +0.016	
B-012.0-014.0-010.0-E	12.0	14.0	10.0	0.67		
B-012.0-014.0-012.0-E	12.0	14.0	12.0	0.81		
B-012.0-014.0-014.0-E	12.0	14.0	14.0	0.94		
B-012.0-014.0-015.0-E	12.0	14.0	15.0	1.01		
B-012.0-014.0-020.0-E	12.0	14.0	20.0	1.35		
B-012.0-014.0-030.0-E	12.0	14.0	30.0	2.02		

The data and specifications in this publication have been carefully compiled and are believed to be accurate and correct. However, it is the responsibility of the user to determine and ensure the suitability of Pacific Bearing® products for a specific application. Pacific Bearing's only obligation will be to repair or replace without charge, any defective components if returned promptly. No liability is assumed beyond such replacement. *Consult www.pacific-bearing.com for the latest technical updates.



Simplicity® Plane Bearings

E - Polymer Series

Linear Motion Systems

E

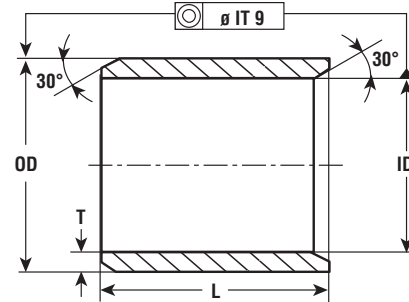

ORDERING INFORMATION

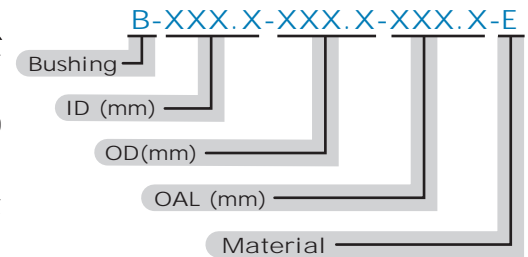

PART NUMBER	DIMENSIONS			WEIGHT [g]	FITTING TOLERANCE	
	ID [mm]	OD [mm]	L [mm]		HOUSING H7 [mm]	ID AFTER FITTING: F10 [mm]
B-012.0-016.0-012.0-E	12.0	16.0	12.0	1.74	+0.018 0	+0.086 +0.016
B-012.0-016.0-020.0-E	12.0	16.0	20.0	2.90		
B-012.0-017.0-020.0-E	12.0	17.0	20.0	3.76		
B-012.0-018.0-010.0-E	12.0	18.0	10.0	2.33		
B-013.0-015.0-010.0-E	13.0	15.0	10.0	0.73		
B-013.0-015.0-020.0-E	13.0	15.0	20.0	1.45		
B-014.0-016.0-010.0-E	14.0	16.0	10.0	0.78		
B-014.0-016.0-015.0-E	14.0	16.0	15.0	1.17		
B-014.0-016.0-020.0-E	14.0	16.0	20.0	1.56		
B-014.0-016.0-025.0-E	14.0	16.0	25.0	1.94		
B-014.0-018.0-014.0-E	14.0	18.0	14.0	2.32		
B-014.0-018.0-020.0-E	14.0	18.0	20.0	3.32		
B-015.0-017.0-010.0-E	15.0	17.0	10.0	0.83		
B-015.0-017.0-015.0-E	15.0	17.0	15.0	1.24		
B-015.0-017.0-020.0-E	15.0	17.0	20.0	1.66		
B-015.0-017.0-025.0-E	15.0	17.0	25.0	2.07		
B-016.0-018.0-007.0-E	16.0	18.0	7.0	0.62		
B-016.0-018.0-010.0-E	16.0	18.0	10.0	0.88		
B-016.0-018.0-012.0-E	16.0	18.0	12.0	1.06		
B-016.0-018.0-015.0-E	16.0	18.0	15.0	1.32		
B-016.0-018.0-020.0-E	16.0	18.0	20.0	1.76		
B-016.0-018.0-025.0-E	16.0	18.0	25.0	2.20		
B-016.0-020.0-020.0-E	16.0	20.0	20.0	3.73		
B-018.0-020.0-015.0-E	18.0	20.0	15.0	1.48		
B-018.0-020.0-020.0-E	18.0	20.0	20.0	1.97		
B-018.0-020.0-025.0-E	18.0	20.0	25.0	2.46		
B-018.0-021.0-020.0-E	18.0	21.0	20.0	3.03		
B-018.0-022.0-018.0-E	18.0	22.0	18.0	3.73		
B-018.0-024.0-018.0-E	18.0	24.0	18.0	5.88		
B-018.0-024.0-028.0-E	18.0	24.0	28.0	9.14		
B-020.0-023.0-010.0-E	20.0	23.0	10.0	1.67		
B-020.0-023.0-015.0-E	20.0	23.0	15.0	2.51		
B-020.0-023.0-020.0-E	20.0	23.0	20.0	3.34		
B-020.0-023.0-025.0-E	20.0	23.0	25.0	4.18		
B-020.0-023.0-030.0-E	20.0	23.0	30.0	5.02		
B-020.0-024.0-020.0-E	20.0	24.0	20.0	4.56		
B-020.0-025.0-015.0-E	20.0	25.0	15.0	4.37		
B-020.0-025.0-020.0-E	20.0	25.0	20.0	5.83		
B-020.0-029.0-030.0-E	20.0	29.0	30.0	17.14		
B-022.0-024.0-010.0-E	22.0	24.0	10.0	1.19		

The data and specifications in this publication have been carefully compiled and are believed to be accurate and correct. However, it is the responsibility of the user to determine and ensure the suitability of Pacific Bearing® products for a specific application. Pacific Bearing's only obligation will be to repair or replace without charge, any defective components if returned promptly. No liability is assumed beyond such replacement. *Consult www.pacific-bearing.com for the latest technical updates.



Simplicity® Plane Bearings

E - Polymer Series

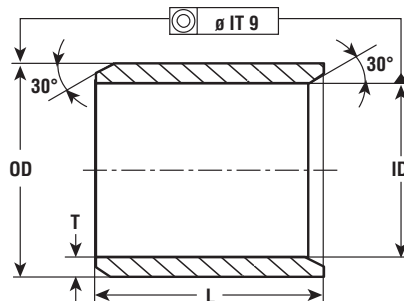

ORDERING INFORMATION

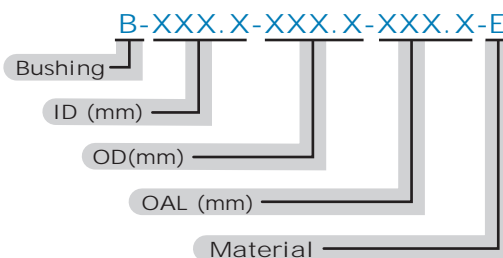

PART NUMBER	DIMENSIONS			WEIGHT [g]	FITTING TOLERANCE	
	ID [mm]	OD [mm]	L [mm]		HOUSING H7 [mm]	ID AFTER FITTING: F10 [mm]
B-022.0-025.0-015.0-E	22.0	25.0	15.0	2.74	+0.021 0	
B-022.0-025.0-020.0-E	22.0	25.0	20.0	3.65		
B-022.0-025.0-025.0-E	22.0	25.0	25.0	4.57		
B-022.0-025.0-030.0-E	22.0	25.0	30.0	5.48		
B-022.0-027.0-020.0-E	22.0	27.0	20.0	6.35		
B-022.0-028.0-020.0-E	22.0	28.0	20.0	7.78		
B-024.0-027.0-015.0-E	24.0	27.0	15.0	2.97		
B-024.0-027.0-020.0-E	24.0	27.0	20.0	3.97		
B-024.0-027.0-030.0-E	24.0	27.0	30.0	5.95		
B-025.0-028.0-015.0-E	25.0	28.0	15.0	3.09		
B-025.0-028.0-020.0-E	25.0	28.0	20.0	4.12		
B-025.0-028.0-025.0-E	25.0	28.0	25.0	5.15		
B-025.0-028.0-030.0-E	25.0	28.0	30.0	6.18		
B-025.0-028.0-035.0-E	25.0	28.0	35.0	7.21		
B-025.0-028.0-050.0-E	25.0	28.0	50.0	10.30		
B-025.0-030.0-018.0-E	25.0	30.0	18.0	6.41		
B-025.0-030.0-020.0-E	25.0	30.0	20.0	7.13		
B-025.0-030.0-022.0-E	25.0	30.0	22.0	7.84		
B-025.0-030.0-023.0-E	25.0	30.0	23.0	8.20		
B-025.0-030.0-025.0-E	25.0	30.0	25.0	8.91		
B-025.0-030.0-030.0-E	25.0	30.0	30.0	10.69		
B-025.0-032.0-025.0-E	25.0	32.0	25.0	12.93	+0.025 0	
B-028.0-031.0-030.0-E	28.0	31.0	30.0	6.88		
B-028.0-032.0-015.0-E	28.0	32.0	15.0	4.67		
B-028.0-032.0-020.0-E	28.0	32.0	20.0	6.22		
B-028.0-032.0-025.0-E	28.0	32.0	25.0	7.78		
B-028.0-032.0-028.0-E	28.0	32.0	28.0	8.71		
B-028.0-032.0-030.0-E	28.0	32.0	30.0	9.33		
B-030.0-032.0-020.0-E	30.0	32.0	20.0	3.21		
B-030.0-034.0-020.0-E	30.0	34.0	20.0	6.64		
B-030.0-034.0-025.0-E	30.0	34.0	25.0	8.29		
B-030.0-034.0-030.0-E	30.0	34.0	30.0	9.95		
B-030.0-034.0-040.0-E	30.0	34.0	40.0	13.27		
B-030.0-035.0-014.0-E	30.0	35.0	14.0	5.90		
B-030.0-035.0-030.0-E	30.0	35.0	30.0	12.64		
B-030.0-037.0-040.0-E	30.0	37.0	40.0	24.31		
B-032.0-036.0-020.0-E	32.0	36.0	20.0	7.05	+0.125 +0.025	
B-032.0-036.0-025.0-E	32.0	36.0	25.0	8.81		
B-032.0-036.0-030.0-E	32.0	36.0	30.0	10.57		
B-032.0-036.0-040.0-E	32.0	36.0	40.0	14.10		

The data and specifications in this publication have been carefully compiled and are believed to be accurate and correct. However, it is the responsibility of the user to determine and ensure the suitability of Pacific Bearing® products for a specific application. Pacific Bearing's only obligation will be to repair or replace without charge, any defective components if returned promptly. No liability is assumed beyond such replacement. *Consult www.pacific-bearing.com for the latest technical updates.



Simplicity® Plane Bearings

E - Polymer Series

E

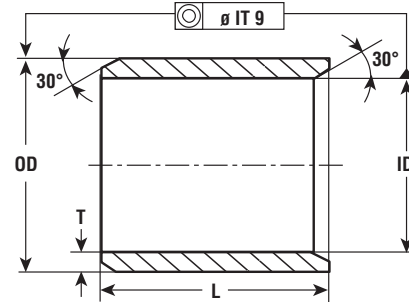

ORDERING INFORMATION

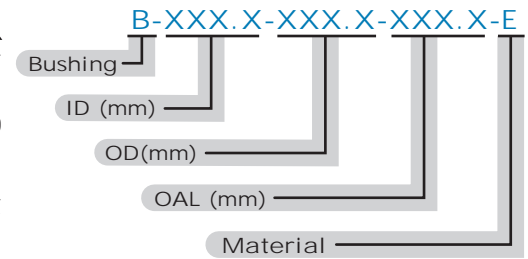

PART NUMBER	DIMENSION			WEIGHT [g]	FITTING TOLERANCE	
	ID [mm]	OD [mm]	L [mm]		HOUSING H7 [mm]	ID AFTER FITTING: F10 [mm]
B-032.0-036.0-050.0-E	32.0	36.0	50.0	17.62	+0.025 0	
B-032.0-036.0-054.0-E	32.0	36.0	54.0	19.03		
B-032.0-038.0-042.0-E	32.0	38.0	42.0	22.86		
B-032.0-040.0-025.0-E	32.0	40.0	25.0	18.66		
B-035.0-039.0-010.0-E	35.0	39.0	10.0	3.84		
B-035.0-039.0-020.0-E	35.0	39.0	20.0	7.67		
B-035.0-039.0-025.0-E	35.0	39.0	25.0	9.59		
B-035.0-039.0-030.0-E	35.0	39.0	30.0	11.51		
B-035.0-039.0-040.0-E	35.0	39.0	40.0	15.34		
B-035.0-039.0-050.0-E	35.0	39.0	50.0	19.18		
B-036.0-040.0-025.0-E	36.0	40.0	25.0	9.85		
B-036.0-040.0-040.0-E	36.0	40.0	40.0	15.76		
B-036.0-040.0-050.0-E	36.0	40.0	50.0	19.70		
B-036.0-042.0-030.0-E	36.0	42.0	30.0	18.19		
B-038.0-042.0-025.0-E	38.0	42.0	25.0	10.37		
B-040.0-042.0-025.0-E	40.0	42.0	25.0	5.31		
B-040.0-044.0-020.0-E	40.0	44.0	20.0	8.71		
B-040.0-044.0-025.0-E	40.0	44.0	25.0	10.89		
B-040.0-044.0-030.0-E	40.0	44.0	30.0	13.06		
B-040.0-044.0-040.0-E	40.0	44.0	40.0	17.42		
B-040.0-044.0-050.0-E	40.0	44.0	50.0	21.77		
B-040.0-045.0-040.0-E	40.0	45.0	40.0	22.03		
B-043.0-046.0-030.0-E	43.0	46.0	30.0	10.38		
B-045.0-050.0-020.0-E	45.0	50.0	20.0	12.31		
B-045.0-050.0-025.0-E	45.0	50.0	25.0	15.39		
B-045.0-050.0-030.0-E	45.0	50.0	30.0	18.47		
B-045.0-050.0-040.0-E	45.0	50.0	40.0	24.62		
B-045.0-050.0-045.0-E	45.0	50.0	45.0	27.70		
B-045.0-050.0-050.0-E	45.0	50.0	50.0	30.78		
B-045.0-050.0-060.0-E	45.0	50.0	60.0	36.93		
B-050.0-055.0-020.0-E	50.0	55.0	20.0	13.61		
B-050.0-055.0-025.0-E	50.0	55.0	25.0	17.01		
B-050.0-055.0-030.0-E	50.0	55.0	30.0	20.41		
B-050.0-055.0-040.0-E	50.0	55.0	40.0	27.21		
B-050.0-055.0-050.0-E	50.0	55.0	50.0	34.02		
B-050.0-055.0-060.0-E	50.0	55.0	60.0	40.82		
B-050.0-055.0-070.0-E	50.0	55.0	70.0	47.62		
B-050.0-058.0-040.0-E	50.0	58.0	40.0	44.79		
B-055.0-060.0-040.0-E	55.0	60.0	40.0	29.81		
B-055.0-060.0-060.0-E	55.0	60.0	60.0	44.71		
					+0.125 +0.025	
					+0.030 0	
						+0.150 +0.030

The data and specifications in this publication have been carefully compiled and are believed to be accurate and correct. However, it is the responsibility of the user to determine and ensure the suitability of Pacific Bearing® products for a specific application. Pacific Bearing's only obligation will be to repair or replace without charge, any defective components if returned promptly. No liability is assumed beyond such replacement. *Consult www.pacific-bearing.com for the latest technical updates.



Simplicity® Plane Bearings

E - Polymer Series

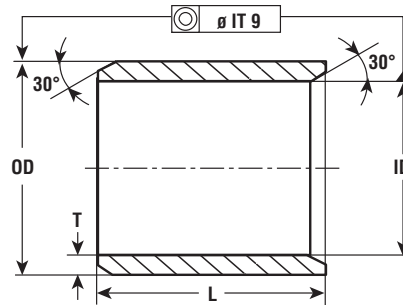
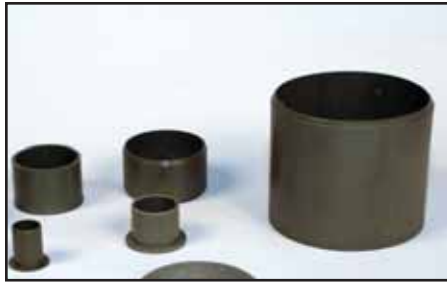

ORDERING INFORMATION

B-XXX.X-XXX.X-XXX.X-E

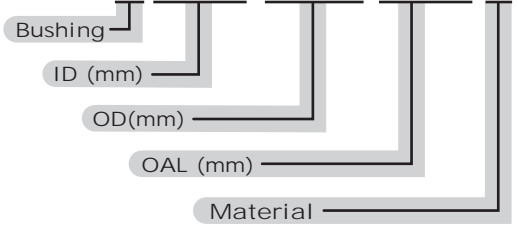

PART NUMBER	DIMENSION			WEIGHT [g]	FITTING TOLERANCE	
	ID [mm]	OD [mm]	L [mm]		HOUSING H7 [mm]	ID AFTER FITTING: F10 [mm]
B-055.0-065.0-040.0-E	55.0	65.0	40.0	62.20	+0.030 0	+0.150 +0.030
B-060.0-065.0-030.0-E	60.0	65.0	30.0	24.30		
B-060.0-065.0-040.0-E	60.0	65.0	40.0	32.40		
B-060.0-065.0-060.0-E	60.0	65.0	60.0	48.60		
B-060.0-065.0-070.0-E	60.0	65.0	70.0	56.70		
B-064.0-068.0-052.5-E	64.0	68.0	52.5	35.92		
B-065.0-070.0-040.0-E	65.0	70.0	40.0	34.99		
B-065.0-070.0-060.0-E	65.0	70.0	60.0	52.48		
B-068.0-072.0-010.0-E	68.0	72.0	10.0	7.26		
B-070.0-075.0-040.0-E	70.0	75.0	40.0	37.58		
B-070.0-075.0-060.0-E	70.0	75.0	60.0	56.37		
B-070.0-075.0-070.0-E	70.0	75.0	70.0	65.77		
B-070.0-075.0-080.0-E	70.0	75.0	80.0	75.16		
B-075.0-080.0-025.0-E	75.0	80.0	25.0	25.11		
B-075.0-080.0-032.0-E	75.0	80.0	32.0	32.14		
B-075.0-080.0-040.0-E	75.0	80.0	40.0	40.17		
B-080.0-085.0-040.0-E	80.0	85.0	40.0	42.76		
B-080.0-085.0-050.0-E	80.0	85.0	50.0	53.46		
B-080.0-085.0-060.0-E	80.0	85.0	60.0	64.15		
B-080.0-085.0-080.0-E	80.0	85.0	80.0	85.53		
B-080.0-085.0-100.0-E	80.0	85.0	100.0	106.91		
B-085.0-090.0-040.0-E	85.0	90.0	40.0	45.36		
B-085.0-090.0-080.0-E	85.0	90.0	80.0	90.71		
B-089.0-094.0-020.0-E	89.0	94.0	20.0	23.72		
B-090.0-095.0-050.0-E	90.0	95.0	50.0	59.94		
B-090.0-095.0-090.0-E	90.0	95.0	90.0	107.88		
B-100.0-105.0-050.0-E	100.0	105.0	50.0	66.42		
B-100.0-105.0-095.0-E	100.0	105.0	95.0	126.19		
B-100.0-105.0-100.0-E	100.0	105.0	100.0	132.83		
B-120.0-125.0-050.0-E	120.0	125.0	50.0	79.37		
B-120.0-125.0-150.0-E	120.0	125.0	150.0	238.12		
B-125.0-130.0-030.0-E	125.0	130.0	30.0	49.57		
B-125.0-130.0-060.0-E	125.0	130.0	60.0	99.14		
B-130.0-135.0-050.0-E	130.0	135.0	50.0	85.85		
B-130.0-135.0-060.0-E	130.0	135.0	60.0	103.02		
B-150.0-155.0-060.0-E	150.0	155.0	60.0	118.58		
B-195.0-200.0-014.0-E	195.0	200.0	14.0	35.83	+0.046 0	+0.235 +0.050

The data and specifications in this publication have been carefully compiled and are believed to be accurate and correct. However, it is the responsibility of the user to determine and ensure the suitability of Pacific Bearing® products for a specific application. Pacific Bearing's only obligation will be to repair or replace without charge, any defective components if returned promptly. No liability is assumed beyond such replacement. *Consult www.pacific-bearing.com for the latest technical updates.



Simplicity® Plane Bearings

Flanged E - Polymer Series

Linear Motion Systems

Flanged E

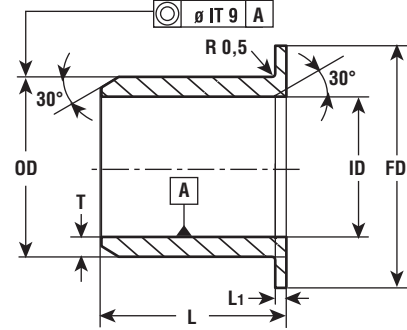

ORDERING INFORMATION

F-XXX-XXX.X-XXX.X-X.XX-XXX.X-E

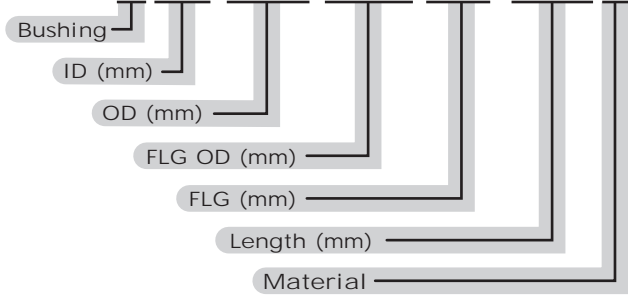

PART NUMBER	DIMENSION					WEIGHT [g]	FITTING TOLERANCE			
	ID [mm]	OD [mm]	FD [mm]	L1 [mm]	L [mm]		HOUSING H7 [mm]	ID AFTER FITTING: F10 [mm]		
F-003-004.5-007.0-0.75-003.0-E	3.0	4.5	7.0	0.75	3.0	0.07	+0.012 0	+0.046 +0.006		
F-003-004.5-007.0-0.75-005.0-E	3.0	4.5	7.0	0.75	5.0	0.10				
F-004-005.5-009.0-0.75-003.0-E	4.0	5.5	9.0	0.75	3.0	0.10				
F-004-005.5-009.0-0.75-004.0-E	4.0	5.5	9.0	0.75	4.0	0.12	+0.015 0	+0.058 +0.010		
F-004-005.5-009.0-0.75-006.0-E	4.0	5.5	9.0	0.75	6.0	0.16				
F-005-007.0-010.0-1.00-004.0-E	5.0	7.0	10.0	1.00	4.0	0.19				
F-005-007.0-010.0-1.00-006.0-E	5.0	7.0	10.0	1.00	6.0	0.25				
F-006-008.0-012.0-1.00-004.0-E	6.0	8.0	12.0	1.00	4.0	0.25				
F-006-008.0-012.0-2.50-005.5-E	6.0	8.0	12.0	2.50	5.5	0.46				
F-006-008.0-012.0-1.00-006.0-E	6.0	8.0	12.0	1.00	6.0	0.32				
F-006-008.0-012.0-1.00-008.0-E	6.0	8.0	12.0	1.00	8.0	0.39				
F-006-008.0-012.0-1.00-010.0-E	6.0	8.0	12.0	1.00	10.0	0.47	+0.021 0	+0.071 +0.013		
F-006-019.5-025.0-2.00-005.0-E	6.0	19.5	25.0	2.00	5.0	2.86				
F-008-010.0-015.0-1.00-004.5-E	8.0	10.0	15.0	1.00	4.5	0.37	+0.015 0		+0.086 +0.016	
F-008-010.0-015.0-1.00-005.5-E	8.0	10.0	15.0	1.00	5.5	0.42				
F-008-010.0-014.0-1.00-008.0-E	8.0	10.0	14.0	1.00	8.0	0.50				
F-008-010.0-015.0-1.00-009.5-E	8.0	10.0	15.0	1.00	9.5	0.61				
F-008-010.0-014.0-1.00-010.0-E	8.0	10.0	14.0	1.00	10.0	0.59				
F-008-010.0-014.0-2.00-012.0-E	8.0	10.0	14.0	2.00	12.0	0.81				
F-008-012.0-018.0-2.00-008.0-E	8.0	12.0	18.0	2.00	8.0	1.30	+0.018 0			+0.086 +0.016
F-008-012.0-021.0-2.00-008.0-E	8.0	12.0	21.0	2.00	8.0	1.60				
F-008-012.0-016.0-2.00-010.0-E	8.0	12.0	16.0	2.00	10.0	1.33				
F-010-012.0-016.0-1.00-006.0-E	10.0	12.0	16.0	1.00	6.0	0.49				
F-010-012.0-018.0-1.00-007.0-E	10.0	12.0	18.0	1.00	7.0	0.63				
F-010-012.0-022.0-1.00-007.0-E	10.0	12.0	22.0	1.00	7.0	0.84				
F-010-012.0-016.0-2.00-012.0-E	10.0	12.0	16.0	2.00	12.0	0.97				
F-010-012.0-019.0-2.00-016.0-E	10.0	12.0	19.0	2.00	16.0	1.47				
F-010-012.0-018.0-1.00-017.0-E	10.0	12.0	18.0	1.00	17.0	1.20				
F-010-014.0-018.0-2.00-010.0-E	10.0	14.0	18.0	2.00	10.0	1.58				
F-010-016.0-020.5-2.00-011.0-E	10.0	16.0	20.5	2.00	11.0	2.65				
F-010-017.0-031.0-2.00-025.0-E	10.0	17.0	31.0	2.00	25.0	7.86				
F-011-014.0-017.0-1.50-006.5-E	11.0	14.0	17.0	1.50	6.5	0.81	+0.018 0	+0.086 +0.016		
F-012-014.0-018.0-1.00-010.0-E	12.0	14.0	18.0	1.00	10.0	0.84				
F-012-014.0-018.0-1.00-012.0-E	12.0	14.0	18.0	1.00	12.0	0.97				
F-012-014.0-018.0-2.00-012.0-E	12.0	14.0	18.0	2.00	12.0	1.14				
F-012-014.0-017.0-0.50-004.0-E	12.0	14.0	17.0	0.50	4.0	1.68				

The data and specifications in this publication have been carefully compiled and are believed to be accurate and correct. However, it is the responsibility of the user to determine and ensure the suitability of Pacific Bearing® products for a specific application. Pacific Bearing's only obligation will be to repair or replace without charge, any defective components if returned promptly. No liability is assumed beyond such replacement. *Consult www.pacific-bearing.com for the latest technical updates.



Simplicity® Plane Bearings

Flanged E - Polymer Series

Linear Motion Systems

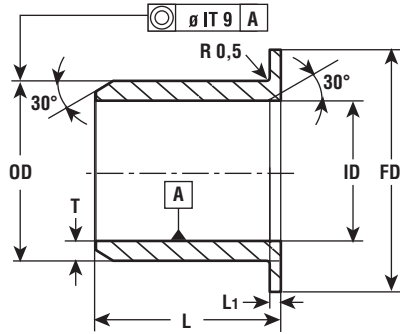

ORDERING INFORMATION

F-XXX-XXX.X-XXX.X-X.XX-XXX.X-E

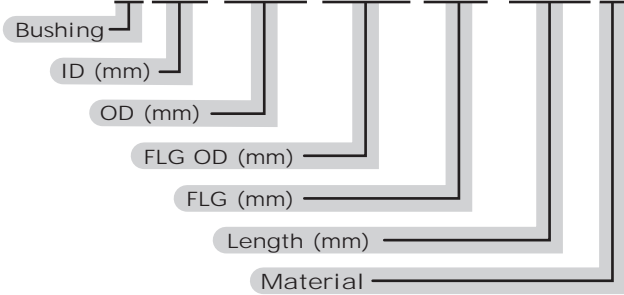

Flanged E

PART NUMBER	DIMENSION					WEIGHT [g]	FITTING TOLERANCE	
	ID [mm]	OD [mm]	FD [mm]	L1 [mm]	L [mm]		HOUSING H7 [mm]	ID AFTER FITTING: F10 [mm]
F-012-015.0-022.0-1.00-006.0-E	12.0	15.0	22.0	1.00	6.0	0.97	+0.018 0	+0.086 +0.016
F-012-016.0-020.0-2.00-008.0-E	12.0	16.0	20.0	2.00	8.0	1.53		
F-012-016.0-020.0-2.00-010.0-E	12.0	16.0	20.0	2.00	10.0	1.82		
F-012-016.0-020.0-2.00-012.0-E	12.0	16.0	20.0	2.00	12.0	2.11		
F-012-016.0-020.0-2.00-015.0-E	12.0	16.0	20.0	2.00	15.0	2.55		
F-012-016.0-020.0-2.00-019.0-E	12.0	16.0	20.0	2.00	19.0	3.13		
F-014-016.0-020.0-1.00-009.0-E	14.0	16.0	20.0	1.00	9.0	0.89		
F-014-016.0-022.0-1.00-012.0-E	14.0	16.0	22.0	1.00	12.0	1.23		
F-014-016.0-020.0-2.00-014.0-E	14.0	16.0	20.0	2.00	14.0	1.46		
F-014-016.0-020.0-2.00-015.0-E	14.0	16.0	20.0	2.00	15.0	1.54		
F-014-018.0-022.0-2.00-009.5-E	14.0	18.0	22.0	2.00	9.5	1.99		
F-014-018.0-022.0-2.00-014.0-E	14.0	18.0	22.0	2.00	14.0	2.74		
F-015-017.0-023.0-1.00-017.0-E	15.0	17.0	23.0	1.00	17.0	1.72		
F-016-018.0-024.0-1.00-012.0-E	16.0	18.0	24.0	1.00	12.0	1.38		
F-016-018.0-024.0-1.00-017.0-E	16.0	18.0	24.0	1.00	17.0	1.82		
F-016-018.0-032.0-1.50-021.0-E	16.0	18.0	32.0	1.50	21.0	3.21		
F-016-018.0-022.0-2.00-022.0-E	16.0	18.0	22.0	2.00	22.0	2.35		
F-016-020.0-028.0-2.00-015.0-E	16.0	20.0	28.0	2.00	15.0	3.79		
F-016-020.0-024.0-2.00-016.0-E	16.0	20.0	24.0	2.00	16.0	3.44		
F-016-020.0-024.0-2.00-022.0-E	16.0	20.0	24.0	2.00	22.0	4.56		
F-017-021.0-025.0-2.00-022.0-E	17.0	21.0	25.0	2.00	22.0	4.81		
F-018-020.0-026.0-1.00-012.0-E	18.0	20.0	26.0	1.00	12.0	1.54		
F-018-020.0-026.0-1.00-017.0-E	18.0	20.0	26.0	1.00	17.0	2.03		
F-018-020.0-024.0-2.00-022.0-E	18.0	20.0	24.0	2.00	22.0	2.62		
F-018-020.0-026.0-1.00-022.0-E	18.0	20.0	26.0	1.00	22.0	2.52		
F-018-022.0-026.0-2.00-006.8-E	18.0	22.0	26.0	2.00	6.8	1.91		
F-018-022.0-026.0-2.00-018.0-E	18.0	22.0	26.0	2.00	18.0	4.23		
F-019-021.0-024.0-0.50-015.0-E	19.0	21.0	24.0	0.50	15.0	1.64		
F-020-023.0-030.0-1.50-012.0-E	20.0	23.0	30.0	1.50	12.0	2.73		
F-020-023.0-030.0-2.00-012.0-E	20.0	23.0	30.0	2.00	12.0	2.97		
F-020-023.0-030.0-2.00-015.0-E	20.0	23.0	30.0	2.00	15.0	3.47		
F-020-023.0-030.0-2.00-020.0-E	20.0	23.0	30.0	2.00	20.0	4.30		
F-020-023.0-030.0-2.00-022.0-E	20.0	23.0	30.0	2.00	22.0	4.64		
F-020-023.0-030.0-2.00-025.0-E	20.0	23.0	30.0	2.00	25.0	5.14		
F-020-023.0-035.0-2.00-025.0-E	20.0	23.0	35.0	2.00	25.0	5.98		
F-020-024.0-030.0-2.00-015.0-E	20.0	24.0	30.0	2.00	15.0	4.26		
F-020-024.0-024.6-3.00-020.0-E	20.0	24.0	24.6	3.00	20.0	4.67		

The data and specifications in this publication have been carefully compiled and are believed to be accurate and correct. However, it is the responsibility of the user to determine and ensure the suitability of Pacific Bearing® products for a specific application. Pacific Bearing's only obligation will be to repair or replace without charge, any defective components if returned promptly. No liability is assumed beyond such replacement. *Consult www.pacific-bearing.com for the latest technical updates.



Simplicity® Plane Bearings

Flanged E - Polymer Series

Linear Motion Systems

Flanged E

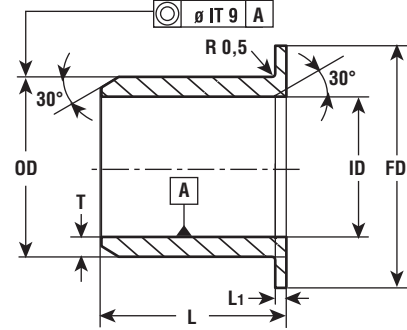

ORDERING INFORMATION

F-XXX-XXX.X-XXX.X-X.XX-XXX.X-E

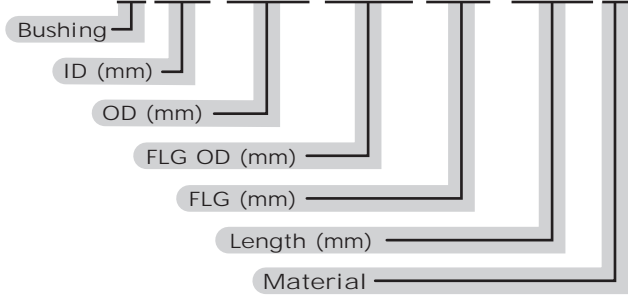

PART NUMBER	DIMENSION					WEIGHT	FITTING TOLERANCE	
	ID [mm]	OD [mm]	FD [mm]	L1 [mm]	L [mm]	[g]	HOUSING H7 [mm]	ID AFTER FITTING: F10 [mm]
F-020-024.0-030.0-2.00-020.0-E	20.0	24.0	30.0	2.00	20.0	5.40	+0.021 0	+0.104 +0.020
F-020-025.0-030.0-2.00-015.0-E	20.0	25.0	30.0	2.00	15.0	5.09		
F-022-025.0-033.0-1.50-023.5-E	22.0	25.0	33.0	1.50	23.5	5.20		
F-022-028.0-033.0-2.00-020.0-E	22.0	28.0	33.0	2.00	20.0	8.57		
F-024-027.0-032.5-2.00-022.0-E	24.0	27.0	32.5	2.00	22.0	5.21		
F-025-028.0-035.0-2.00-022.0-E	25.0	28.0	35.0	2.00	22.0	5.68		
F-025-028.0-035.0-2.00-025.0-E	25.0	28.0	35.0	2.00	25.0	6.29		
F-025-028.0-035.0-2.00-032.0-E	25.0	28.0	35.0	2.00	32.0	7.74		
F-025-030.0-035.0-2.50-020.0-E	25.0	30.0	35.0	2.50	20.0	8.18		
F-025-030.0-033.0-2.00-023.0-E	25.0	30.0	33.0	2.00	23.0	8.69		
F-025-030.0-035.0-2.50-025.0-E	25.0	30.0	35.0	2.50	25.0	9.96		
F-025-030.0-033.0-2.00-027.0-E	25.0	30.0	33.0	2.00	27.0	10.11		
F-025-030.0-033.0-2.00-032.0-E	25.0	30.0	33.0	2.00	32.0	11.89		
F-025-032.0-038.0-2.50-018.5-E	25.0	32.0	38.0	2.50	18.5	10.93	+0.025 0	
F-025-034.0-040.0-3.50-040.0-E	25.0	34.0	40.0	3.50	40.0	29.54	+0.021 0	
F-026-029.0-031.0-2.00-007.0-E	26.0	29.0	31.0	2.00	7.0	1.81	+0.025 0	+0.125 +0.025
F-028-032.0-038.0-2.00-017.0-E	28.0	32.0	38.0	2.00	17.0	6.38		
F-028-032.0-038.0-2.00-028.0-E	28.0	32.0	38.0	2.00	28.0	9.80		
F-030-034.0-045.0-2.00-018.0-E	30.0	34.0	45.0	2.00	18.0	8.22		
F-030-034.0-045.0-2.00-022.0-E	30.0	34.0	45.0	2.00	22.0	9.55		
F-030-034.0-045.0-2.00-032.0-E	30.0	34.0	45.0	2.00	32.0	12.87		
F-030-035.0-038.0-2.00-015.5-E	30.0	35.0	38.0	2.00	15.5	7.10		
F-030-035.0-042.0-2.50-030.0-E	30.0	35.0	42.0	2.50	30.0	14.38		
F-030-036.0-050.0-3.00-020.0-E	30.0	36.0	50.0	3.00	20.0	14.94		
F-030-038.0-042.0-5.00-025.0-E	30.0	38.0	42.0	5.00	25.0	19.70		
F-032-036.0-036.8-3.00-025.0-E	32.0	36.0	36.8	3.00	25.0	9.04		
F-032-036.0-042.0-2.00-032.0-E	32.0	36.0	42.0	2.00	32.0	12.49		
F-035-039.0-048.0-2.00-010.0-E	35.0	39.0	48.0	2.00	10.0	5.87		
F-035-039.0-050.0-2.00-012.0-E	35.0	39.0	50.0	2.00	12.0	7.14		
F-035-039.0-048.0-2.00-013.0-E	35.0	39.0	48.0	2.00	13.0	7.02		
F-035-039.0-047.0-2.00-016.0-E	35.0	39.0	47.0	2.00	16.0	7.92		
F-035-039.0-050.0-2.00-022.0-E	35.0	39.0	50.0	2.00	22.0	10.98		
F-035-039.0-050.0-2.00-032.0-E	35.0	39.0	50.0	2.00	32.0	14.81		
F-035-039.0-050.0-2.00-040.0-E	35.0	39.0	50.0	2.00	40.0	17.88		
F-035-039.0-050.0-2.00-050.0-E	35.0	39.0	50.0	2.00	50.0	21.72		
F-040-044.0-055.0-2.00-025.0-E	40.0	44.0	55.0	2.00	25.0	13.71		

The data and specifications in this publication have been carefully compiled and are believed to be accurate and correct. However, it is the responsibility of the user to determine and ensure the suitability of Pacific Bearing® products for a specific application. Pacific Bearing's only obligation will be to repair or replace without charge, any defective components if returned promptly. No liability is assumed beyond such replacement. *Consult www.pacific-bearing.com for the latest technical updates.



Simplicity® Plane Bearings

Flanged E - Polymer Series

Linear Motion Systems

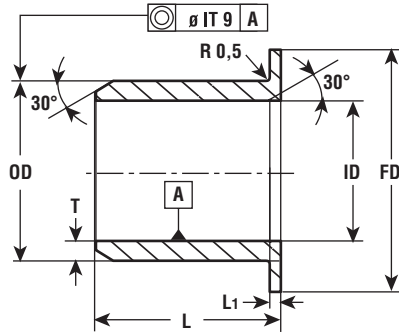

ORDERING INFORMATION

F-XXX-XXX.X-XXX.X-X.XX-XXX.X-E

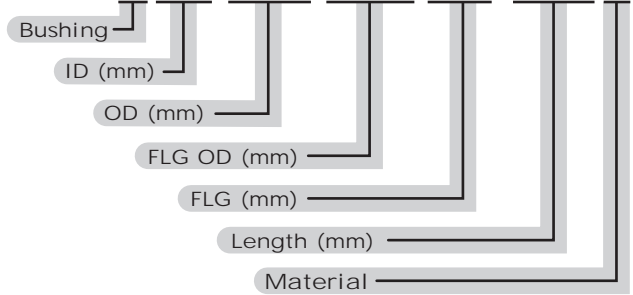

Flanged E

PART NUMBER	DIMENSION					WEIGHT [g]	FITTING TOLERANCE	
	ID [mm]	OD [mm]	FD [mm]	L1 [mm]	L [mm]		HOUSING H7 [mm]	ID AFTER FITTING: F10 [mm]
F-040-044.0-052.0-2.50-040.0-E	40.0	44.0	52.0	2.50	40.0	19.91	+0.025 0	+0.125 +0.025
F-040-044.0-055.0-2.00-040.0-E	40.0	44.0	55.0	2.00	40.0	20.24		
F-040-045.0-052.0-2.50-040.0-E	40.0	45.0	52.0	2.50	40.0	24.23		
F-045-050.0-060.0-2.50-032.0-E	45.0	50.0	60.0	2.50	32.0	23.26		
F-045-050.0-060.0-2.50-038.0-E	45.0	50.0	60.0	2.50	38.0	26.95		
F-045-050.0-062.0-2.00-038.0-E	45.0	50.0	62.0	2.00	38.0	26.87		
F-045-050.0-060.0-2.50-045.0-E	45.0	50.0	60.0	2.50	45.0	31.26		
F-045-050.0-060.0-2.50-050.0-E	45.0	50.0	60.0	2.50	50.0	34.34		
F-050-055.0-063.0-2.00-010.0-E	50.0	55.0	63.0	2.00	10.0	9.25		
F-050-055.0-065.0-2.00-020.0-E	50.0	55.0	65.0	2.00	20.0	16.72		
F-050-055.0-065.0-2.50-020.5-E	50.0	55.0	65.0	2.50	20.5	17.83		
F-050-055.0-065.0-2.50-024.0-E	50.0	55.0	65.0	2.50	24.0	20.22		
F-050-055.0-065.0-2.50-032.0-E	50.0	55.0	65.0	2.50	32.0	25.66		
F-050-055.0-065.0-2.50-050.0-E	50.0	55.0	65.0	2.50	50.0	37.91		
F-050-056.0-070.0-3.00-025.0-E	50.0	56.0	70.0	3.00	25.0	27.46		
F-055-060.0-070.0-2.50-040.0-E	55.0	60.0	70.0	2.50	40.0	34.02		
F-055-060.0-070.0-2.50-060.0-E	55.0	60.0	70.0	2.50	60.0	48.92		
F-060-064.0-075.0-2.50-060.0-E	60.0	64.0	75.0	2.50	60.0	43.52		
F-060-065.0-075.0-2.50-040.0-E	60.0	65.0	75.0	2.50	40.0	36.93		
F-060-065.0-075.0-2.50-060.0-E	60.0	65.0	75.0	2.50	60.0	53.13		
F-065-070.0-080.0-2.50-040.0-E	65.0	70.0	80.0	2.50	40.0	39.85		
F-065-070.0-080.0-2.50-060.0-E	65.0	70.0	80.0	2.50	60.0	57.34		
F-070-075.0-085.0-2.50-040.0-E	70.0	75.0	85.0	2.50	40.0	42.76		
F-070-075.0-085.0-2.50-070.0-E	70.0	75.0	85.0	2.50	70.0	70.95		
F-075-080.0-090.0-2.50-040.0-E	75.0	80.0	90.0	2.50	40.0	45.68		
F-075-080.0-090.0-2.50-070.0-E	75.0	80.0	90.0	2.50	70.0	75.81		
F-080-085.0-095.0-2.50-040.0-E	80.0	85.0	95.0	2.50	40.0	48.60		
F-080-085.0-095.0-2.50-080.0-E	80.0	85.0	95.0	2.50	80.0	91.36		
F-090-095.0-110.0-2.50-050.0-E	90.0	95.0	110.0	2.50	50.0	69.90		
F-090-095.0-110.0-2.50-090.0-E	90.0	95.0	110.0	2.50	90.0	117.85		
F-100-105.0-120.0-2.50-050.0-E	100.0	105.0	120.0	2.50	50.0	77.35		
F-100-105.0-120.0-2.50-090.0-E	100.0	105.0	120.0	2.50	90.0	130.48		
F-110-115.0-130.0-2.50-090.0-E	110.0	115.0	130.0	2.50	90.0	143.12		
F-140-145.0-160.0-2.50-040.0-E	140.0	145.0	160.0	2.50	40.0	88.69		
F-140-145.0-165.0-2.50-060.0-E	140.0	145.0	165.0	2.50	60.0	130.89		
							+0.030 0	+0.150 +0.030
							+0.035 0	+0.176 +0.036
							+0.040 0	+0.203 +0.043

The data and specifications in this publication have been carefully compiled and are believed to be accurate and correct. However, it is the responsibility of the user to determine and ensure the suitability of Pacific Bearing® products for a specific application. Pacific Bearing's only obligation will be to repair or replace without charge, any defective components if returned promptly. No liability is assumed beyond such replacement. *Consult www.pacific-bearing.com for the latest technical updates.



THRUST WASHERS WITHOUT MOUNTING HOLE

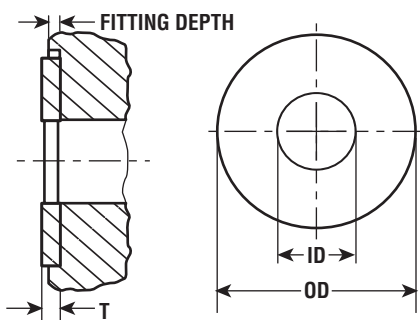

PART NUMBER	ID [mm]	OD [mm]	T [mm]	FITTING DEPTH [mm]	WEIGHT [g]
T-010.0-020.0-01.5-E	10.0	20.0	1.5	0.95 - 1.20	0.58
T-010.0-022.0-01.5-E	10.0	22.0	1.5	0.95 - 1.20	0.75
T-011.2-015.0-01.5-E	11.2	15.0	1.5	0.95 - 1.20	0.19
T-012.0-020.0-02.0-E	12.0	20.0	2.0	1.25 - 1.60	0.66
T-015.0-030.0-02.0-E	15.0	30.0	2.0	1.25 - 1.60	1.75
T-016.0-032.0-02.5-E	16.0	32.0	2.5	1.60 - 2.00	2.49
T-018.5-031.8-01.5-E	18.5	31.8	1.5	0.95 - 1.20	1.30
T-026.0-044.0-01.5-E	26.0	44.0	1.5	0.95 - 1.20	2.45
T-028.5-042.0-01.5-E	28.5	42.0	1.5	0.95 - 1.20	1.85
T-037.0-052.0-02.0-E	37.0	52.0	2.0	1.25 - 1.60	3.46
T-038.0-062.0-01.5-E	38.0	62.0	1.5	0.95 - 1.20	4.67
T-068.0-080.0-02.0-E	68.0	80.0	2.0	1.25 - 1.60	4.60
T-075.0-093.0-01.0-E	75.0	93.0	1.0	0.60 - 0.80	3.92
T-080.5-093.0-01.5-E	80.5	93.0	1.5	0.95 - 1.20	4.22
T-080.5-114.0-01.5-E	80.5	114.0	1.5	0.95 - 1.20	12.67
T-104.0-126.0-01.5-E	104.0	126.0	1.5	0.95 - 1.20	9.84
T-120.0-140.0-02.5-E	120.0	140.0	2.5	1.60 - 2.00	16.85
T-140.0-160.0-03.0-E	140.0	160.0	3.0	1.90 - 2.40	23.33
T-141.0-164.0-03.0-E	141.0	164.0	3.0	1.90 - 2.40	27.27
T-160.0-190.0-02.0-E	160.0	190.0	2.0	1.25 - 1.60	27.21
T-160.0-200.0-02.0-E	160.0	200.0	2.0	1.25 - 1.60	37.32

ORDERING INFORMATION

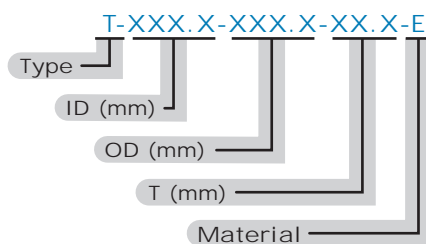

THRUST WASHERS WITH MOUNTING HOLE

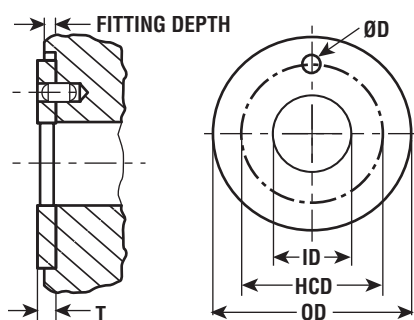

ORDERING INFORMATION

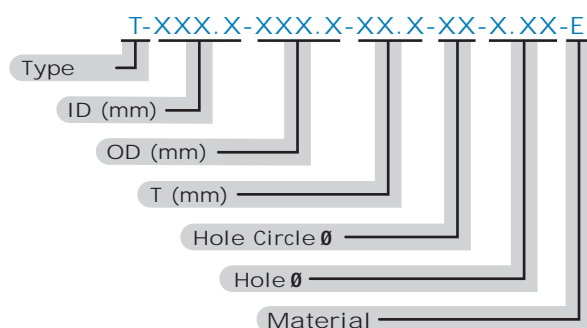

PART NUMBER	ID [mm]	OD [mm]	T [mm]	FITTING DEPTH [mm]	HOLE CIRCLE D [mm]	PIN HOLE D [mm]	WEIGHT [g]
T-024.0-001.5-18.0-02-1.75-E	12.0	24.0	1.5	0.95 - 1.20	18.0	1.75	1.75
T-026.0-001.5-20.0-02-2.25-E	14.0	26.0	1.5	0.95 - 1.20	20.0	2.25	2.25
T-030.0-001.5-22.0-02-2.25-E	16.0	30.0	1.5	0.95 - 1.20	22.0	2.25	1.24
T-032.0-001.5-25.0-02-2.25-E	18.0	32.0	1.5	0.95 - 1.20	25.0	2.25	1.35
T-036.0-001.5-28.0-03-3.25-E	20.0	36.0	1.5	0.95 - 1.20	28.0	3.25	1.73
T-038.0-001.5-30.0-03-3.25-E	22.0	38.0	1.5	0.95 - 1.20	30.0	3.25	1.85

The data and specifications in this publication have been carefully compiled and are believed to be accurate and correct. However, it is the responsibility of the user to determine and ensure the suitability of Pacific Bearing® products for a specific application. Pacific Bearing's only obligation will be to repair or replace without charge, any defective components if returned promptly. No liability is assumed beyond such replacement. *Consult www.pacific-bearing.com for the latest technical updates.



Simplicity® Plane Bearings

With Seals E - Polymer Series

Linear Motion Systems

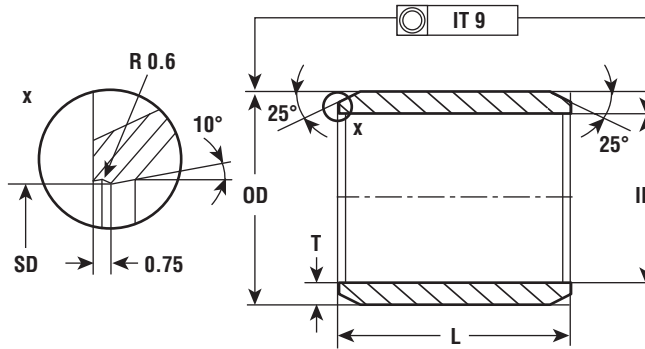

ORDERING INFORMATION

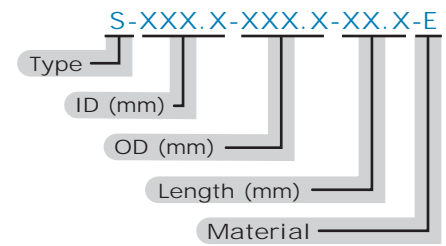

Seals E

PART NUMBER	DIMENSION			WEIGHT [g]	FITTING TOLERANCE	
	ID [mm]	OD [mm]	L [mm]		HOUSING H7 [mm]	ID AFTER FITTING: F10 [mm]
S-040.0-044.0-025.0-E	40.0	44.0	25.0	10.9	+0.025 0	+0.125 +0.025
S-040.0-044.0-040.0-E	40.0	44.0	40.0	17.4		
S-045.0-050.0-030.0-E	45.0	50.0	30.0	18.5		
S-045.0-050.0-050.0-E	45.0	50.0	50.0	30.8		
S-045.0-050.0-060.0-E	45.0	50.0	60.0	36.9		
S-050.0-055.0-040.0-E	50.0	55.0	40.0	27.2	+0.030 0	
S-050.0-055.0-050.0-E	50.0	55.0	50.0	34.0		
S-050.0-055.0-060.0-E	50.0	55.0	60.0	40.8		
S-050.0-058.0-040.0-E	50.0	58.0	40.0	44.8		
S-050.0-066.0-060.0-E	50.0	66.0	60.0	144.3		
S-060.0-065.0-050.0-E	60.0	65.0	50.0	40.5	+0.035 0	+0.150 +0.030
S-060.0-065.0-060.0-E	60.0	65.0	60.0	48.6		
S-070.0-075.0-050.0-E	70.0	75.0	50.0	47.0		
S-070.0-075.0-060.0-E	70.0	75.0	60.0	56.4		
S-072.0-077.0-065.0-E	72.0	77.0	65.0	62.8		
S-075.0-080.0-080.0-E	75.0	80.0	80.0	80.3		
S-080.0-085.0-060.0-E	80.0	85.0	60.0	64.1		
S-080.0-085.0-095.0-E	80.0	85.0	95.0	101.6		

The data and specifications in this publication have been carefully compiled and are believed to be accurate and correct. However, it is the responsibility of the user to determine and ensure the suitability of Pacific Bearing® products for a specific application. Pacific Bearing's only obligation will be to repair or replace without charge, any defective components if returned promptly. No liability is assumed beyond such replacement. *Consult www.pacific-bearing.com for the latest technical updates.



Simplicity® Plane Bearings

Ultra High Temperature Resistant A - Polymer Series

Linear Motion Systems

A

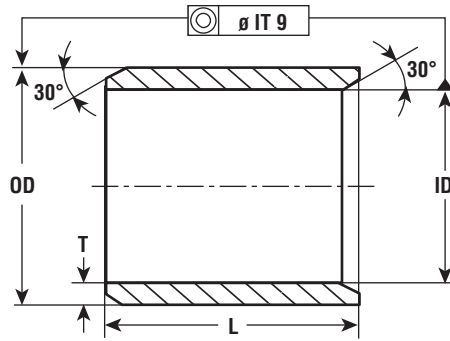

ORDERING INFORMATION

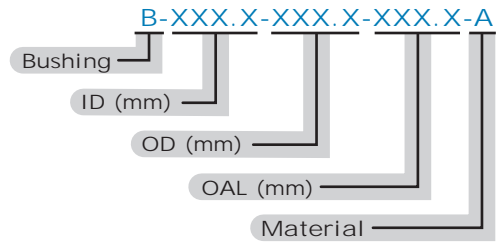

PART NUMBER	DIMENSION			WEIGHT [g]	FITTING TOLERANCE	
	ID [mm]	OD [mm]	L [mm]		HOUSING H7 [mm]	ID AFTER FITTING: F10 [mm]
B-003.0-004.5-006.0-A	3.0	4.5	6.0	0.08	+0.012 0	+0.046 +0.006
B-004.0-005.5-008.0-A	4.0	5.5	8.0	0.13	+0.015 0	+0.058 +0.010
B-005.0-007.0-005.0-A	5.0	7.0	5.0	0.14		
B-005.0-007.0-015.0-A	5.0	7.0	15.0	0.42		
B-006.0-008.0-020.0-A	6.0	8.0	20.0	0.65		
B-008.0-010.0-015.0-A	8.0	10.0	15.0	0.63		
B-008.0-012.0-012.0-A	8.0	12.0	12.0	1.12	+0.018 0	+0.071 +0.013
B-010.0-012.0-012.0-A	10.0	12.0	12.0	0.61		
B-010.0-012.0-020.0-A	10.0	12.0	20.0	1.02		
B-012.0-014.0-020.0-A	12.0	14.0	20.0	1.21		
B-014.0-016.0-012.0-A	14.0	16.0	12.0	0.84		
B-014.0-016.0-025.0-A	14.0	16.0	25.0	1.74		
B-015.0-017.0-025.0-A	15.0	17.0	25.0	1.86		
B-016.0-018.0-020.0-A	16.0	18.0	20.0	1.58		
B-020.0-023.0-010.0-A	20.0	23.0	10.0	1.50		
B-020.0-023.0-015.0-A	20.0	23.0	15.0	2.25		
B-020.0-023.0-020.0-A	20.0	23.0	20.0	3.00	+0.021 0	+0.104 +0.020
B-020.0-023.0-030.0-A	20.0	23.0	30.0	4.50		
B-025.0-028.0-030.0-A	25.0	28.0	30.0	5.54		
B-030.0-034.0-015.0-A	30.0	34.0	15.0	4.46		
B-030.0-034.0-040.0-A	30.0	34.0	40.0	11.90		
B-035.0-039.0-050.0-A	35.0	39.0	50.0	17.20	+0.025 0	+0.125
B-040.0-044.0-050.0-A	40.0	44.0	50.0	19.53		
B-045.0-050.0-050.0-A	45.0	50.0	50.0	27.61		
B-050.0-055.0-060.0-A	50.0	55.0	60.0	36.62		
B-060.0-065.0-070.0-A	60.0	65.0	70.0	50.85	+0.030 0	+0.150 +0.030
B-070.0-075.0-040.0-A	70.0	75.0	40.0	33.71		
B-070.0-075.0-080.0-A	70.0	75.0	80.0	67.42		
B-075.0-080.0-060.0-A	75.0	80.0	60.0	54.05		
B-080.0-085.0-080.0-A	80.0	85.0	80.0	76.72	+0.035 0	+0.176 +0.036
B-090.0-095.0-090.0-A	90.0	95.0	90.0	96.77		
B-100.0-105.0-090.0-A	100.0	105.0	90.0	107.23		

The data and specifications in this publication have been carefully compiled and are believed to be accurate and correct. However, it is the responsibility of the user to determine and ensure the suitability of Pacific Bearing® products for a specific application. Pacific Bearing's only obligation will be to repair or replace without charge, any defective components if returned promptly. No liability is assumed beyond such replacement. *Consult www.pacific-bearing.com for the latest technical updates.



Simplicity® Plane Bearings

Ultra High Temperature Resistant A - Polymer Series

Linear Motion Systems

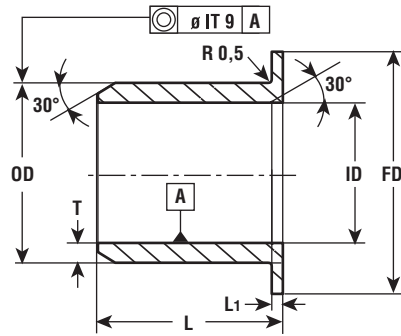

ORDERING INFORMATION

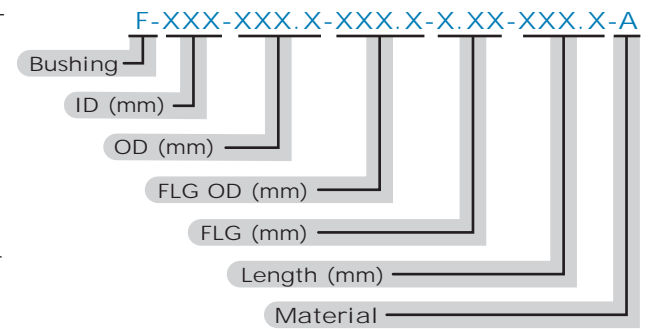

A

PART NUMBER	DIMENSION					WEIGHT [g]	FITTING TOLERANCE	
	ID [mm]	OD [mm]	FD [MM] [mm]	L1 [mm]	L [mm]		HOUSING H7 [mm]	ID AFTER FITTING: F10 [mm]
F-002-003.5-004.8-0.50-004.0-A	2.0	3.5	4.8	0.50	4.0	0.04	+0.012 0	+0.046 +0.006
F-004-005.5-009.5-0.75-004.0-A	4.0	5.5	9.5	0.75	4.0	0.12		+0.058 +0.010
F-005-007.0-011.0-1.00-005.0-A	5.0	7.0	11.0	1.00	5.0	0.22	+0.015 0	+0.071 +0.013
F-006-008.0-012.0-1.00-010.0-A	6.0	8.0	12.0	1.00	10.0	0.42		+0.086 +0.016
F-008-010.0-015.0-1.00-009.5-A	8.0	10.0	15.0	1.00	9.5	0.54	+0.018 0	+0.086 +0.016
F-010-012.0-018.0-1.00-012.0-A	10.0	12.0	18.0	1.00	12.0	0.82		
F-010-012.0-018.0-1.00-017.0-A	10.0	12.0	18.0	1.00	17.0	1.08		
F-010-012.0-018.0-1.00-020.0-A	10.0	12.0	18.0	1.00	20.0	1.23		
F-012-014.0-020.0-1.00-020.0-A	12.0	14.0	20.0	1.00	20.0	1.45		
F-014-016.0-022.0-1.00-017.0-A	14.0	16.0	22.0	1.00	17.0	1.45		
F-015-017.0-023.0-1.00-020.0-A	15.0	17.0	23.0	1.00	20.0	1.77		
F-016-018.0-024.0-1.00-012.0-A	16.0	18.0	24.0	1.00	12.0	1.24		
F-016-018.0-024.0-1.00-020.0-A	16.0	18.0	24.0	1.00	20.0	1.87		
F-018-020.0-026.0-1.00-014.0-A	18.0	20.0	26.0	1.00	14.0	1.56		
F-018-020.0-026.0-1.00-020.0-A	18.0	20.0	26.0	1.00	20.0	2.09	+0.021 0	+0.104 +0.020
F-018-020.0-024.0-2.00-022.0-A	18.0	20.0	24.0	2.00	22.0	2.35		
F-020-023.0-030.0-1.50-016.5-A	20.0	23.0	30.0	1.50	16.5	3.12		
F-020-023.0-030.0-2.00-020.0-A	20.0	23.0	30.0	2.00	20.0	3.86		
F-020-023.0-030.0-1.50-021.5-A	20.0	23.0	30.0	1.50	21.5	3.87		
F-025-028.0-035.0-1.50-021.5-A	25.0	28.0	35.0	1.50	21.5	4.74		
F-028-030.0-034.0-1.00-006.0-A	28.0	30.0	34.0	1.00	6.0	1.11		

The data and specifications in this publication have been carefully compiled and are believed to be accurate and correct. However, it is the responsibility of the user to determine and ensure the suitability of Pacific Bearing® products for a specific application. Pacific Bearing's only obligation will be to repair or replace without charge, any defective components if returned promptly. No liability is assumed beyond such replacement. *Consult www.pacific-bearing.com for the latest technical updates.



Simplicity® Plane Bearings

Ultra High Temperature Resistant A - Polymer Series

Linear Motion Systems

A

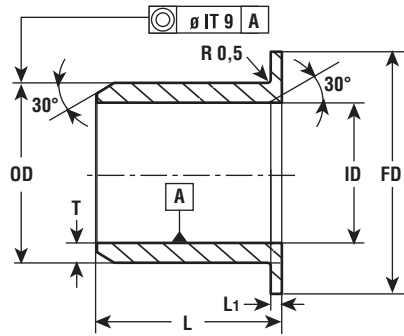

ORDERING INFORMATION

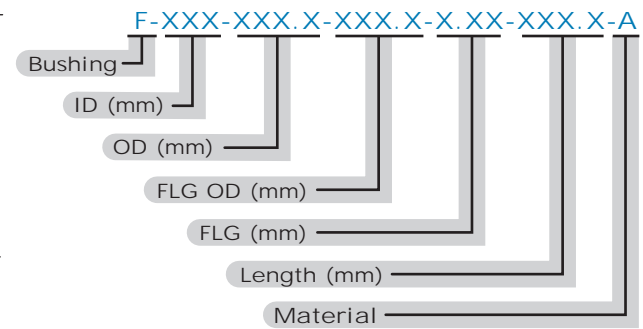

PART NUMBER	DIMENSION					WEIGHT [g]	FITTING TOLERANCE			
	ID [mm]	OD [mm]	FD [mm]	L1 [mm]	L [mm]		HOUSING H7 [mm]	ID AFTER FITTING: F10 [mm]		
F-030-034.0-042.0-2.00-026.0-A	30.0	34.0	42.0	2.00	26.0	9.15	+0.025 0	+0.104 +0.020		
F-030-034.0-045.0-2.00-037.0-A	30.0	34.0	45.0	2.00	37.0	13.03		+0.125 +0.025		
F-035-039.0-050.0-2.00-040.0-A	35.0	39.0	50.0	2.00	40.0	16.04				
F-035-039.0-050.0-2.00-050.0-A	35.0	39.0	50.0	2.00	50.0	19.48				
F-040-044.0-055.0-2.00-016.0-A	40.0	44.0	55.0	2.00	16.0	8.78				
F-040-044.0-052.0-2.00-030.0-A	40.0	44.0	52.0	2.00	30.0	13.50				
F-040-044.0-055.0-2.00-040.0-A	40.0	44.0	55.0	2.00	40.0	18.15				
F-045-050.0-058.0-2.50-026.0-A	45.0	50.0	58.0	2.50	26.0	16.87				
F-045-050.0-058.0-2.40-050.0-A	45.0	50.0	58.0	2.40	50.0	30.02				
F-050-055.0-065.0-2.50-050.0-A	50.0	55.0	65.0	2.50	50.0	34.00			+0.030 0	+0.150 +0.030
F-050-057.5-063.0-2.50-012.0-A	50.0	57.5	63.0	2.50	12.0	13.17				
F-055-060.0-070.0-2.50-060.0-A	55.0	60.0	70.0	2.50	60.0	43.88				
F-060-065.0-075.0-2.50-040.0-A	60.0	65.0	75.0	2.50	40.0	33.13				
F-060-065.0-075.0-2.50-070.0-A	60.0	65.0	75.0	2.50	70.0	54.92				
F-065-070.0-080.0-2.50-060.0-A	65.0	70.0	80.0	2.50	60.0	51.44				
F-070-075.0-085.0-2.50-070.0-A	70.0	75.0	85.0	2.50	70.0	63.64				
F-070-075.0-085.0-2.50-080.0-A	70.0	75.0	85.0	2.50	80.0	72.07				
F-080-085.0-095.0-2.50-080.0-A	80.0	85.0	95.0	2.50	80.0	81.95	+0.035 0	+0.176 +0.036		
F-090-095.0-110.0-2.50-090.0-A	90.0	95.0	110.0	2.50	90.0	105.70				
F-100-105.0-130.0-2.50-090.0-A	100.0	105.0	130.0	2.50	90.0	124.30				

The data and specifications in this publication have been carefully compiled and are believed to be accurate and correct. However, it is the responsibility of the user to determine and ensure the suitability of Pacific Bearing® products for a specific application. Pacific Bearing's only obligation will be to repair or replace without charge, any defective components if returned promptly. No liability is assumed beyond such replacement. *Consult www.pacific-bearing.com for the latest technical updates.



TOLERANCE

Polymer plane bearings are suitable as press-in bushing, preferably used in housings with tolerance H7. The press fit oversize depends on the nominal diameter and the respective material. The press fit oversize is about 0.5 - 1.5% according to the chosen diameter.

After assembly in the inside diameter adjusts itself to the nominal value. A certain clearance in the bearing is necessary to guarantee faultless operation under all operational conditions. Inside diameter lies in the range of tolerance F10 according to compound.

Shafts are mainly in tolerance h9 - h7. The ideal sliding counterpart is steel with a ground surface (surface roughness value with parameter Ra 0.4 to 0.8 μm) and a minimum hardness of 50 HRC. Apart from hardened steel nearly all other common shaft materials can be used: stainless steel, carbon steel, non-ferrous metals and plastics. Special compounds are available for soft shafts made for example out of non-ferrous metals or aluminum alloys. Thus, we can achieve very low to no wear in the sliding counterpart.

For special applications please contact us. We are able to formulate service life on the basis of our tests for and experience from a huge number of applications.

MACHINING

Polymer plane bearings can be reworked without problem.

Milling, turning on a lathe, sawing or cutting can be done, however, please do not alter I.D.

LUBRICATION

Compound plane bearings are self-lubricating and therefore maintenance-free. Nevertheless, initial lubrication during assembly or cooling by environmental media can multiply loading capacity and service life. The compounds are resistant against most of the common greases and oils. Detailed information can be obtained from the chemicals resistance list in this catalog or you can receive a detailed list on request.

ASSEMBLY

It is preferable to press polymer plane bearings into the housing with an arbor parallel to the axis. The one-sided chamfer on the bearing simplifies assembly. A similar chamfer should also be part of the housing.

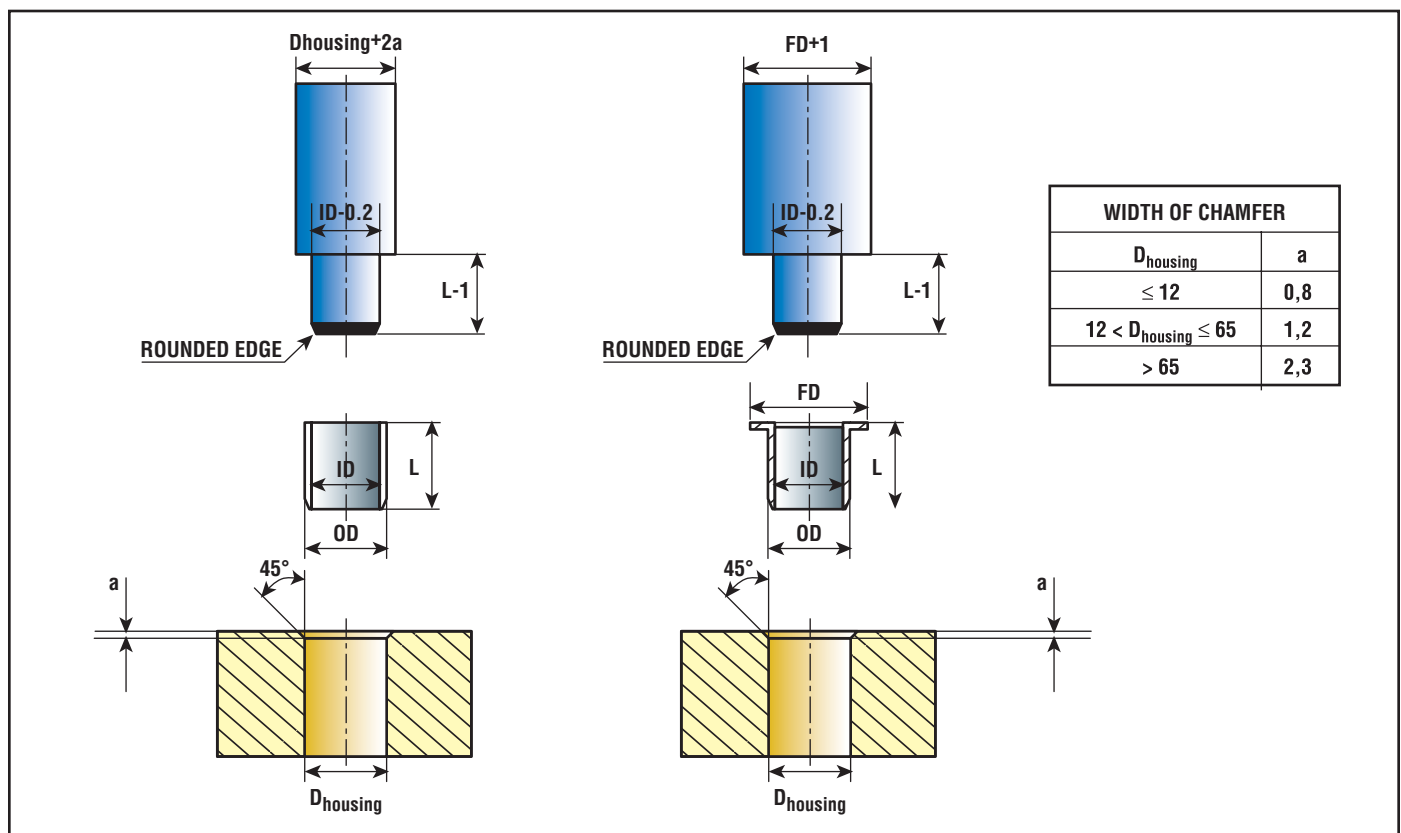

The data and specifications in this publication have been carefully compiled and are believed to be accurate and correct. However, it is the responsibility of the user to determine and ensure the suitability of Pacific Bearing® products for a specific application. Pacific Bearing's only obligation will be to repair or replace without charge, any defective components if returned promptly. No liability is assumed beyond such replacement. *Consult www.pacific-bearing.com for the latest technical updates.



HOW THE SURROUNDINGS INFLUENCE PLANE BEARINGS

Polymer plane bearings made of specially modified compounds for the best operating results in maintenance-poor or maintenance-free surroundings. Through many years of experiences we have continuously improved our materials. Today, we are able to cover a large segment of applications with our products.

Many factors have an influence on the successful operation of plane bearings. Temperature is a determining factor. Polymers change their properties more radically at different temperatures than conventional metal-polymer bearings.

Approximate values and orientation cannot replace a test under real everyday conditions of a system. Check operational temperature, loads, life, safety and the insertion tolerance and lubrication edge pressures or unwanted inclusion of dirt particles.

NOMENCLATURE

The following parameters and variables are being used:

TERM	FORMULA TYPE	UNIT
radial bearing load	F	N
inner diameter	d	mm
bushing width	L	mm
wall thickness	s	mm
sliding speed	v	m/s
coefficient of friction	ϑ	
environment temperature	ϑ_U	°C
max. sliding surface temperature	ϑ_{max}	°C
specific load	ρ	MPa
revolutions per minute	n	U/min
rotation angle	φ	°
compensation constant PV-value	k_1, k_2	
thermal conductivity compound	λ_C	W/mK
thermal conductivity shaft	λ_W	W/mK

The data and specifications in this publication have been carefully compiled and are believed to be accurate and correct. However, it is the responsibility of the user to determine and ensure the suitability of Pacific Bearing® products for a specific application. Pacific Bearing's only obligation will be to repair or replace without charge, any defective components if returned promptly. No liability is assumed beyond such replacement. *Consult www.pacific-bearing.com for the latest technical updates.



AVERAGE LOAD

The active radial force affecting the plane bearing and the projected supporting surface combine to the average load. The value results from this formula:

$$\bar{p} = \frac{F}{d \cdot L} [N/mm^2]$$

SLIDING SPEED

Sliding speed is either the direct result of the linear speed or with rotating movements results from the revs:

$$v = \frac{n \cdot d \cdot \pi}{1000 \cdot 60} [m/s]$$

or with oscillator movements result in:

$$v = \frac{d \cdot \pi}{60 \cdot 100} \cdot \frac{2\varphi \cdot n}{360} [m/s]$$

PERMISSIBLE PV VALUE

The permissible PV value is the product of sliding speed and the corresponding load allowance. With polymer plane bearings the PV value can be determined via the following formula:

$$\bar{p}v_{zmax} = \frac{\pi \cdot \Delta\vartheta}{\mu} \left(\frac{k_1 \cdot \lambda_c}{s} + \frac{k_2 \cdot \lambda_w}{2L} \right) \cdot 10^{-3} [MP\alpha \cdot \frac{m}{s}]$$

and

$$\Delta\vartheta = \vartheta_{max} - \vartheta_u$$

The permissible PV value should be greater or equal to the PV value formulated from speed and load data for the final application!

LIFE EXPECTANCY OF A PLANE BEARING

To calculate the service life the complete group of possible strains must be taken into consideration. If in doubt, talk to a member of our skilled and experienced technical staff. They will help you interpreting and calculating the length of service life.

The following correction factors apply:

BUSHING WALL THICKNESS <i>s</i>	<i>k</i> ₁	<i>k</i> ₂
≤ 2 mm	0.50	0.042
> 2 mm	0.75	0.058

The following thermal conductivities have to be applied to the shaft material:

MATERIAL	SHAFT THERMAL CONDUCTIVITY λ [W/mK]
Aluminum bronze	120
Aluminum alloy	156
Brass	80
Bronze	46
Carbon Steel	46
Cast iron	60
Low alloy steel	55
Phosphor bronze	75
Stainless steel	15

The data and specifications in this publication have been carefully compiled and are believed to be accurate and correct. However, it is the responsibility of the user to determine and ensure the suitability of Pacific Bearing® products for a specific application. Pacific Bearing's only obligation will be to repair or replace without charge, any defective components if returned promptly. No liability is assumed beyond such replacement. *Consult www.pacific-bearing.com for the latest technical updates.



Simplicity® Plane Bearings

Sleeve Bearings - Inch Series

Linear Motion Systems

PS SLEEVE BEARINGS

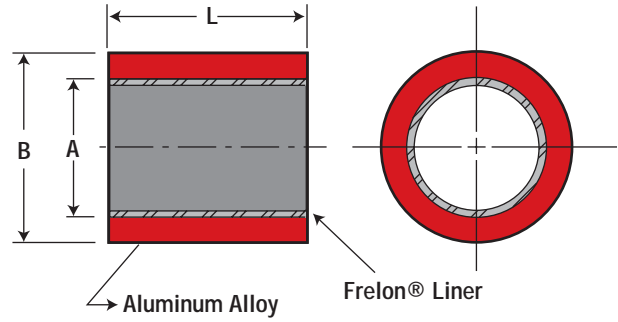

BASIC DIMENSIONAL INFORMATION

PART NO.	NOMINAL BEARING SIZE			A BEARING I.D.		B O.D.		L LENGTH		MAX. STATIC LOAD (lbs.) FRELON		BEARING WEIGHT (oz.)	RECOMMENDED HOUSING BORE			
	I.D.	O.D.	LENGTH	MIN.	MAX.	MIN.	MAX.	MIN.	MAX.	GOLD	J		SLIP FIT & EPOXY		PRESS FIT	
													MIN.	MAX.	MIN.	MAX.
PS0305-02	3/16"	5/16"	1/4"	0.1890	0.1900	0.3135	0.3145	0.230	0.250	130	65	0.02	0.3145	0.3155	0.3125	0.3130
PS0305-04	3/16"	5/16"	1/2"	0.1890	0.1900	0.3135	0.3145	0.480	0.500	272	136	0.04	0.3145	0.3155	0.3125	0.3130
PS0406-02	1/4"	3/8"	1/4"	0.2515	0.2525	0.3760	0.3770	0.230	0.250	174	87	0.03	0.3770	0.3780	0.3750	0.3755
PS0406-03	1/4"	3/8"	3/8"	0.2515	0.2525	0.3760	0.3770	0.355	0.375	268	134	0.04	0.3770	0.3780	0.3750	0.3755
PS0406-04	1/4"	3/8"	1/2"	0.2515	0.2525	0.3760	0.3770	0.480	0.500	362	181	0.05	0.3770	0.3780	0.3750	0.3755
PS0610-04	3/8"	5/8"	1/2"	0.3765	0.3775	0.6260	0.6270	0.480	0.500	542	271	0.14	0.6270	0.6280	0.6250	0.6255
PS0610-06	3/8"	5/8"	3/4"	0.3765	0.3775	0.6260	0.6270	0.730	0.750	824	412	0.20	0.6270	0.6280	0.6250	0.6255
PS0710-06	7/16"	5/8"	3/4"	0.4390	0.4400	0.6260	0.6270	0.730	0.750	962	481	0.23	0.6270	0.6280	0.6250	0.6255
PS0812-04	1/2"	3/4"	1/2"	0.5015	0.5025	0.7510	0.7520	0.480	0.500	722	361	0.15	0.7520	0.7530	0.7500	0.7505
PS0812-06	1/2"	3/4"	3/4"	0.5015	0.5025	0.7510	0.7520	0.730	0.750	1098	549	0.25	0.7520	0.7530	0.7500	0.7505
PS0812-08	1/2"	3/4"	1"	0.5015	0.5025	0.7510	0.7520	0.980	1.000	1474	737	0.35	0.7520	0.7530	0.7500	0.7505
PS1014-06	5/8"	7/8"	3/4"	0.6265	0.6275	0.8760	0.8770	0.730	0.750	1372	686	0.30	0.8770	0.8780	0.8750	0.8755
PS1014-08	5/8"	7/8"	1"	0.6265	0.6275	0.8760	0.8770	0.980	1.000	1842	921	0.45	0.8770	0.8780	0.8750	0.8755
PS1216-08	3/4"	1"	1"	0.7515	0.7525	1.0010	1.0020	0.980	1.000	2210	1105	0.50	1.0020	1.0030	0.9995	1.0000
PS1620-12	1"	1-1/4"	1-1/2"	1.0015	1.0025	1.2510	1.2520	1.480	1.500	4446	2223	0.95	1.2520	1.2530	1.2490	1.2500
PS2024-16	1-1/4"	1-1/2"	2"	1.2515	1.2525	1.5010	1.5020	1.980	2.000	7434	3717	1.55	1.5020	1.5030	1.4990	1.5000
PS2428-16	1-1/2"	1-3/4"	2"	1.5015	1.5025	1.7510	1.7520	1.980	2.000	8918	4459	1.80	1.7520	1.7530	1.7490	1.7500
PS2832-24	1-3/4"	2"	3"	1.7515	1.7525	2.0010	2.0020	2.980	3.000	15658	7829	3.15	2.0020	2.0030	1.9990	2.0000
PS3236-24	2"	2-1/4"	3"	2.0015	2.0025	2.2510	2.2520	2.980	3.000	17894	8947	3.55	2.2520	2.2530	2.2490	2.2500
PS4044-24	2-1/2"	2-3/4"	3"	2.5015	2.5025	2.7510	2.7520	2.980	3.000	22364	11182	4.85	2.7520	2.7530	2.7490	2.7500
PS4852-28	3"	3-1/4"	3-1/2"	3.0015	3.0025	3.2510	3.2520	3.480	3.500	31336	15668	6.10	3.2520	3.2530	3.2485	3.2495

INSTALLATION INSTRUCTIONS

- Slip the bearing sleeve into the housing and epoxy into place with Loctite® or similar type bonding agent.
CAUTION: Do NOT let any of the adhesive touch the bearing liner. It will harden and interfere with the running clearance.
- Freeze the bearings at 0°F (-17.75°C) for 30-45 minutes. Using gloves, remove the bearings from the freezer and slip them into the housing. As they heat to room temperature, full contact between the bearing and housing will be achieved. The greatest advantage to this technique over traditional pressing is greater accuracy in alignment.

ORDERING INFORMATION

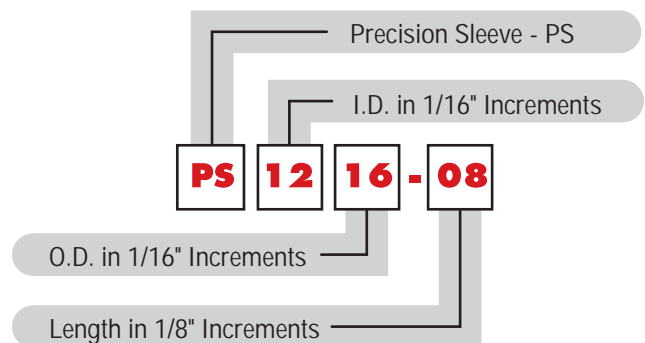

NOTE: Lengths not listed above must be specially quoted.

FrelonGOLD® and FrelonJ® are registered trademarks of Pacific Bearing.

The data and specifications in this publication have been carefully compiled and are believed to be accurate and correct. However, it is the responsibility of the user to determine and ensure the suitability of Pacific Bearing® products for a specific application. Pacific Bearing's only obligation will be to repair or replace without charge, any defective components if returned promptly. No liability is assumed beyond such replacement. *Consult www.pacific-bearing.com for the latest technical updates.



PSF SLEEVE BEARINGS

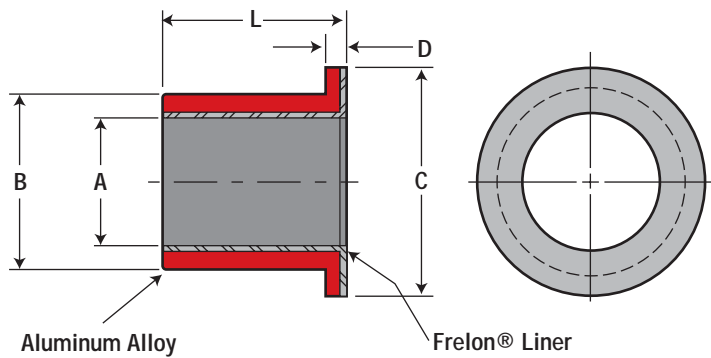

BASIC DIMENSIONAL INFORMATION

PART NO.	NOMINAL BEARING SIZE			A BEARING I.D.		B O.D.		C FLANGE O.D.	D FLANGE WIDTH	L LENGTH		MAX. STATIC LOAD (lbs.) FRELON		BEARING WEIGHT (oz.)	RECOMMENDED HOUSING BORE			
				MIN.	MAX.	MIN.	MAX.	MIN.	MAX.	MIN.	MAX.	GOLD	J		SLIP FIT & EPOXY		PRESS FIT	
	I.D.	O.D.	LENGTH	MIN.	MAX.	MIN.	MAX.	MIN.	MAX.	MIN.	MAX.			MIN.	MAX.	MIN.	MAX.	
PSF0305-02	3/16"	5/16"	1/4"	0.1890	0.1900	0.3135	0.3145	0.4370	0.0625	0.230	0.250	130	65	0.023	0.3145	0.3155	0.3125	0.3130
PSF0305-04	3/16"	5/16"	1/2"	0.1890	0.1900	0.3135	0.3145	0.4370	0.0625	0.480	0.500	272	136	0.044	0.3145	0.3155	0.3125	0.3130
PSF0406-02	1/4"	3/8"	1/4"	0.2515	0.2525	0.3760	0.3770	0.5000	0.0625	0.230	0.250	174	87	0.031	0.3770	0.3780	0.3750	0.3755
PSF0406-03	1/4"	3/8"	3/8"	0.2515	0.2525	0.3760	0.3770	0.5000	0.0625	0.355	0.375	268	134	0.044	0.3770	0.3780	0.3750	0.3755
PSF0406-04	1/4"	3/8"	1/2"	0.2515	0.2525	0.3760	0.3770	0.5000	0.0625	0.480	0.500	362	181	0.055	0.3770	0.3780	0.3750	0.3755
PSF0610-04	3/8"	5/8"	1/2"	0.3765	0.3775	0.6260	0.6270	0.8750	0.1250	0.480	0.500	542	271	0.20	0.6270	0.6280	0.6250	0.6255
PSF0610-06	3/8"	5/8"	3/4"	0.3765	0.3775	0.6260	0.6270	0.8750	0.1250	0.730	0.750	824	412	0.25	0.6270	0.6280	0.6250	0.6255
PSF0710-06	7/16"	5/8"	3/4"	0.4390	0.4400	0.6260	0.6270	0.9375	0.1250	0.730	0.750	962	481	0.20	0.6270	0.6280	0.6250	0.6255
PSF0812-04	1/2"	3/4"	1/2"	0.5015	0.5025	0.7510	0.7520	1.0000	0.1250	0.480	0.500	722	361	0.25	0.7520	0.7530	0.7500	0.7505
PSF0812-06	1/2"	3/4"	3/4"	0.5015	0.5025	0.7510	0.7520	1.0000	0.1250	0.730	0.750	1098	549	0.30	0.7520	0.7530	0.7500	0.7505
PSF0812-08	1/2"	3/4"	1"	0.5015	0.5025	0.7510	0.7520	1.0000	0.1250	0.980	1.000	1474	737	0.40	0.7520	0.7530	0.7500	0.7505
PSF1014-06	5/8"	7/8"	3/4"	0.6265	0.6275	0.8760	0.8770	1.0000	0.1250	0.730	0.750	1372	686	0.35	0.8770	0.8780	0.8750	0.8755
PSF1014-08	5/8"	7/8"	1"	0.6265	0.6275	0.8760	0.8770	1.0000	0.1250	0.980	1.000	1842	921	0.45	0.8770	0.8780	0.8750	0.8755
PSF1216-08	3/4"	1"	1"	0.7515	0.7525	1.0010	1.0020	1.2500	0.1250	0.980	1.000	2210	1105	0.55	1.0020	1.0030	0.9995	1.0000
PSF1620-12	1"	1-1/4"	1-1/2"	1.0015	1.0025	1.2510	1.2520	1.5000	0.1250	1.480	1.500	4446	2223	1.05	1.2520	1.2530	1.2490	1.2500
PSF2024-16	1-1/4"	1-1/2"	2"	1.2515	1.2525	1.5010	1.5020	1.7500	0.1250	1.980	2.000	7434	3717	1.80	1.5020	1.5030	1.4990	1.5000
PSF2428-16	1-1/2"	1-3/4"	2"	1.5015	1.5025	1.7510	1.7520	2.0000	0.1250	1.980	2.000	8918	4459	2.16	1.7520	1.7530	1.7490	1.7500
PSF2832-24	1-3/4"	2"	3"	1.7515	1.7525	2.0010	2.0020	2.2500	0.1250	2.980	3.000	15658	7829	3.30	2.0020	2.0030	1.9990	2.0000
PSF3236-24	2"	2-1/4"	3"	2.0015	2.0025	2.2510	2.2520	2.5000	0.1250	2.980	3.000	17894	8947	3.75	2.2520	2.2530	2.2490	2.2500
PSF4044-24	2-1/2"	2-3/4"	3"	2.5015	2.5025	2.7510	2.7520	3.0000	0.1250	2.980	3.000	22364	11182	4.60	2.7520	2.7530	2.7490	2.7500
PSF4852-28	3"	3-1/4"	3-1/2"	3.0015	3.0025	3.2510	3.2520	3.5000	0.1250	3.480	3.500	31336	15668	6.30	3.2520	3.2530	3.2485	3.2495

Sleeve Bearings

INSTALLATION INSTRUCTIONS

- Slip the bearing sleeve into the housing and epoxy into place with Loctite® or similar type bonding agent.
CAUTION: Do NOT let any of the adhesive touch the bearing liner. It will harden and interfere with the running clearance.
- Freeze the bearings at 0°F (-17.75°C) for 30-45 minutes. Using gloves, remove the bearings from the freezer and slip them into the housing. As they heat to room temperature, full contact between the bearing and housing will be achieved. The greatest advantage to this technique over traditional pressing is greater accuracy in alignment.

ORDERING INFORMATION

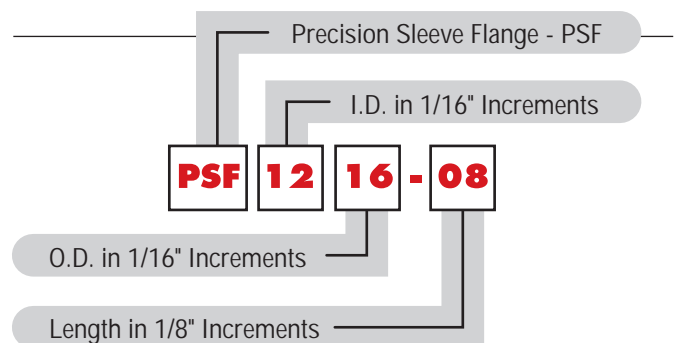

NOTE: Lengths not listed above must be specially quoted.

FrelonGOLD® and FrelonJ® are registered trademarks of Pacific Bearing.

The data and specifications in this publication have been carefully compiled and are believed to be accurate and correct. However, it is the responsibility of the user to determine and ensure the suitability of Pacific Bearing® products for a specific application. Pacific Bearing's only obligation will be to repair or replace without charge, any defective components if returned promptly. No liability is assumed beyond such replacement. *Consult www.pacific-bearing.com for the latest technical updates.



PSFM SLEEVE BEARINGS

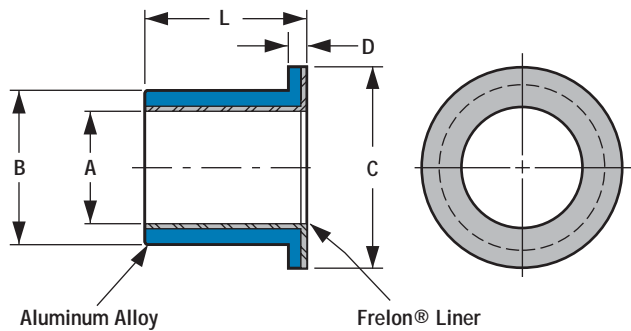

BASIC DIMENSIONAL INFORMATION

PART NO.	NOMINAL BEARING SIZE			A BEARING I.D.		B O.D. (S)		C FLANGE O.D.	D FLANGE WIDTH	L LENGTH		MAX. STATIC LOAD (kg.) FRELON		MAX. STATIC LOAD (N) FRELON		BEARING WEIGHT (kg.)	RECOMMENDED HOUSING BORE			
	I.D.	O.D.	LENGTH	MIN.	MAX.	MIN.	MAX.	MIN.	MAX.	MIN.	MAX.	GOLD	J	GOLD	J		SLIP FIT & EPOXY	PRESS FIT		
PSFM0610-06	6	10	6	6.028	6.058	10.023	10.038	14	2	5.75	6	76	38	745	373	0.00126	10.038	10.063	10.000	10.015
PSFM0610-10	6	10	10	6.028	6.058	10.023	10.038	14	2	9.75	10	126	63	1236	618	0.00182	10.038	10.063	10.000	10.015
PSFM0812-06	8	12	6	8.033	8.066	12.028	12.046	16	2	5.75	6	100	50	981	490	0.00153	12.046	12.071	12.000	12.018
PSFM0812-08	8	12	8	8.033	8.066	12.028	12.046	16	2	7.75	8	134	67	1314	657	0.00189	12.046	12.071	12.000	12.018
PSFM0812-12	8	12	12	8.033	8.066	12.028	12.046	16	2	11.75	12	202	101	1981	990	0.00259	12.046	12.071	12.000	12.018
PSFM1016-08	10	16	8	10.033	10.066	16.028	16.046	22	3	7.75	8	168	84	1647	824	0.00421	16.046	16.071	16.000	16.018
PSFM1016-10	10	16	10	10.033	10.066	16.028	16.046	22	3	9.75	10	210	105	2059	1030	0.00489	16.046	16.071	16.000	16.018
PSFM1016-16	10	16	16	10.033	10.066	16.028	16.046	22	3	15.75	16	336	168	3295	1647	0.00694	16.046	16.071	16.000	16.018
PSFM1218-08	12	18	8	12.034	12.070	18.028	18.046	24	3	7.75	8	202	101	1981	990	0.00478	18.046	18.071	18.000	18.018
PSFM1218-12	12	18	12	12.034	12.070	18.028	18.046	24	3	11.75	12	302	151	2961	1481	0.00636	18.046	18.071	18.000	18.018
PSFM1519-16	15	19	16	15.034	15.070	19.028	19.046	25	3	15.50	16	504	252	4942	2471	0.00647	19.046	19.071	19.000	19.018
PSFM1620-16	16	20	16	16.041	16.080	20.035	20.056	27	3	15.55	16	538	269	5276	2638	0.00718	20.056	20.081	20.000	20.021
PSFM1620-20	16	20	20	16.041	16.080	20.035	20.056	27	3	19.50	20	672	336	6590	3295	0.00844	20.056	20.081	20.000	20.021
PSFM1620-25	16	20	25	16.041	16.080	20.035	20.056	27	3	24.50	25	840	420	8237	4119	0.01002	20.056	20.081	20.000	20.021
PSFM2026-20	20	26	20	20.042	20.084	26.035	26.056	32	3	19.50	20	840	420	8237	4119	0.01432	26.056	26.081	26.000	26.021
PSFM2026-30	20	26	30	20.042	20.084	26.035	26.056	32	3	29.50	30	1260	630	12356	6178	0.02035	26.056	26.081	26.000	26.021
PSFM2530-20	25	30	20	25.042	25.084	30.035	30.056	39	3.5	19.50	20	1050	525	10296	5148	0.01672	30.056	30.081	30.000	30.021
PSFM2530-25	25	30	25	25.042	25.084	30.035	30.056	39	3.5	24.50	25	1312	656	12865	6433	0.01973	30.056	30.081	30.000	30.021
PSFM2530-32	25	30	32	25.042	25.084	30.035	30.056	39	3.5	31.50	32	1680	840	16474	8237	0.02394	30.056	30.081	30.000	30.021
PSFM3038-30	30	38	30	30.050	30.096	38.043	38.068	46	4	29.50	30	1890	945	18533	9267	0.04145	38.068	38.093	38.000	38.021
PSFM3545-35	35	45	35	35.052	35.102	45.043	45.068	55	5	34.50	35	2572	1286	25221	12611	0.07192	45.068	45.093	45.000	45.025
PSFM4050-40	40	50	40	40.052	40.102	50.043	50.068	60	5	39.50	40	3360	1680	32948	16474	0.09044	50.068	50.093	50.000	50.025
PSFM5060-50	50	60	50	50.062	50.133	60.053	60.099	70	5	49.50	50	5250	2625	51482	25741	0.13429	60.099	60.124	60.000	60.030

Sleeve Bearings

INSTALLATION INSTRUCTIONS

- Slip the bearing sleeve into the housing and epoxy into place with Loctite™ or similar type bonding agent.
CAUTION: Do NOT let any of the adhesive touch the bearing liner. It will harden and interfere with the running clearance.
- Freeze the bearings at 0°F (-17.75°C) for 30-45 minutes. Using gloves, remove the bearings from the freezer and slip them into the housing. As they heat to room temperature, full contact between the bearing and housing will be achieved. The greatest advantage to this technique over traditional pressing is greater accuracy in alignment.

FrelonGOLD® and FrelonJ® are registered trademarks of Pacific Bearing.

The data and specifications in this publication have been carefully compiled and are believed to be accurate and correct. However, it is the responsibility of the user to determine and ensure the suitability of Pacific Bearing® products for a specific application. Pacific Bearing's only obligation will be to repair or replace without charge, any defective components if returned promptly. No liability is assumed beyond such replacement. *Consult www.pacific-bearing.com for the latest technical updates.

ORDERING INFORMATION

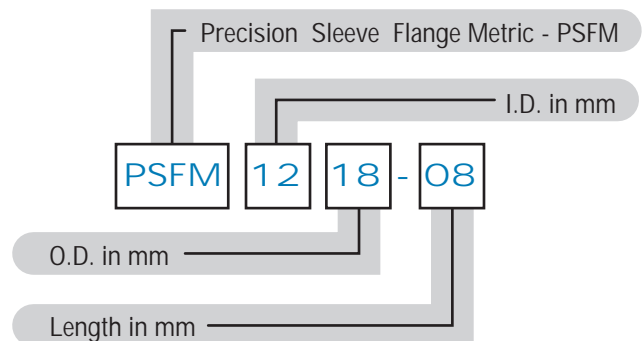

NOTE: Lengths not listed above must be quoted.



SIMPLICITY LINEAR SLIDES WILL EXCEL IN HARSH, CONTAMINATED ENVIRONMENTS

Simplicity slides are working effectively today in some of the toughest environments industry has to offer:

- Fiberglass manufacturing and processing plants
- Stone cutters and other quarry applications
- Auto manufacturing facilities
- Welding and assembly lines
- Foundries
- Machine Tools

THREE BASIC DESIGNS FOR SIMPLICITY® LINEAR SLIDES

NOTE: All slides come standard with mounting plate, four pillow block assemblies, two steel shafts with corrosion resistant finish, two aluminum support rails.

HIGH PROFILE:

RS - comes with standard components

RPS - comes with standard components and includes bottom support plate with precision alignment

2RPS - same as "RPS" with ball screw and two ends supported with end plates

LOW PROFILE:

LRPS - low profile support rail version of a standard RPS

2LRPS - low profile support rail version of a standard 2RPS

MODULAR COMPONENTS:

SRB2 - support rail, guide bar, and two standard Simplicity pillow blocks

SRBT - support rail, guide bar, and one standard Simplicity pillow block

ACCESSORIES AVAILABLE:

Hand crank with ball screw lock, direct drive NEMA 23 & 34 motor bracket with constant velocity coupling, etc.

Call for more information. Special quotation requests for your specific application are welcome!

Many of the toughest applications and environments do not use standard off-the-shelf components. We excel at these challenges. Call our application engineers for an evaluation and quotation on a slide for your needs.

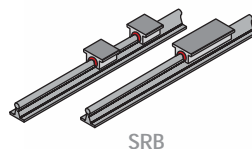

SRB

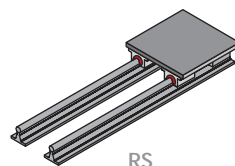

RS

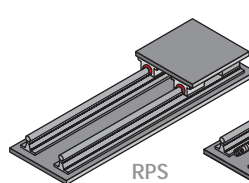

RPS

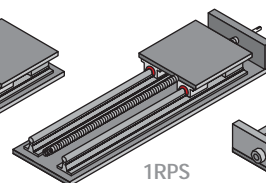

1RPS

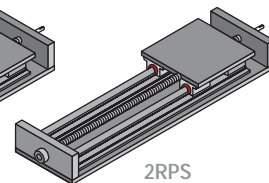

2RPS

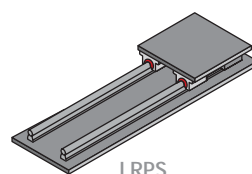

LRPS

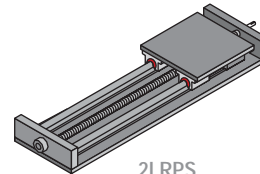

2LRPS

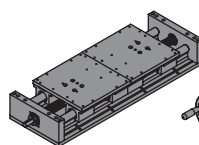

SC2RPS

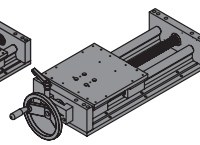

2HCR-2HWL

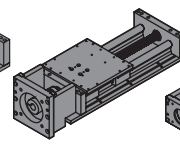

2N42, 56, 143

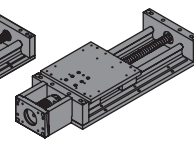

2N34

NOTE: Miniature and unitized Stages and Slides can be found on page 190-191.

Full product specifications are available at www.pacific-bearing.com

The data and specifications in this publication have been carefully compiled and are believed to be accurate and correct. However, it is the responsibility of the user to determine and ensure the suitability of Pacific Bearing® products for a specific application. Pacific Bearing's only obligation will be to repair or replace without charge, any defective components if returned promptly. No liability is assumed beyond such replacement. *Consult www.pacific-bearing.com for the latest technical updates.



SLIDE SELECTION INFORMATION

1. Determine the size and stroke of slide.
2. Is a lube system required?
3. Please furnish the following to the factory:
 - a. Model designation
 - b. Lube system requirements
 - c. Mounting orientation, saddle position if mounted at an angle
 - d. Load to be carried and approximate center of gravity from saddle center
 - e. Location and magnitude of any force which resists the motion of the slide
 - f. Acceleration rate and maximum velocity of the saddle
 - g. Deceleration rate
 - h. Service life requirements
 - i. Type of environment the slide will operate in

MODEL NUMBER

Series Code	Size Code	Length Code	Ball Screw Lead Code
-------------	-----------	-------------	----------------------

MOUNTING ORIENTATION

Please indicate the parameters of your application in the boxes below.

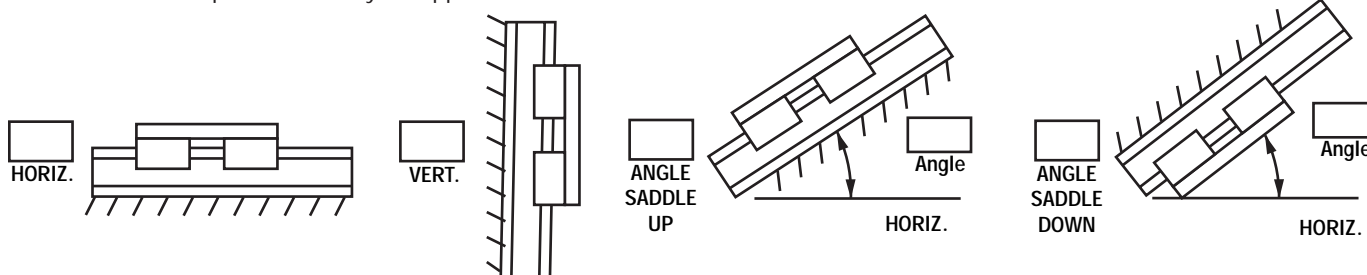

Cycle Rate:	<input type="text"/>	Per Hour:	<input type="text"/>	Per Minute:	<input type="text"/>
Max. Saddle Velocity:	<input type="text"/>	Inch/Second:	<input type="text"/>		
Acceleration Rate:	<input type="text"/>	Inches/Second ² :	<input type="text"/>		
Deceleration Rate:	<input type="text"/>	Inches/Second ² :	<input type="text"/>		
Load:	<input type="text"/>	lbs.	<input type="text"/>		

LOCATION OF CENTER OF GRAVITY FROM SADDLE CENTER

Please indicate the parameters of your application in the boxes below.

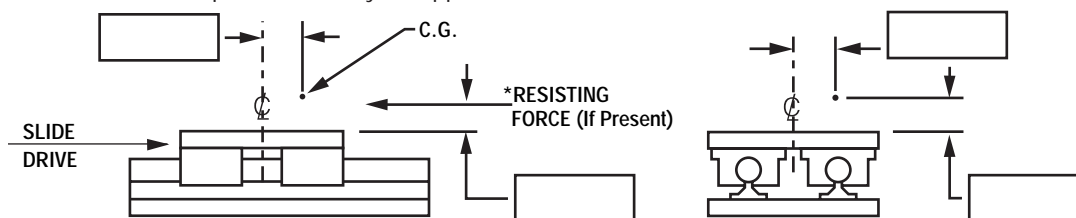

*Example of "Resisting Force" would be tool thrust for a drill head mounted on slide.

Resisting Force:	<input type="text"/>	lbs.
Life Requirement:	<input type="text"/>	Strokes <input type="text"/> Hours

The data and specifications in this publication have been carefully compiled and are believed to be accurate and correct. However, it is the responsibility of the user to determine and ensure the suitability of Pacific Bearing[®] products for a specific application. Pacific Bearing's only obligation will be to repair or replace without charge, any defective components if returned promptly. No liability is assumed beyond such replacement. *Consult www.pacific-bearing.com for the latest technical updates.

Linear Slides



LOAD CAPACITIES

For non-lubricated slide applications where speeds are less than 90 feet/minute (18 inches/seconds).

All slides are to be fully supported and rigidly mounted.

STANDARD MOUNTING

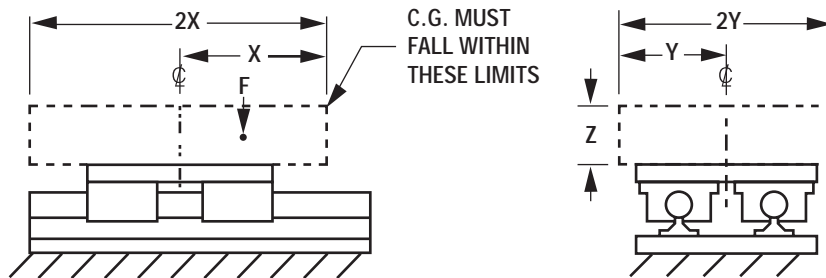

Recommended Safe Loading

SIZE	F MAX. (lbs.)	F MAX. (N)	X (in.)	Y (in.)	Z (in.)
08	1450	2402	4.00	2.37	3.00
10	2200	3381	4.75	2.76	3.50
12	2850	3737	5.00	2.85	4.00
16	5275	4671	5.50	3.37	4.50
20	7750	7784	6.75	4.05	5.50
24	10600	9341	7.86	4.90	6.50
32	18750	14679	10.75	6.00	9.00

SIDE MOUNTING

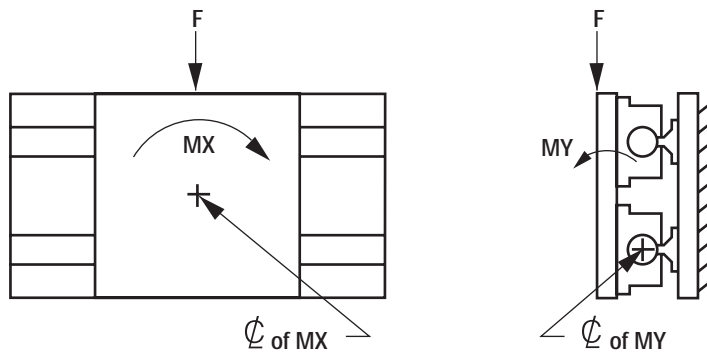

Recommended Safe Loading

SIZE	F MAX. (lbs.)	Mx (in.-lbs.)	My (in.-lbs.)	F MAX. (N)	Mx (Nm)	My (Nm)
08	540	910	1500	2402	103	169
10	760	1680	2750	3381	190	311
12	840	1710	2875	3737	193	325
16	1050	3300	4430	4671	373	501
20	1750	6175	8750	7784	698	989
24	2100	9600	12600	9341	1085	1424
32	3300	19000	28050	14679	2147	3169

The data and specifications in this publication have been carefully compiled and are believed to be accurate and correct. However, it is the responsibility of the user to determine and ensure the suitability of Pacific Bearing® products for a specific application. Pacific Bearing's only obligation will be to repair or replace without charge, any defective components if returned promptly. No liability is assumed beyond such replacement. *Consult www.pacific-bearing.com for the latest technical updates.



LOAD CAPACITIES (cont.)

INVERTED MOUNTING

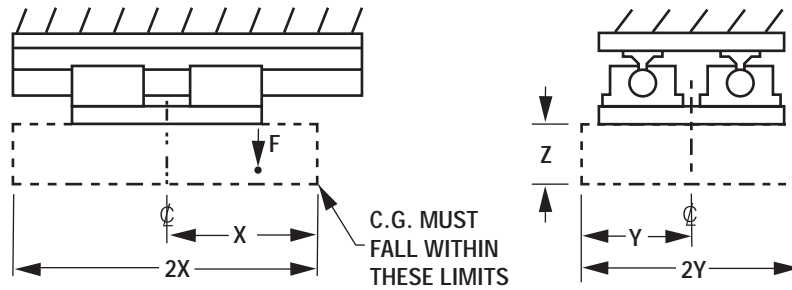

Recommended Safe Loading

SIZE	F MAX. (lbs.)	F MAX. (N)	X (in.)	Y (in.)	Z (in.)
08	195	867	4.85	2.91	3.00
10	285	1268	5.69	3.33	3.50
12	315	1401	6.52	3.75	4.00
16	450	2002	7.31	4.58	4.50
20	712	3167	8.84	5.42	5.50
24	900	4003	10.50	6.67	6.50
32	1425	6339	14.67	8.33	9.00

VERTICAL MOUNTING

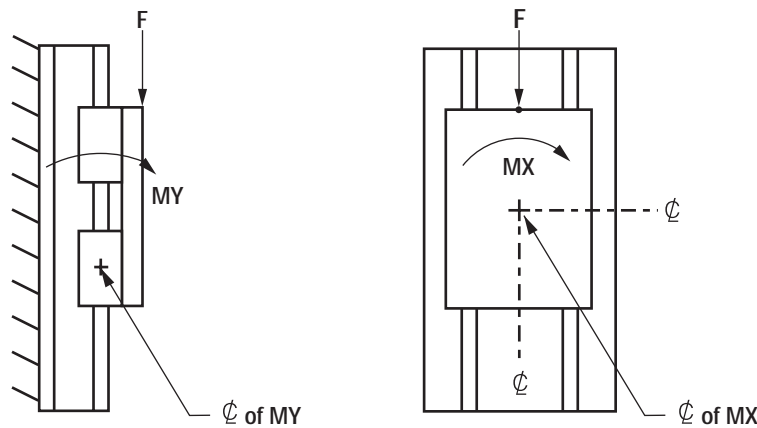

Recommended Safe Loading

SIZE	F MAX. (lbs.) ^{1,2}	M _x (in.-lbs.)	M _y (in.-lbs.)	F MAX. (N)	M _x (Nm)	M _y (Nm)
08	260	1445	1500	1157	163	169
10	300	2750	2750	1334	311	311
12	300	2875	2875	1334	325	325
16	600	5000	4430	2669	565	501
20	675	9500	8750	3003	1073	989
24	710	14400	12600	3158	1627	1424
32	900	32300	28050	4003	3649	3169

¹ Applies only when using 2RPS & 2LRPS slides

² If "F" is exceeded consult factory.

Footnote: w/RPS, FMAX is dependent upon customer's method of moving the slide.

The data and specifications in this publication have been carefully compiled and are believed to be accurate and correct. However, it is the responsibility of the user to determine and ensure the suitability of Pacific Bearing® products for a specific application. Pacific Bearing's only obligation will be to repair or replace without charge, any defective components if returned promptly. No liability is assumed beyond such replacement. *Consult www.pacific-bearing.com for the latest technical updates.

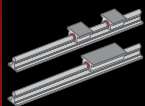

SRB - Preassembled Shaft, Rail, & Bearing

PART NUMBER DIMENSIONS

SERIES	SIZE				L	SHAFT DIA.	A	B	C	D	E _T	F _T	E ₂	F ₂	G	H	J	K	M	N	P	R	S	
SRBXY	X	08	-	XX	-	XXX	.500	1.125	2.00	1.688	1.50	2.500	3.500	1.000	1.687	.250	1.812	4.000	2.00	1.125	.156	.169	1.000	.188
SRBXY	X	10	-	XX	-	XXX	.625	1.125	2.50	2.125	1.62	3.000	4.000	1.125	1.937	.281	2.000	4.000	2.00	1.437	.188	.193	1.125	.250
SRBXY	X	12	-	XX	-	XXX	.750	1.500	2.75	2.375	1.75	3.500	4.500	1.250	2.062	.312	2.438	6.000	3.00	1.562	.188	.221	1.250	.250
SRBXY	X	16	-	XX	-	XXX	1.000	1.750	3.25	2.875	2.12	4.500	6.000	1.750	2.812	.375	2.938	6.000	3.00	1.937	.219	.281	1.500	.250
SRBXY	X	20	-	XX	-	XXX	1.250	2.125	4.00	3.500	2.50	5.500	7.500	2.000	3.625	.437	3.625	6.000	3.00	2.500	.219	.343	1.875	.312
SRBXY	X	24	-	XX	-	XXX	1.500	2.500	4.75	4.125	3.00	6.500	9.000	2.500	4.000	.500	4.250	8.000	4.00	2.875	.281	.343	2.250	.375
SRBXY	X	32	-	XX	-	XXX	2.000	3.250	6.00	5.250	3.75	8.250	10.000	3.250	5.000	.625	5.375	8.000	4.00	3.625	.406	.406	2.750	.500

- Substitute "L" from standard length table for "XXX"
- *Substitute "00" - Alloy Steel, "SS" - 440 Stainless Steel, or "CR" - Chrome Plated 303 SST for "XX"
- Shaft diameter dimension in 1/16" increments
- Enter "S" for single seals or "D" for double seals or leave blank for no seals
- Substitute "X" for "B" - Ball Bearing
- Pillow block style - substitute "2" for two single PN bearings or "T" for one twin PWN bearing for "Y"

All tabulated dimensions are in inches.

MATERIAL:

T-Rail supports - aluminum alloy

***Shafting** - Hardened steel alloy, SS 440 stainless steel and CR 303 SST

Simplicity Bearings - composite teflon and aluminum alloy

Simplicity Pillow Blocks - aluminum alloy

Screws, retaining rings, spring pins - steel alloy

NOTE: For lengths over 48", guide bars will be continuous, but rail supports will have a minimum of one break every 48".

ORDERING EXAMPLE:

To order an assembly with a .750 diameter shaft, support rail and one twin double sealed Simplicity bearing, with a length overall of 96.00", specify part number SRBTD-12-096.

To order an assembly with a .625 diameter shaft, support rail and two single open Simplicity bearings without seals, with a length overall of 73.25", specify part number SRB2-10-073.25.

NOTE: Carry out all fractional lengths to two decimal places.

STANDARD LENGTH TABLE (Inches)

SIZE	AVAILABLE LENGTHS - L* (in inches)																								
08	008	012	016		020	024	028		032	036	040		044	048	052		056	060	064		068	072	076		080
10	008	012	016		020	024	028		032	036	040		044	048	052		056	060	064		068	072	076		080
12		012		018		024		030		036		042		048		054		060		066		072		078	
16		012		018		024		030		036		042		048		054		060		066		072		078	
20		012		018		024		030		036		042		048		054		060		066		072		078	
24			016			024			032		040			048			056		064			072			080
32						024			032		040			048			056		064			072			080

*Non-standard lengths are also available - see non-standard lengths ordering example.

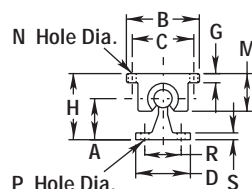
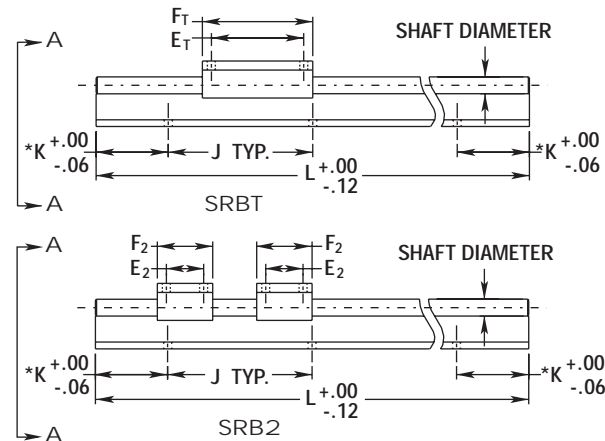

*For standard length dimensions consult chart for "K" dimension.

*For non-standard length dimensions "K" can be calculated with the following formula (in all cases equal on both ends).

$$K(\text{non-std}) = (K(\text{from chart}) - (\Delta L/2)).$$

Where ΔL = next longer standard length - desired length.

NOTES: Longer lengths are available - Consult Factory.

For Full Slide Assemblies, refer to www.pacific-bearing.com

The data and specifications in this publication have been carefully compiled and are believed to be accurate and correct. However, it is the responsibility of the user to determine and ensure the suitability of Pacific Bearing® products for a specific application. Pacific Bearing's only obligation will be to repair or replace without charge, any defective components if returned promptly. No liability is assumed beyond such replacement. *Consult www.pacific-bearing.com for the latest technical updates.

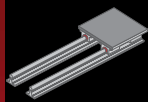

RS - Rail Mounted Slide Assembly

PART NUMBER DIMENSIONS

SERIES		SIZE		L	SHAFT DIA.	W	H	A	B	C	D	E	G	J	R	TAP	HOLE DIA.
RS	X	- 08	- XX	- XXX	.500	6.000	2.188	1.125	2.00	3.500	1.500	.375	5.500	4.000	1.000	10-24	.17
RS	X	- 10	- XX	- XXX	.625	7.000	2.375	1.125	2.50	4.000	1.625	.375	6.312	4.000	1.125	1/4-20	.19
RS	X	- 12	- XX	- XXX	.750	8.000	2.938	1.500	2.75	4.500	1.750	.500	7.125	6.000	1.250	1/4-20	.22
RS	X	- 16	- XX	- XXX	1.000	9.000	3.438	1.750	3.25	5.500	2.125	.500	8.312	6.000	1.500	1/4-20	.28
RS	X	- 20	- XX	- XXX	1.250	11.000	4.375	2.125	4.00	6.500	2.500	.750	10.000	6.000	1.875	5/16-18	.34
RS	X	- 24	- XX	- XXX	1.500	13.000	5.000	2.500	4.75	8.000	3.000	.750	12.000	8.000	2.250	5/16-18	.34
RS	X	- 32	- XX	- XXX	2.000	18.000	6.375	3.250	6.00	10.000	3.750	1.000	15.880	8.000	2.750	3/8-16	.41

- Substitute "L" from standard length table for "XXX"
- *Substitute "00" - Alloy Steel, "SS" - 440 Stainless Steel, or "CR" - Chrome Plated 303 SST for "XX"
- Shaft diameter dimension in 1/16" in increments
- Substitute "X" for "B" - Ball Bearing

Lengths and mounting provisions to your specifications are available - consult factory.

All tabulated dimensions are in inches.

MATERIAL:

Aluminum Alloy - Top Plate, Rail Supports, Pillow Blocks

***Shafting** - Hardened steel alloy, SS 440 stainless steel and CR 303 SST

NOTE: For lengths over 48", guide bars will be continuous, but rail supports will have a minimum of one break every 48".

ORDERING EXAMPLE:

To order a slide with a .625 diameter shaft, and 28" travel, specify part number RS-10-028.

STANDARD LENGTH TABLE (Inches)

SIZE	AVAILABLE LENGTHS - L* (in inches)																													
08	008	012	016		020	024	028		032	036	040		044	048	052		056	060	064		068	072	076		080	084	088		092	096
10	008	012	016		020	024	028		032	036	040		044	048	052		056	060	064		068	072	076		080	084	088		092	096
12		012		018		024		030		036		042		048		054		060		066		072		078		084		090		096
16		012		018		024		030		036		042		048		054		060		066		072		078		084		090		096
20		012		018		024		030		036		042		048		054		060		066		072		078		084		090		096
24			016			024			032		040			048			056		064			072			080		088			096
32						024			032		040			048			056		064			072			080		088			096

*NOTE: Longer lengths are available - consult factory.

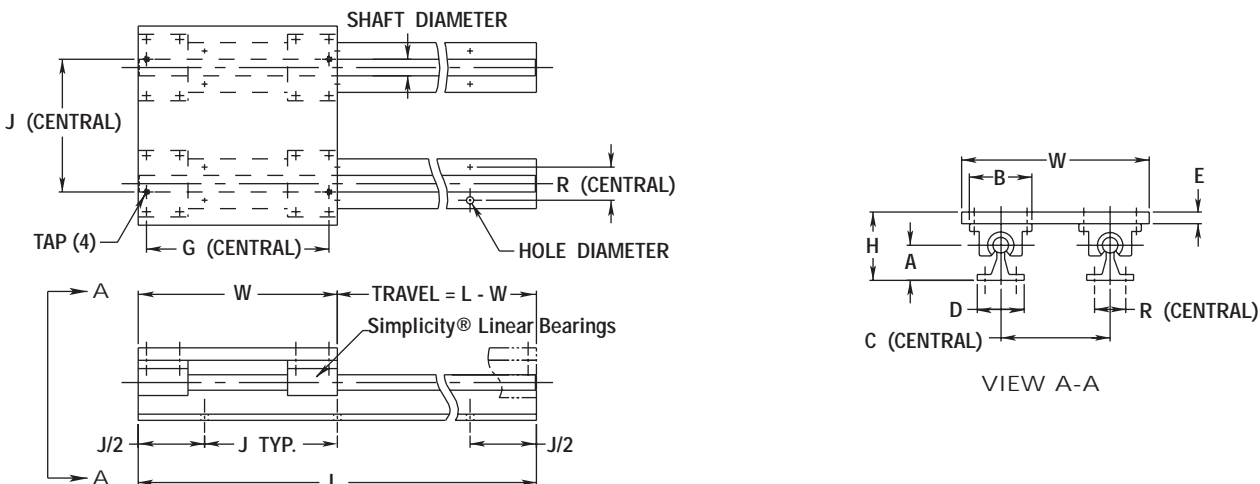

The data and specifications in this publication have been carefully compiled and are believed to be accurate and correct. However, it is the responsibility of the user to determine and ensure the suitability of Pacific Bearing® products for a specific application. Pacific Bearing's only obligation will be to repair or replace without charge, any defective components if returned promptly. No liability is assumed beyond such replacement. *Consult www.pacific-bearing.com for the latest technical updates.

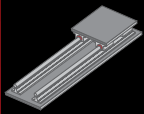

RPS - Rail Mounted & Plate Supported Slide Assembly

PART NUMBER DIMENSIONS

SERIES		SIZE		L	SHAFT DIA.	W	H	A	B	C	D	E	F	G	J	TAP	HOLE
RPS	X	- 08	- XX	- XXX	.500	6.000	2.562	1.125	2.00	3.500	1.500	.375	1.00	5.500	4.000	10-24	.22
RPS	X	- 10	- XX	- XXX	.625	7.000	2.750	1.125	2.50	4.000	1.625	.375	1.00	6.312	4.000	1/4-20	.28
RPS	X	- 12	- XX	- XXX	.750	8.000	3.438	1.500	2.75	4.500	1.750	.500	1.25	7.125	6.000	1/4-20	.28
RPS	X	- 16	- XX	- XXX	1.000	9.000	3.938	1.750	3.25	5.500	2.125	.500	1.25	8.312	6.000	1/4-20	.28
RPS	X	- 20	- XX	- XXX	1.250	11.000	5.125	2.125	4.00	6.500	2.500	.750	1.50	10.000	6.000	5/16-18	.34
RPS	X	- 24	- XX	- XXX	1.500	13.000	5.750	2.500	4.75	8.000	3.000	.750	1.50	12.000	8.000	5/16-18	.34
RPS	X	- 32	- XX	- XXX	2.000	18.000	7.375	3.250	6.00	10.000	3.750	1.000	1.75	15.875	8.000	3/8-16	.41

- ... Substitute "L" from standard length table for "XXX"
- ... Substitute "00"- Alloy Steel, "SS" - 440 Stainless Steel, or "CR" - Chrome Plated 303 SST for "XX"
- ... Shaft diameter dimension in 1/16" increments
- ... Substitute "X" for "B" - Ball Bearing

Lengths and mounting provisions to your specifications are available - consult factory.

All tabulated dimensions are in inches.

MATERIAL:

Aluminum Alloy - Top Plate, Bottom Plate, Rail Supports, Pillow Blocks.

Steel Alloy - Shafts with proprietary low friction corrosion resistant surface treatment.

ORDERING EXAMPLE:

To order a slide with a .625 diameter shaft, and 28" travel, specify part number RPS-10-028.

STANDARD LENGTH TABLE (Inches)

SIZE	AVAILABLE LENGTHS - L* (in inches)																													
08	008	012	016		020	024	028		032	036	040		044	048	052		056	060	064		068	072	076		080	084	088		092	096
10	008	012	016		020	024	028		032	036	040		044	048	052		056	060	064		068	072	076		080	084	088		092	096
12		012		018		024		030		036		042		048		054		060		066		072		078		084		090		096
16		012		018		024		030		036		042		048		054		060		066		072		078		084		090		096
20		012		018		024		030		036		042		048		054		060		066		072		078		084		090		096
24			016			024			032		040			048			056		064			072			080		088			096
32						024			032		040			048			056		064			072			080		088			096

*NOTE: Longer lengths are available - consult factory.

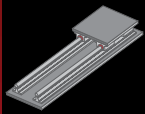

RPS - Rail Mounted & Plate Supported Slide Assembly

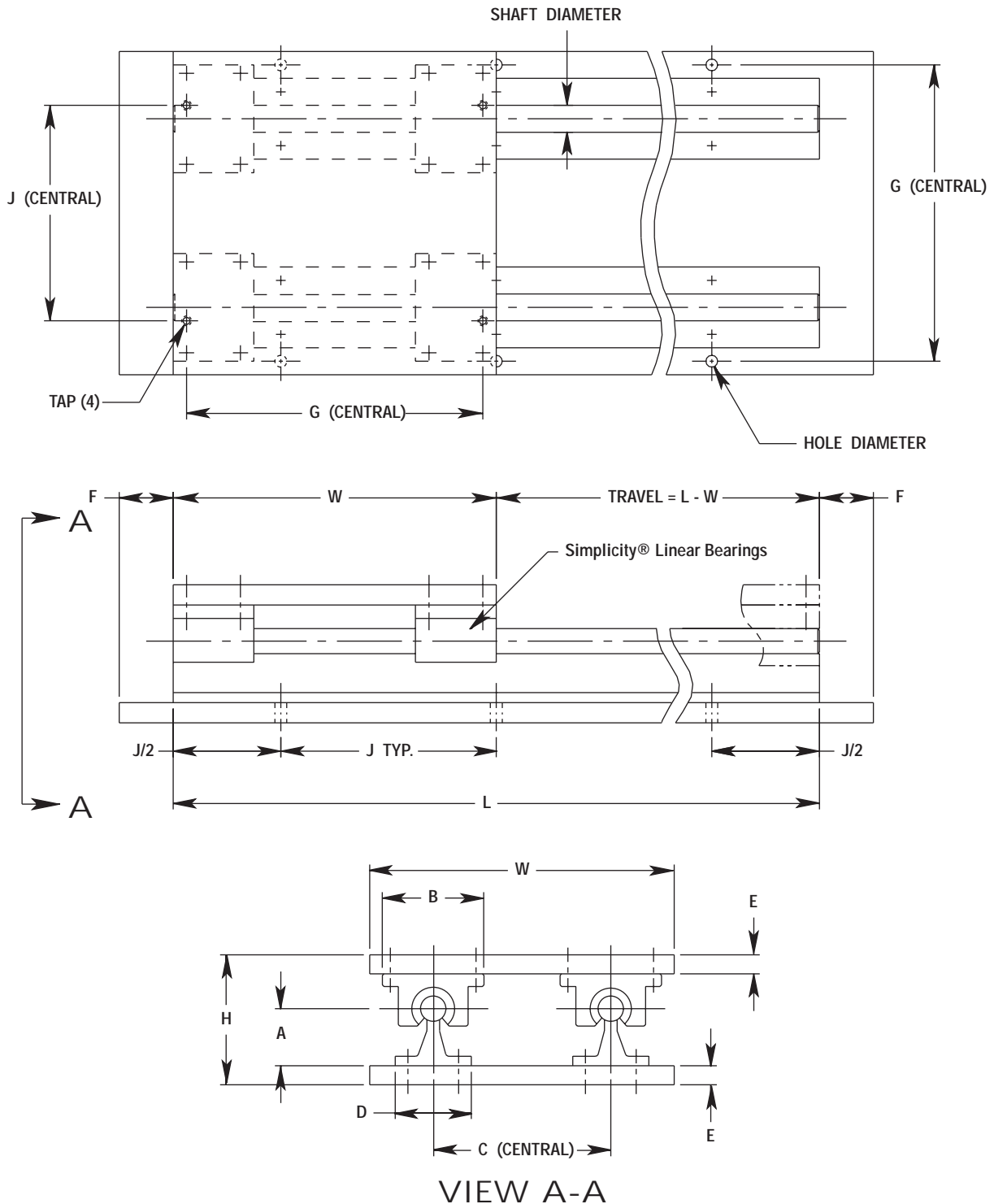

RPS

The data and specifications in this publication have been carefully compiled and are believed to be accurate and correct. However, it is the responsibility of the user to determine and ensure the suitability of Pacific Bearing® products for a specific application. Pacific Bearing's only obligation will be to repair or replace without charge, any defective components if returned promptly. No liability is assumed beyond such replacement. *Consult www.pacific-bearing.com for the latest technical updates.

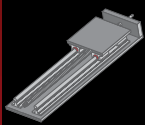

Simplicity® Linear Slides

Inch Series - 1RPS

Linear Motion Systems

1 RPS - Rail Mounted & Plate Supported Ball Screw Driven Slide Assembly (Supported on one end)

DIMENSIONAL INFORMATION

SHAFT DIA.	W	H	A	B	C	D	E	F	G	J	K	M	N	O	TAP	HOLE	KEY
.500	6.000	2.562	1.125	2.00	3.500	1.500	.375	1.00	5.500	4.000	1.375	.375	1.45	.63	10-24	.22	3/32 sq X 5/8 lg
.625	7.000	2.750	1.125	2.50	4.000	1.625	.375	1.00	6.312	4.000	1.375	.375	1.45	.63	1/4-20	.28	3/32 sq X 5/8 lg
.750	8.000	3.438	1.500	2.75	4.500	1.750	.500	1.25	7.125	6.000	1.500	.375	1.45	.63	1/4-20	.28	3/32 sq X 5/8 lg
1.000	9.000	3.938	1.750	3.25	5.500	2.125	.500	1.25	8.312	6.000	2.125	.625	1.76	1.00	1/4-20	.28	3/16 sq X 1" lg
1.250	11.000	5.125	2.125	4.00	6.500	2.500	.750	1.50	10.000	6.000	2.375	.625	1.76	1.00	5/16-18	.34	3/16 sq X 1" lg
1.500	13.000	5.750	2.500	4.75	8.000	3.000	.750	1.50	12.000	8.000	2.875	1.000	2.31	1.50	5/16-18	.34	1/4 sq X 1.62 lg
2.000	18.000	7.375	3.250	6.00	10.000	3.750	1.000	1.75	15.875	8.000	3.875	1.000	2.31	1.50	3/8-16	.41	1/4 sq X 1.62 lg

PART NUMBER

SERIES		SIZE		L		LEAD	
1RPS	X	-	08	-	XXX	-	YYY
1RPS	X	-	10	-	XXX	-	YYY
1RPS	X	-	12	-	XXX	-	YYY
1RPS	X	-	16	-	XXX	-	YYY
1RPS	X	-	20	-	XXX	-	YYY
1RPS	X	-	24	-	XXX	-	YYY
1RPS	X	-	32	-	XXX	-	YYY

MATERIAL:

Aluminum Alloy - Top Plate, Bottom Plate, Rail Supports, Pillow Blocks.

Alloy Steel - Shafting with proprietary low friction corrosion resistant surface treatment.

ORDERING EXAMPLE:

To order a slide with a \emptyset .625 diameter shaft, 21.00" travel, .200" right hand select ball screw, specify part number 1RPS-10-028-AR1.

- ↑ Shaft diameter dimension in 1/16" increments
- ↑ Substitute "X" for "B" - Ball Bearing
- ↑ Substitute "L" from standard length table for "XXX"
- ↑ Substitute standard or select lead code from table for "YYY"

STANDARD LEAD TABLE

SIZE	AVAILABLE LEAD CODES						LEAD CODES		
08	ARO	ALO					ARO = .200 Right Hand		
10	ARO	ALO					ALO = .200 Left Hand		
12	ARO	ALO					BRO = .250 Right Hand		
16			BRO	BLO	CRO	DRO	BLO = .250 Left Hand		
20			BRO	BLO	CRO	DRO	CRO = .500 Right Hand		
24			BRO	BLO	CRO	DRO	DLO	ERO	DRO = 1.000 Right Hand
32			BRO	BLO	CRO	DRO	DLO	ERO	DLO = 1.000 Left Hand
									ERO = 1.875 Right Hand

NOTE: Standard leads are accurate to less than .007" per foot accumulative.

SELECT LEAD TABLE

SIZE	AVAILABLE LEAD CODES						LEAD CODES		
08	AR1	AL1					AR1 = .200 Right Hand		
10	AR1	AL1					AL1 = .200 Left Hand		
12	AR1	AL1					BR1 = .250 Right Hand		
16			BR1	BL1	CR1	DR1	BL1 = .250 Left Hand		
20			BR1	BL1	CR1	DR1	CR1 = .500 Right Hand		
24			BR1	BL1	CR1	DR1	DL1	ER1	DR1 = 1.000 Right Hand
32			BR1	BL1	CR1	DR1	DL1	ER1	DL1 = 1.000 Left Hand
									ER1 = 1.875 Right Hand

NOTE: Select leads are accurate to less than .003" per foot accumulative.

STANDARD LENGTH TABLE (Inches)

SIZE	AVAILABLE LENGTHS - L* (in inches)															
08	008	012	016		020	024	028		032							
10	008	012	016		020	024	028		032							
12		012		018		024		030		036		042				
16		012		018		024		030		036		042				
20		012		018		024		030		036		042		048		
24			016			024			032		040			048		
32						024			032		040			048		

*NOTE: Longer lengths are available - consult factory.

The data and specifications in this publication have been carefully compiled and are believed to be accurate and correct. However, it is the responsibility of the user to determine and ensure the suitability of Pacific Bearing® products for a specific application. Pacific Bearing's only obligation will be to repair or replace without charge, any defective components if returned promptly. No liability is assumed beyond such replacement. *Consult www.pacific-bearing.com for the latest technical updates.

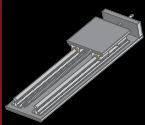

1 RPS - Rail Mounted & Plate Supported Ball Screw Driven Slide Assembly (Supported on one end)

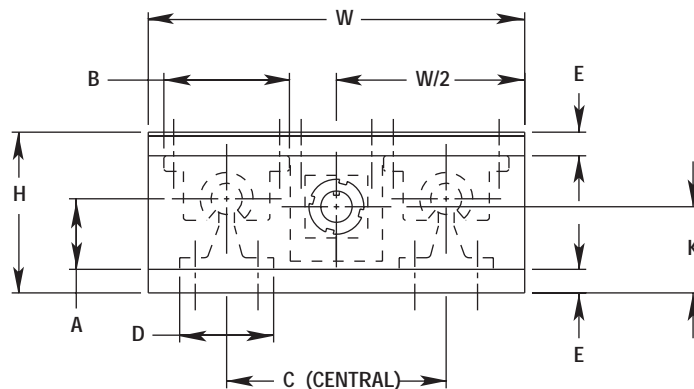
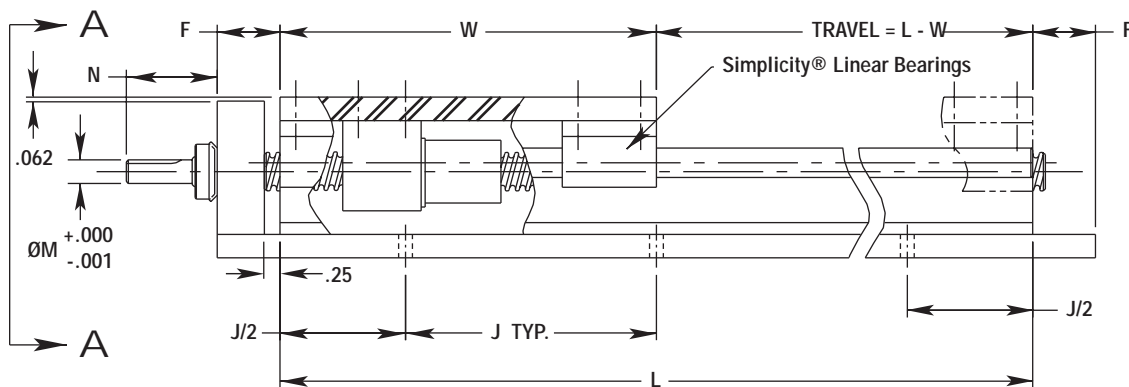
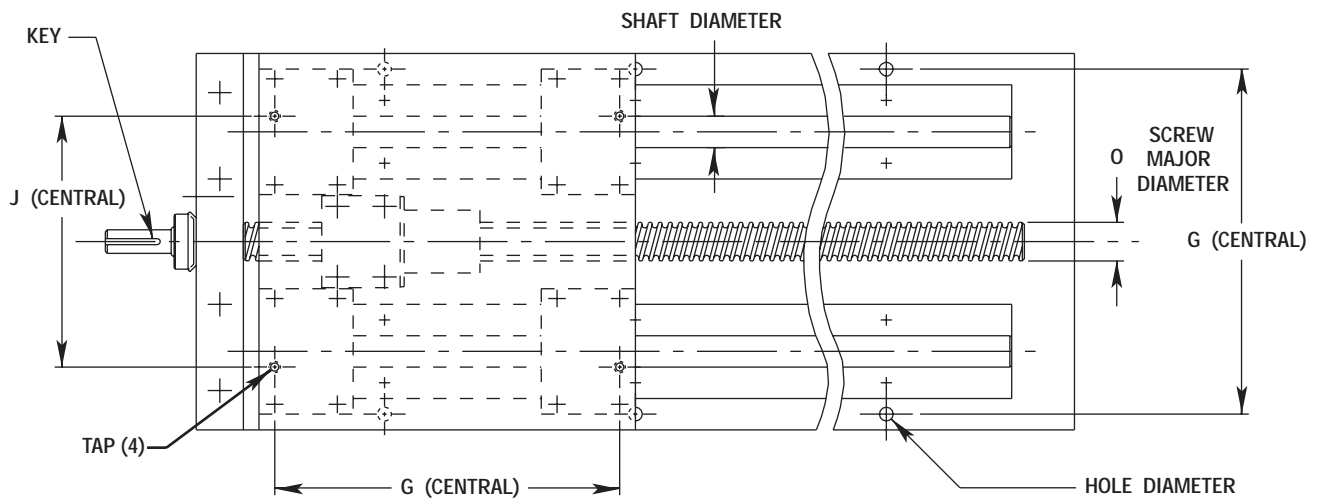

VIEW A-A

The data and specifications in this publication have been carefully compiled and are believed to be accurate and correct. However, it is the responsibility of the user to determine and ensure the suitability of Pacific Bearing® products for a specific application. Pacific Bearing's only obligation will be to repair or replace without charge, any defective components if returned promptly. No liability is assumed beyond such replacement. *Consult www.pacific-bearing.com for the latest technical updates.

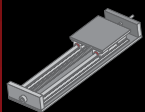

Simplicity® Linear Slides

Inch Series - 2RPS

2RPS - Rail Mounted & Plate Supported Ball Screw Driven Slide Assembly (Supported on one end)

DIMENSIONAL INFORMATION

SHAFT DIA.	HOLE W	H	A	B	C	D	E	F	G	J	K	M	N	O	TAP	DIA.	KEY
.500	6.000	2.562	1.125	2.00	3.500	1.500	.375	1.00	5.500	4.000	1.375	.375	1.45	.63	10-24	.22	3/32 sq X 5/8 lg
.625	7.000	2.750	1.125	2.50	4.000	1.625	.375	1.00	6.312	4.000	1.375	.375	1.45	.63	1/4-20	.28	3/32 sq X 5/8 lg
.750	8.000	3.438	1.500	2.75	4.500	1.750	.500	1.25	7.125	6.000	1.500	.375	1.45	.63	1/4-20	.28	3/32 sq X 5/8 lg
1.000	9.000	3.938	1.750	3.25	5.500	2.125	.500	1.25	8.312	6.000	2.125	.625	1.76	1.00	1/4-20	.28	3/16 sq X 1" lg
1.250	11.000	5.125	2.125	4.00	6.500	2.500	.750	1.50	10.000	6.000	2.375	.625	1.76	1.00	5/16-18	.34	3/16 sq X 1" lg
1.500	13.000	5.750	2.500	4.75	8.000	3.000	.750	1.50	12.000	8.000	2.875	1.000	2.31	1.50	5/16-18	.34	1/4 sq X 1.62 lg
2.000	18.000	7.375	3.250	6.00	10.000	3.750	1.000	1.75	15.875	8.000	3.875	1.000	2.31	1.50	3/8-16	.41	1/4 sq X 1.62 lg

PART NUMBER

SERIES		SIZE		L	LEAD
2RPS	X	- 08	- XX	- XXX	- YYY
2RPS	X	- 10	- XX	- XXX	- YYY
2RPS	X	- 12	- XX	- XXX	- YYY
2RPS	X	- 16	- XX	- XXX	- YYY
2RPS	X	- 20	- XX	- XXX	- YYY
2RPS	X	- 24	- XX	- XXX	- YYY
2RPS	X	- 32	- XX	- XXX	- YYY

MATERIAL:

Aluminum Alloy - Top Plate, Bottom Plate, Rail Supports, Pillow Blocks.

Alloy Steel - Shafting with proprietary low friction corrosion resistant surface treatment.

ORDERING EXAMPLE:

To order a slide with a Ø.625 diameter shaft, 21.00" travel, .200" right hand select ball screw - specify part number, 2RPS-10-028-AR1.

- Substitute standard or select lead code from table for "YYY"
- Substitute "L" from standard length table for "XXX"
- Substitute "00"- Alloy Steel, "SS"- 440 Stainless Steel, "CR"- Chrome Plated 303 SST for "XX"
- Shaft diameter dimension in 1/16" increments
- Substitute "X" for "B" - Ball Bearing

STANDARD LEAD TABLE

SIZE	AVAILABLE LEAD CODES							LEAD CODES	
08	ARO	ALO						ARO = .200 Right Hand	
10	ARO	ALO						ALO = .200 Left Hand	
12	ARO	ALO						BRO = .250 Right Hand	
16			BRO	BLO	CRO	DRO		BLO = .250 Left Hand	
20			BRO	BLO	CRO	DRO		CRO = .500 Right Hand	
24			BRO	BLO	CRO	DRO	DLO	ERO	DRO = 1.000 Right Hand
32			BRO	BLO	CRO	DRO	DLO	ERO	DLO = 1.000 Left Hand
									ERO = 1.875 Right Hand

NOTE: Standard leads are accurate to less than .007" per foot accumulative.

SELECT LEAD TABLE

SIZE	AVAILABLE LEAD CODES							LEAD CODES	
08	AR1	AL1						AR1 = .200 Right Hand	
10	AR1	AL1						AL1 = .200 Left Hand	
12	AR1	AL1						BR1 = .250 Right Hand	
16			BR1	BL1	CR1	DR1		BL1 = .250 Left Hand	
20			BR1	BL1	CR1	DR1		CR1 = .500 Right Hand	
24			BR1	BL1	CR1	DR1	DL1	ER1	DR1 = 1.000 Right Hand
32			BR1	BL1	CR1	DR1	DL1	ER1	DL1 = 1.000 Left Hand
									ER1 = 1.875 Right Hand

NOTE: Select leads are accurate to less than .003" per foot accumulative.

STANDARD LENGTH TABLE (Inches)

SIZE	AVAILABLE LENGTHS - L* (in inches)																													
08	008	012	016		020	024	028		032	036	040		044	048	052		056	060	064		068	072	076		080	084	088		092	096
10	008	012	016		020	024	028		032	036	040		044	048	052		056	060	064		068	072	076		080	084	088		092	096
12		012		018		024		030		036		042		048		054		060		066		072		078		084		090		096
16		012		018		024		030		036		042		048		054		060		066		072		078		084		090		096
20		012		018		024		030		036		042		048		054		060		066		072		078		084		090		096
24			016			024			032		040			048			056		064			072			080		088			096
32						024			032		040			048			056		064			072			080		088			096

*NOTE: Longer lengths are available - consult factory.

The data and specifications in this publication have been carefully compiled and are believed to be accurate and correct. However, it is the responsibility of the user to determine and ensure the suitability of Pacific Bearing® products for a specific application. Pacific Bearing's only obligation will be to repair or replace without charge, any defective components if returned promptly. No liability is assumed beyond such replacement. *Consult www.pacific-bearing.com for the latest technical updates.

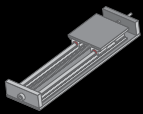

2RPS - Rail Mounted & Plate Supported Ball Screw Driven Slide Assembly (Supported on one end)

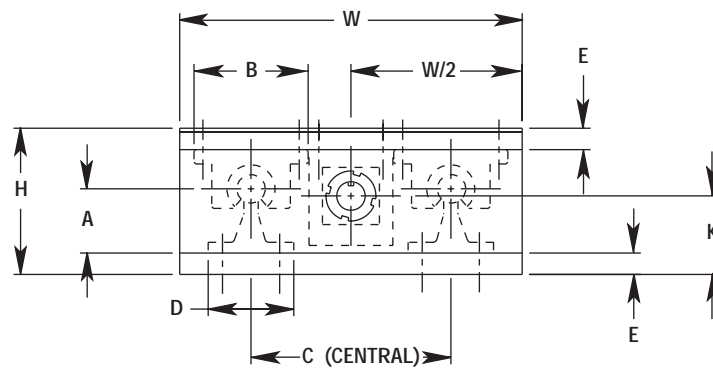
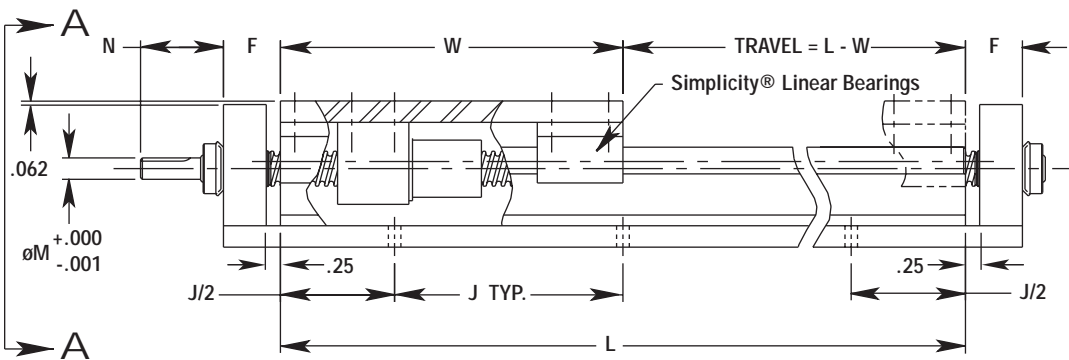
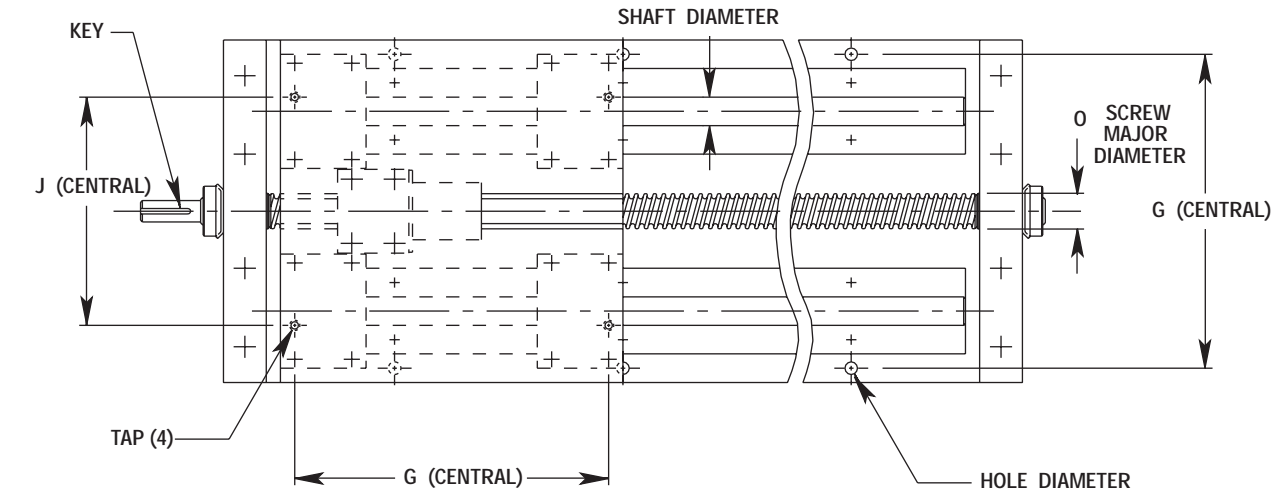

VIEW A-A

The data and specifications in this publication have been carefully compiled and are believed to be accurate and correct. However, it is the responsibility of the user to determine and ensure the suitability of Pacific Bearing® products for a specific application. Pacific Bearing's only obligation will be to repair or replace without charge, any defective components if returned promptly. No liability is assumed beyond such replacement. *Consult www.pacific-bearing.com for the latest technical updates.

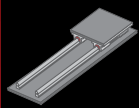

LRPS - Low Profile Rail Mounted & Plate Supported Slide Assembly

PART NUMBER

DIMENSIONS

SERIES		SIZE		L	SHAFT DIA.	W	H	A	B	C	D	E	F	G	J	TAP	HOLE DIA.
LRPS	X	- 08	- XX	- XXX	.500	6.000	2.000	.563	2.00	3.500	.37	.375	1.00	5.500	4.000	10-24	.22
LRPS	X	- 10	- XX	- XXX	.625	7.000	2.313	.688	2.50	4.000	.45	.375	1.00	6.312	4.000	1/4-20	.28
LRPS	X	- 12	- XX	- XXX	.750	8.000	2.688	.750	2.75	4.500	.51	.500	1.25	7.125	6.000	1/4-20	.28
LRPS	X	- 16	- XX	- XXX	1.000	9.000	3.188	1.000	3.25	5.500	.69	.500	1.25	8.312	6.000	1/4-20	.28
LRPS	X	- 20	- XX	- XXX	1.250	11.000	4.188	1.188	4.00	6.500	.78	.750	1.50	10.000	6.000	5/16-18	.34
LRPS	X	- 24	- XX	- XXX	1.500	13.000	4.625	1.375	4.75	8.000	.93	.750	1.50	12.000	8.000	5/16-18	.34
LRPS	X	- 32	- XX	- XXX	2.000	18.000	5.875	1.750	6.00	10.000	1.18	1.000	1.75	15.875	8.000	3/8-16	.41

- ↑ Substitute "L" from standard length table for "XXX"
- ↑ Substitute "00"- Alloy Steel, "SS" - 440 Stainless Steel, or "CR"- Chrome Plated 303 SST for "XX"
- ↑ Shaft diameter dimension in 1/16" increments
- ↑ Substitute "X" for "B" - Ball Bearing

Lengths and mounting provisions to your specifications are available - consult factory.

All tabulated dimensions are in inches.

MATERIAL:

Aluminum Alloy - Top Plate, Bottom Plate, Rail Supports, Pillow Blocks.

Steel Alloy - Shafting with proprietary low friction corrosion resistant surface treatment.

ORDERING EXAMPLE:

To order a slide with a .625 diameter shaft, and 28" travel, specify part number LRPS-10-028.

STANDARD LENGTH TABLE (Inches)

SIZE	AVAILABLE LENGTHS - L* (in inches)																													
08	008	012	016		020	024	028		032	036	040		044	048	052		056	060	064		068	072	076		080	084	088		092	096
10	008	012	016		020	024	028		032	036	040		044	048	052		056	060	064		068	072	076		080	084	088		092	096
12		012		018		024		030		036		042		048		054		060		066		072		078		084		090		096
16		012		018		024		030		036		042		048		054		060		066		072		078		084		090		096
20		012		018		024		030		036		042		048		054		060		066		072		078		084		090		096
24			016			024			032		040			048			056		064			072			080		088			096
32						024			032		040			048			056		064			072			080		088			096

*NOTE: Longer lengths are available - consult factory.

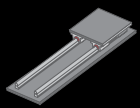

LRPS - Low Profile Rail Mounted & Plate Supported Slide Assembly

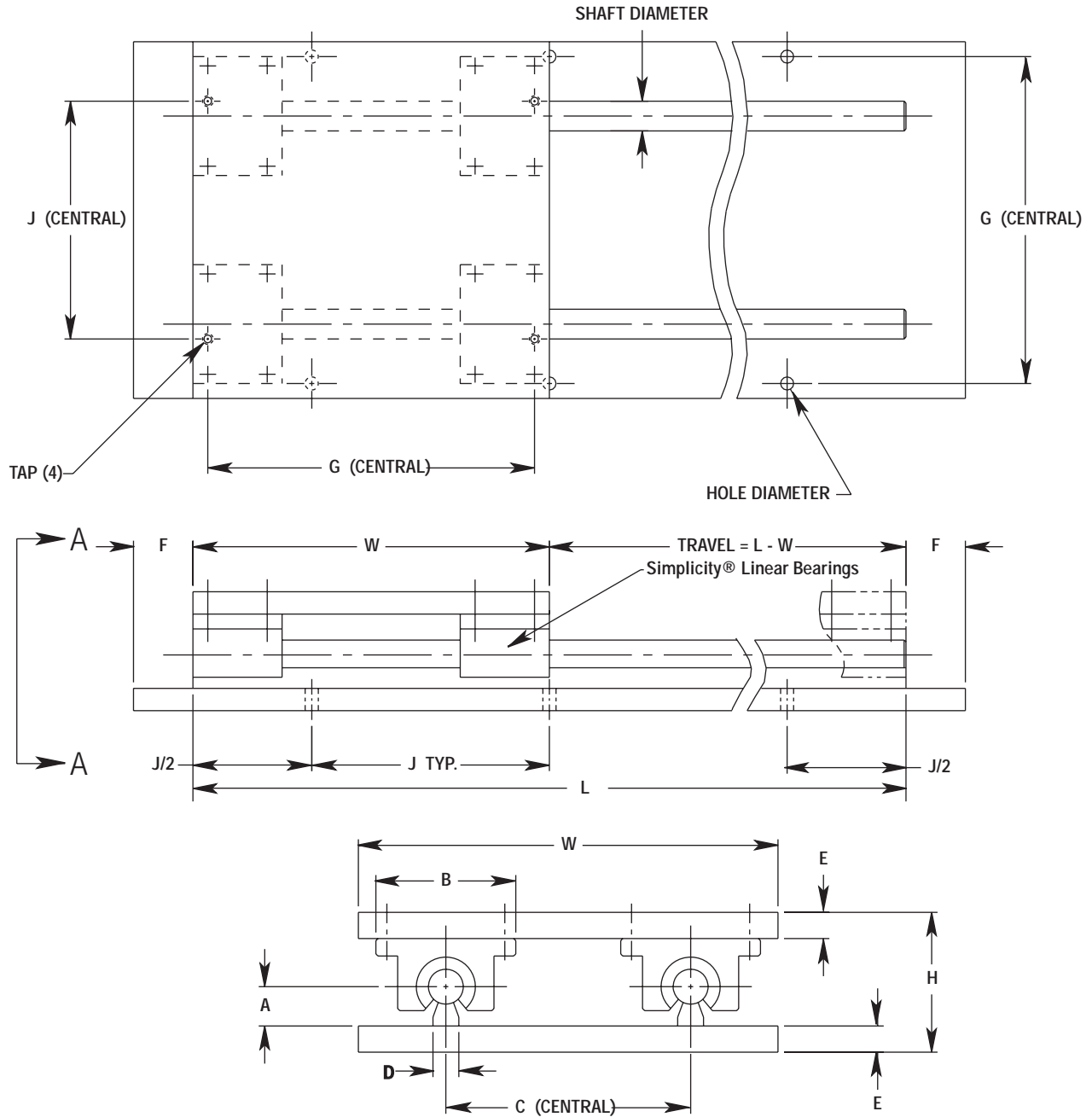

VIEW A-A

The data and specifications in this publication have been carefully compiled and are believed to be accurate and correct. However, it is the responsibility of the user to determine and ensure the suitability of Pacific Bearing® products for a specific application. Pacific Bearing's only obligation will be to repair or replace without charge, any defective components if returned promptly. No liability is assumed beyond such replacement. *Consult www.pacific-bearing.com for the latest technical updates.

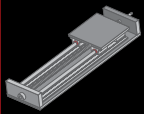

2LRPS - Low Profile Rail Mounted & Plate Supported Ball Screw Driven Slide Assembly (Supported on Both Ends)

DIMENSIONAL INFORMATION

SHAFT DIA.	HOLE W	H	A	B	C	D	E	F	G	J	K	M	N	O	P	TAP	DIA.	KEY
0.500	6.0	2.000	0.563	2.00	3.5	0.37	0.375	1.00	5.50	4.0	1.000	0.38	1.45	0.63	0.031	10-24	.22	3/32 sq X 5/8 lg
0.625	7.0	2.313	0.688	2.50	4.0	0.45	0.375	1.00	6.31	4.0	1.156	0.38	1.45	0.63	0.031	1/4-20	.28	3/32 sq X 5/8 lg
0.750	8.0	2.688	0.750	2.75	4.5	0.51	0.500	1.25	7.13	6.0	1.344	0.38	1.45	0.63	0.031	1/4-20	.28	3/32 sq X 5/8 lg
1.000	9.0	3.188	1.000	3.25	5.5	0.69	0.500	1.25	8.31	6.0	1.594	0.63	1.76	1.00	0.062	1/4-20	.28	3/16 sq X 1" lg
1.250	11.0	4.188	1.188	4.00	6.5	0.78	0.750	1.50	10.00	6.0	2.094	0.63	1.76	1.00	0.062	5/16-18	.34	3/16 sq X 1" lg
1.500	13.0	4.625	1.375	4.75	8.0	0.93	0.750	1.50	12.00	8.0	2.312	1.00	2.31	1.50	0.062	5/16-18	.34	1/4 sq X 1.62 lg
2.000	18.0	5.875	1.750	6.00	10.0	1.18	1.000	1.75	15.88	8.0	2.937	1.00	2.31	1.50	0.062	3/8-16	.41	1/4 sq X 1.62 lg

PART NUMBER

SERIES		SIZE		L	LEAD
2LRPS	X	08	XX	XXX	YYY
2LRPS	X	10	XX	XXX	YYY
2LRPS	X	12	XX	XXX	YYY
2LRPS	X	16	XX	XXX	YYY
2LRPS	X	20	XX	XXX	YYY
2LRPS	X	24	XX	XXX	YYY
2LRPS	X	32	XX	XXX	YYY

MATERIAL:

Aluminum Alloy - Top Plate, Bottom Plate, Rail Supports, Pillow Blocks.

Alloy Steel - Shafting with proprietary low friction corrosion resistant surface treatment.

ORDERING EXAMPLE:

To order a slide with a Ø.625 diameter shaft, 28" travel, .200" right hand select ball screw - specify part number, 2LRPS-10-028-AR1.

Substitute standard or select lead code from table for "YYY"

Substitute "L" from standard length table for "XXX"

Substitute "00" - Alloy Steel, "SS" - 440 Stainless Steel, or "CR" - Chrome Plated 303 SST for "XX"

Shaft diameter dimension in 1/16" increments

Substitute "X" for "B" - Ball Bearing

STANDARD LEAD TABLE

SIZE	AVAILABLE LEAD CODES						LEAD CODES
08	ARO	ALO					ARO = .200 Right Hand
10	ARO	ALO					ALO = .200 Left Hand
12	ARO	ALO					BRO = .250 Right Hand
16			BRO	BLO	CRO	DRO	BLO = .250 Left Hand
20			BRO	BLO	CRO	DRO	CRO = .500 Right Hand
24			BRO	BLO	CRO	DRO	DRO = 1.000 Right Hand
32			BRO	BLO	CRO	DRO	DLO = 1.000 Left Hand
							ERO = 1.875 Right Hand

NOTE: Standard leads are accurate to less than .007" per foot accumulative.

SELECT LEAD TABLE

SIZE	AVAILABLE LEAD CODES						LEAD CODES
08	AR1	AL1					AR1 = .200 Right Hand
10	AR1	AL1					AL1 = .200 Left Hand
12	AR1	AL1					BR1 = .250 Right Hand
16			BR1	BL1	CR1	DR1	BL1 = .250 Left Hand
20			BR1	BL1	CR1	DR1	CR1 = .500 Right Hand
24			BR1	BL1	CR1	DR1	DL1 = 1.000 Right Hand
32			BR1	BL1	CR1	DR1	DL1 = 1.000 Left Hand
							ER1 = 1.875 Right Hand

NOTE: Select leads are accurate to less than .003" per foot accumulative.

STANDARD LENGTH TABLE (Inches)

SIZE	AVAILABLE LENGTHS - L* (in inches)																													
08	008	012	016		020	024	028		032	036	040		044	048	052		056	060	064		068	072	076		080	084	088		092	096
10	008	012	016		020	024	028		032	036	040		044	048	052		056	060	064		068	072	076		080	084	088		092	096
12		012		018		024		030		036		042		048		054		060		066		072		078		084		090		096
16		012		018		024		030		036		042		048		054		060		066		072		078		084		090		096
20		012		018		024		030		036		042		048		054		060		066		072		078		084		090		096
24			016			024			032		040			048			056		064			072			080		088		096	
32						024			032		040			048			056		064			072			080		088		096	

* Longer lengths are available - consult factory.

The data and specifications in this publication have been carefully compiled and are believed to be accurate and correct. However, it is the responsibility of the user to determine and ensure the suitability of Pacific Bearing® products for a specific application. Pacific Bearing's only obligation will be to repair or replace without charge, any defective components if returned promptly. No liability is assumed beyond such replacement. *Consult www.pacific-bearing.com for the latest technical updates.

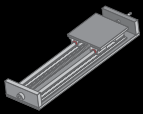

2LRPS - Low Profile Rail Mounted & Plate Supported Ball Screw Driven Slide Assembly (Supported on Both Ends)

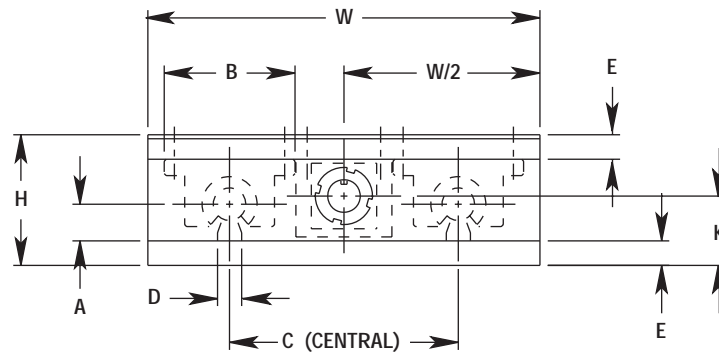
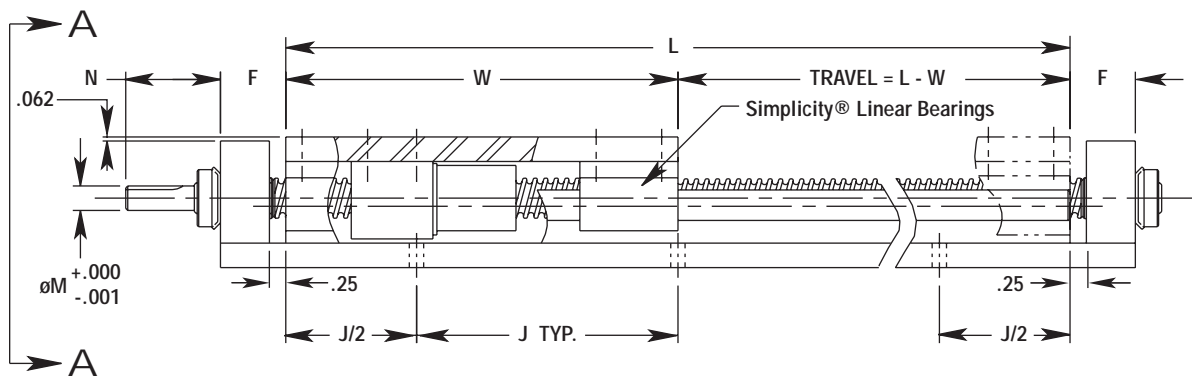
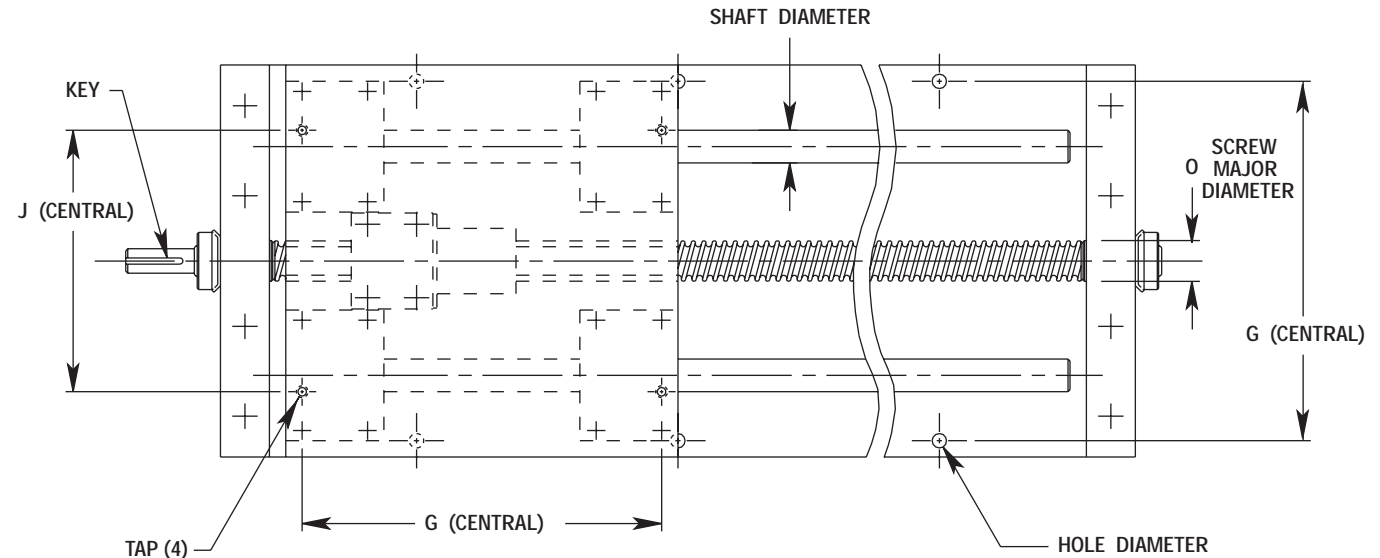

VIEW A-A

The data and specifications in this publication have been carefully compiled and are believed to be accurate and correct. However, it is the responsibility of the user to determine and ensure the suitability of Pacific Bearing® products for a specific application. Pacific Bearing's only obligation will be to repair or replace without charge, any defective components if returned promptly. No liability is assumed beyond such replacement. *Consult www.pacific-bearing.com for the latest technical updates.

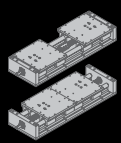

SC2RPS - Self-Centering Slide Assembly

DIMENSIONAL INFORMATION

SHAFT DIA.	W	H	A	B	C	D	E	F	G	J	K	M	N	O	TAP	HOLE	KEY
.500	6.000	2.562	1.125	2.00	3.500	1.500	.375	1.00	5.500	4.000	1.375	.375	1.45	.63	10-24	.22	3/32 sq X 5/8 lg
.625	7.000	2.750	1.125	2.50	4.000	1.625	.375	1.00	6.312	4.000	1.375	.375	1.45	.63	1/4-20	.28	3/32 sq X 5/8 lg
.750	8.000	3.438	1.500	2.75	4.500	1.750	.500	1.25	7.125	6.000	1.500	.375	1.45	.63	1/4-20	.28	3/32 sq X 5/8 lg
1.000	9.000	3.938	1.750	3.25	5.500	2.125	.500	1.25	8.312	6.000	2.125	.625	1.76	1.00	1/4-20	.28	3/16 sq X 1" lg
1.250	11.000	5.125	2.125	4.00	6.500	2.500	.750	1.50	10.000	6.000	2.375	.625	1.76	1.00	5/16-18	.34	3/16 sq X 1" lg
1.500	13.000	5.750	2.500	4.75	8.000	3.000	.750	1.50	12.000	8.000	2.875	1.000	2.31	1.50	5/16-18	.34	1/4 sq X 1.62 lg
2.000	18.000	7.375	3.250	6.00	10.000	3.750	1.000	1.75	15.875	8.000	3.875	1.000	2.31	1.50	3/8-16	.41	1/4 sq X 1.62 lg

PART NUMBER

SERIES		SIZE		L	LEAD
SC2RPS	X	- 08	- XX	- XXX	- XXX
SC2RPS	X	- 10	- XX	- XXX	- XXX
SC2RPS	X	- 12	- XX	- XXX	- XXX
SC2RPS	X	- 16	- XX	- XXX	- XXX
SC2RPS	X	- 20	- XX	- XXX	- XXX
SC2RPS	X	- 24	- XX	- XXX	- XXX
SC2RPS	X	- 32	- XX	- XXX	- XXX

MATERIAL:

Aluminum Alloy - Top and bottom plates, rail supports, and pillow blocks.

Alloy Steel - Shafting with proprietary low friction corrosion resistant surface treatment. Rolled ball screw, ball nut assembly, and rigid coupling.

Substitute "00" - Alloy Steel, "SS" - 440 Stainless Steel, or "CR" - Chrome Plated 303 SST for "XX"

Substitute "X" for "B" - Ball Bearing

ORDERING EXAMPLE: SC2RPS-10-056-ALR1

Shaft diameter in 1/16" increments (10/16 = .625")

STANDARD & SELECT - BALL SCREW LEAD CODE TABLE

SIZE	AVAILABLE LEAD CODE			LEAD CODES
08	ALR?			ALR? = .200 Leads
10	ALR?			BLR? = .250 Leads
12	ALR?			DLR? = 1.000 Leads
16		BLR?		One left and one right hand lead ballscrew on each self-centering slide assembly.
20		BLR?		
24		BLR?	DLR?	
32		BLR?	DLR?	

Replace ? with 0 for standard lead accurate to less than .007" per foot accumulative

Replace ? with 1 for standard lead accurate to less than .003" per foot accumulative

STANDARD LENGTH TABLE (Inches)

SIZES	AVAILABLE LENGTHS - L* (in inches)																				
08	016	020	024	028	032	036	040	044	048	052	056	060	064	068	072	076	080	084	088	092	096
10	016	020	024	028	032	036	040	044	048	052	056	060	064	068	072	076	080	084	088	092	096
12		018	024	030	036	042	048	054	060	066	072	078	084	090	096						
16			024	030	036	042	048	054	060	066	072	078	084	090	096						
20			024	030	036	042	048	054	060	066	072	078	084	090	096						
24					032	040	048	056	064	072	080	088	096								
32						040	048	056	064	072	080	088	096								

*NOTE: Longer lengths are available - consult factory.

The data and specifications in this publication have been carefully compiled and are believed to be accurate and correct. However, it is the responsibility of the user to determine and ensure the suitability of Pacific Bearing® products for a specific application. Pacific Bearing's only obligation will be to repair or replace without charge, any defective components if returned promptly. No liability is assumed beyond such replacement. *Consult www.pacific-bearing.com for the latest technical updates.

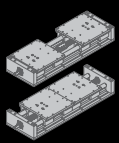

SC2RPS - Self-Centering Slide Assembly

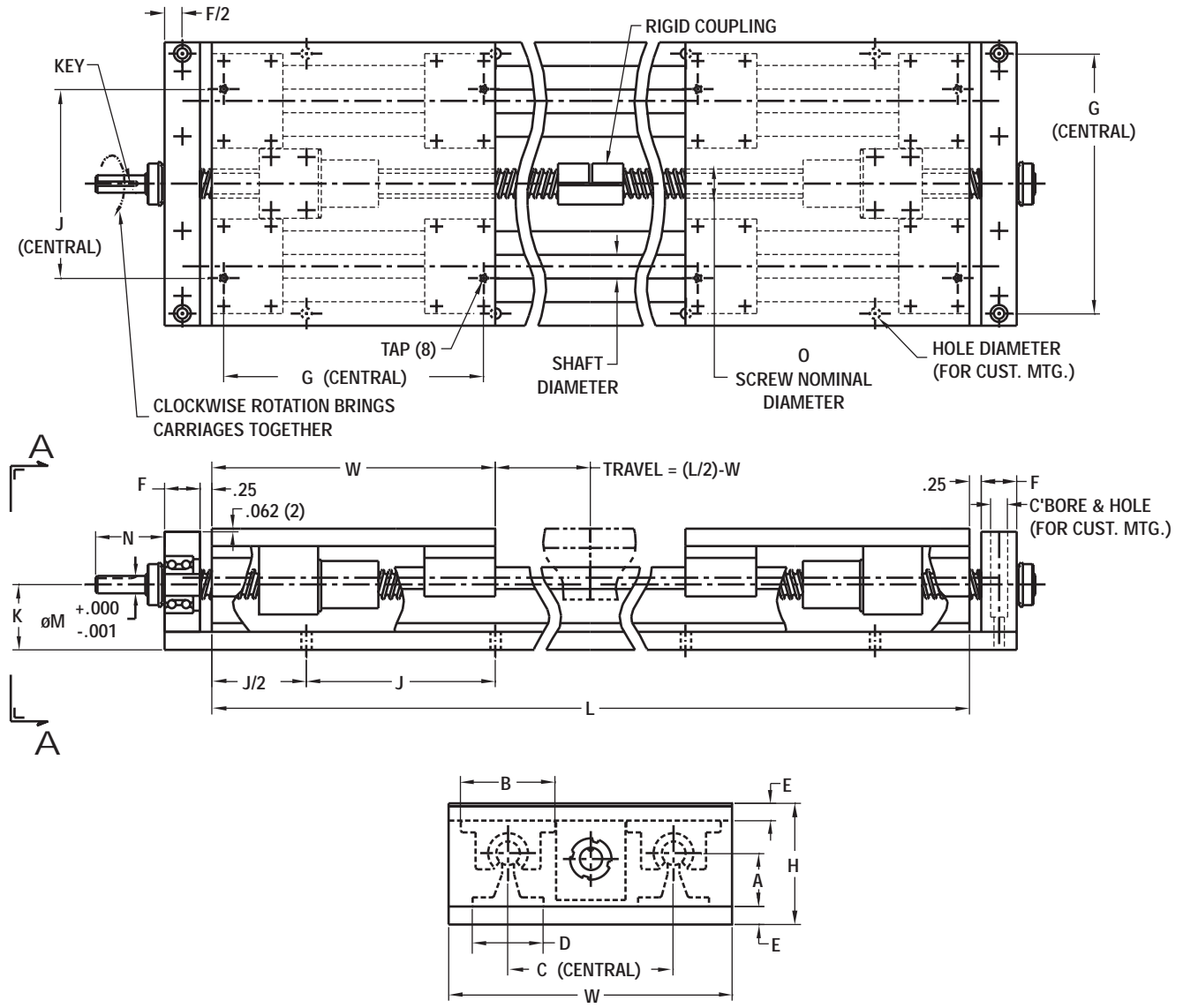

VIEW A-A

The data and specifications in this publication have been carefully compiled and are believed to be accurate and correct. However, it is the responsibility of the user to determine and ensure the suitability of Pacific Bearing® products for a specific application. Pacific Bearing's only obligation will be to repair or replace without charge, any defective components if returned promptly. No liability is assumed beyond such replacement. *Consult www.pacific-bearing.com for the latest technical updates.

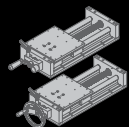

Simplicity® Linear Slides

Inch Series - 2HCR/2HWL

2HCR/2HWL – Slide Assembly with Handcrank & Ball Screw Rotational Lock

PART NUMBER

SERIES	SIZE	L	LEAD
2HXXX	- 08	- XXX	- YYY
2HXXX	- 10	- XXX	- YYY
2HXXX	- 12	- XXX	- YYY
2HXXX	- 16	- XXX	- YYY
2HXXX	- 20	- XXX	- YYY
2HXXX	- 24	- XXX	- YYY
2HXXX	- 32	- XXX	- YYY

DIMENSIONS

SHAFT DIA.	W	H	A	B	C	D	E	F	G	J
.500	6.000	2.562	1.125	2.00	3.500	1.50	.375	.75	5.500	4.000
.625	7.000	2.750	1.125	2.50	4.000	1.62	.375	.75	6.312	4.000
.750	8.000	3.438	1.500	2.75	4.500	1.75	.500	1.00	7.125	6.000
1.000	9.000	3.938	1.750	3.25	5.500	2.12	.500	1.00	8.312	6.000
1.250	11.000	5.125	2.125	4.00	6.500	2.50	.750	1.25	10.000	6.000
1.500	13.000	5.750	2.500	4.75	8.000	3.00	.750	1.25	12.000	8.000
2.000	18.000	7.375	3.250	6.00	10.000	3.75	1.000	1.50	15.875	8.000

MATERIAL:

Aluminum Alloy - Top and bottom plates, rail supports, and pillow blocks.

Alloy Steel - Shafting with proprietary low friction corrosion resistant surface treatment. Rolled ball screw and ball nut assembly.

Substitute "X" for "B" - Ball Bearing

ORDERING EXAMPLE: 2HWL-10-056-AR1

Shaft diameter in 1/16" increments (10/16 = .625")

SERIES

HANDLE DISCRIPTION

CR	Standard Model
	Cast Aluminum Counterbalanced Hand Crank
	24 and 32 (ONLY) Spoked Cast Iron Handwheel with Rigid, Revolving Crank Handle
WL	Deluxe Model
	Aluminum Handwheel with Fold-Away Composite Handle

2HCR-16-018-BRO REF.

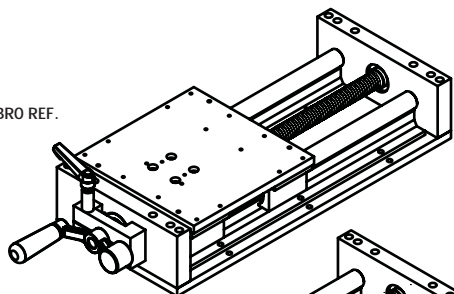

2HWL-16-018-BRO REF.

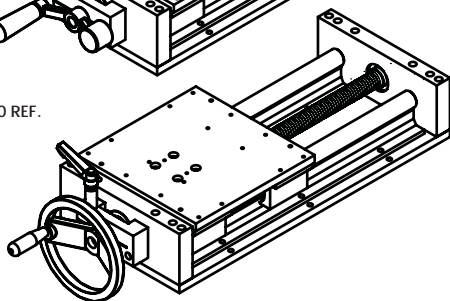

STANDARD & SELECT - BALL SCREW LEAD CODE TABLE

SIZE	AVAILABLE LEAD CODE							LEAD CODES	
08	ARX	ALX						ARX = .200 Right Hand	
10	ARX	ALX						ALX = .200 Left Hand	
12	ARX	ALX						BRX = .250 Right Hand	
16			BRX	BLX	CRX	DRX		BLX = .250 Left Hand	
20			BRX	BLX	CRX	DRX		CRX = .500 Right Hand	
24			BRX	BLX	CRX	DRX	DLX	ERX	DRX = 1.000 Right Hand
32			BRX	BLX	CRX	DRX	DLX	ERX	DLX = 1.000 Left Hand
									ERX = 1.875 Right Hand

Replace X with 0 for standard lead accurate to less than .007" per foot accumulative
 Replace X with 1 for standard lead accurate to less than .003" per foot accumulative

STANDARD LENGTH TABLE (Inches)

SIZE	AVAILABLE LENGTHS - L* (in inches)																														
08	008	012	016		020	024	028		032	036	040		044	048	052		056	060	064		068	072	076		080	084	088		092	096	
10	008	012	016		020	024	028		032	036	040		044	048	052		056	060	064		068	072	076		080	084	088		092	096	
12		012		018		024		030		036		042		048		054		060		066		072		078		084		090		096	
16		012		018		024		030		036		042		048		054		060		066		072		078		084		090		096	
20		012		018		024		030		036		042		048		054		060		066		072		078		084		090		096	
24			016			024			032			040			048			056			064			072			080		088		096
32						024			032			040			048			056			064			072			080		088		096

The data and specifications in this publication have been carefully compiled and are believed to be accurate and correct. However, it is the responsibility of the user to determine and ensure the suitability of Pacific Bearing® products for a specific application. Pacific Bearing's only obligation will be to repair or replace without charge, any defective components if returned promptly. No liability is assumed beyond such replacement. *Consult www.pacific-bearing.com for the latest technical updates.

2HCR/2HWL

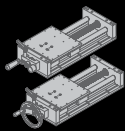

2HCR/2HWL - Slide Assembly with Handcrank & Ball Screw Rotational Lock

DIMENSIONS (Continued)

K	O	P	Q	R	S	T	U	V	X	Y	Z	TAP	HOLE DIA.	SIZE
1.38	.631	2.56	3.85	3.000	.875	1.312	4.000	4.000	4.00	2.655	4.855	10-24	.22	08
1.38	.631	2.56	3.85	3.000	.875	1.312	4.000	4.000	4.00	2.655	4.855	1/4-20	.28	10
1.50	.631	2.56	3.85	3.000	.875	1.312	4.000	4.000	4.00	2.655	4.855	1/4-20	.28	12
2.12	1.000	2.56	3.69	4.250	1.125	2.000	4.250	5.000	6.00	3.185	5.745	1/4-20	.28	16
2.38	1.000	2.56	3.69	4.250	1.125	2.000	4.250	5.000	6.00	3.185	5.745	5/16-18	.34	20
2.88	1.500	3.15	5.81	6.500	1.500	3.000	6.900	8.000	8.00	4.310	7.460	5/16-18	.34	24
3.88	1.500	3.15	5.81	6.500	1.500	3.000	6.900	8.000	8.00	4.310	7.460	3/8-16	.41	32

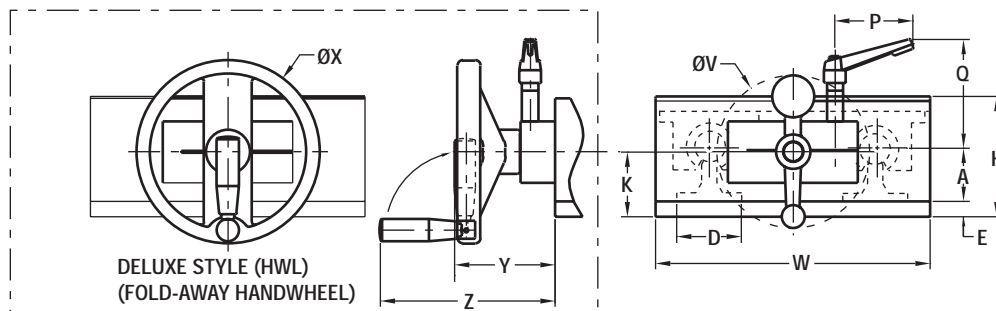
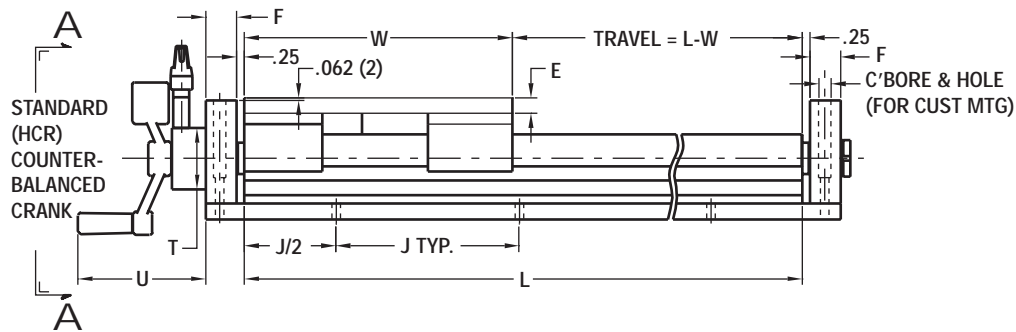
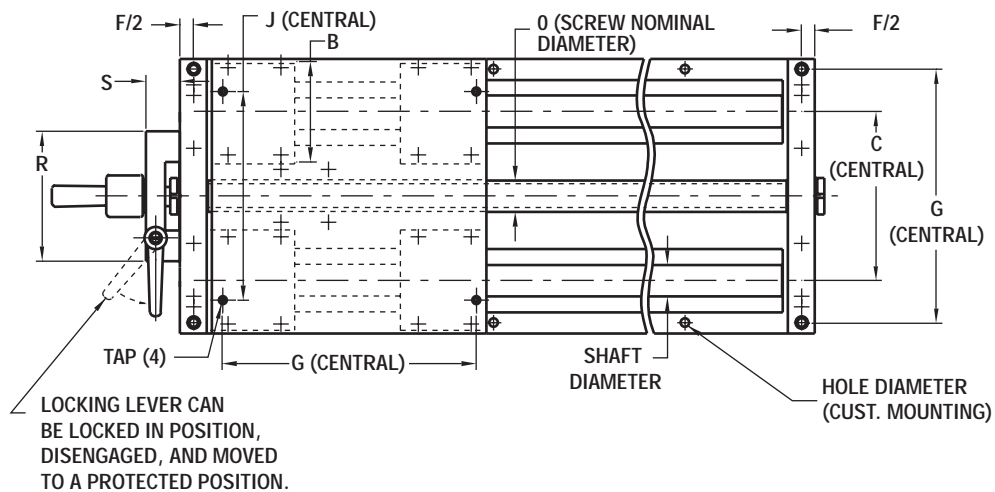

VIEW A-A

The data and specifications in this publication have been carefully compiled and are believed to be accurate and correct. However, it is the responsibility of the user to determine and ensure the suitability of Pacific Bearing[®] products for a specific application. Pacific Bearing's only obligation will be to repair or replace without charge, any defective components if returned promptly. No liability is assumed beyond such replacement. *Consult www.pacific-bearing.com for the latest technical updates.

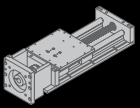

Simplicity® Linear Slides

Inch Series - 2N42, 56, 143

Linear Motion Systems

2N42, 56, 143 - Slide Assembly/NEMA Drive Kit

PART NUMBER

SERIES	SIZE	L	LEAD
2NXXX	- 16	- XXX	- XXX
2NXXX	- 20	- XXX	- XXX
2NXXX	- 24	- XXX	- XXX
2NXXX	- 32	- XXX	- XXX

DIMENSIONS

SHAFT DIA.	W	H	A	B	C	D	E
1.000	9.000	3.938	1.750	3.25	5.500	2.12	.500
1.250	11.000	5.125	2.125	4.00	6.500	2.50	.750
1.500	13.000	5.750	2.500	4.75	8.000	3.00	.750
2.000	18.000	7.375	3.250	6.00	10.000	3.75	1.000

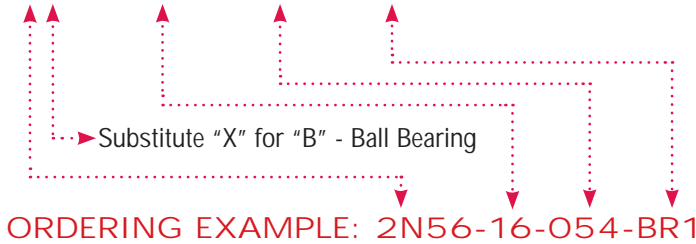

MATERIAL:

Aluminum Alloy - Top and bottom plates, rail supports, pillow blocks, and coupling.

Alloy Steel - Shafting with proprietary low friction corrosion resistant surface treatment. Rolled ball screw and ball nut assembly.

Shaft diameter in 1/16" increments (12/16 = .750")

MOTOR MOUNTING DIMENSIONS

SERIES	DRIVE	R	S	V	X	Y	Z	COUPLING ² MAX DYNAMIC TORQUE CAPACITY
42A	NEMA 42	3.000	.375	5.000	.28	3.750	2.652	200 in-lbs
42B	NEMA 42	2.188	.625	5.000	5/16-18	4.950	3.500	200 in-lbs
56	NEMA 56	4.500	.625	7.000	.41	5.875	4.154	200 in-lbs
143	NEMA 143 or 145	4.500	.875	7.000	.41	5.875	4.154	200 in-lbs

NOTE: International drives and low profile slide assemblies are available - consult factory.

² Due to ball screw and nut life/torque capacities for 16 and 20 size slides, do not exceed 100 in-lbs. of input torque without consulting factory.

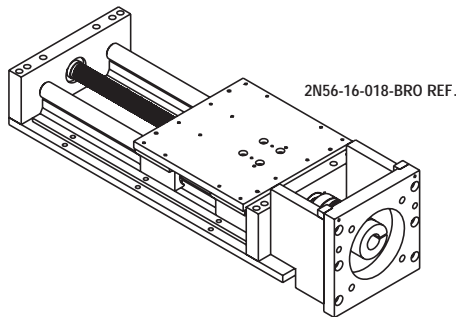

STANDARD & SELECT - BALL SCREW LEAD CODE TABLE

SIZE	AVAILABLE LEAD CODE						LEAD CODES
16	BR?	BL?	CR?	DR?			BR? = .250 Right Hand
20	BR?	BL?	CR?	DR?			BL? = .250 Left Hand
24	BR?	BL?	CR?	DR?	DL?	ER?	CR? = .500 Right Hand
32	BR?	BL?	CR?	DR?	DL?	ER?	DR? = 1.000 Right Hand
							DL? = 1.000 Left Hand
							ER? = 1.875 Right Hand

Replace ? with 0 for standard lead accurate to less than .007" per foot accumulative

Replace ? with 1 for standard lead accurate to less than .003" per foot accumulative

STANDARD LENGTH TABLE (Inches)

SIZE	AVAILABLE LENGTHS - L* (in inches)															
16	012	018	024	030	036	042	048	054	060	066	072	078	084	090	096	
20	012	018	024	030	036	042	048	054	060	066	072	078	084	090	096	
24		016	024		032	040	048	056	064		072		080	088	096	
32			024		032	040	048	056	064		072		080	088	096	

*NOTE: Longer lengths are available - consult factory.

The data and specifications in this publication have been carefully compiled and are believed to be accurate and correct. However, it is the responsibility of the user to determine and ensure the suitability of Pacific Bearing® products for a specific application. Pacific Bearing's only obligation will be to repair or replace without charge, any defective components if returned promptly. No liability is assumed beyond such replacement. *Consult www.pacific-bearing.com for the latest technical updates.

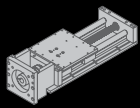

2N42, 56, 143 - Slide Assembly/NEMA Drive Kit

DIMENSIONS (Continued)

F	G	J	K	M	N	O	Q	TAP	HOLE	SIZE
1.00	8.312	6.000	2.125	.625	1.76	1.000	3.00	1/4-20	.28	16
1.25	10.000	6.000	2.375	.625	1.76	1.000	3.00	5/16-18	.34	20
1.25	12.000	8.000	2.875	1.000	2.31	1.500	2.62	5/16-18	.34	24
1.50	15.875	8.000	3.875	1.000	2.31	1.500	2.62	3/8-16	.41	32

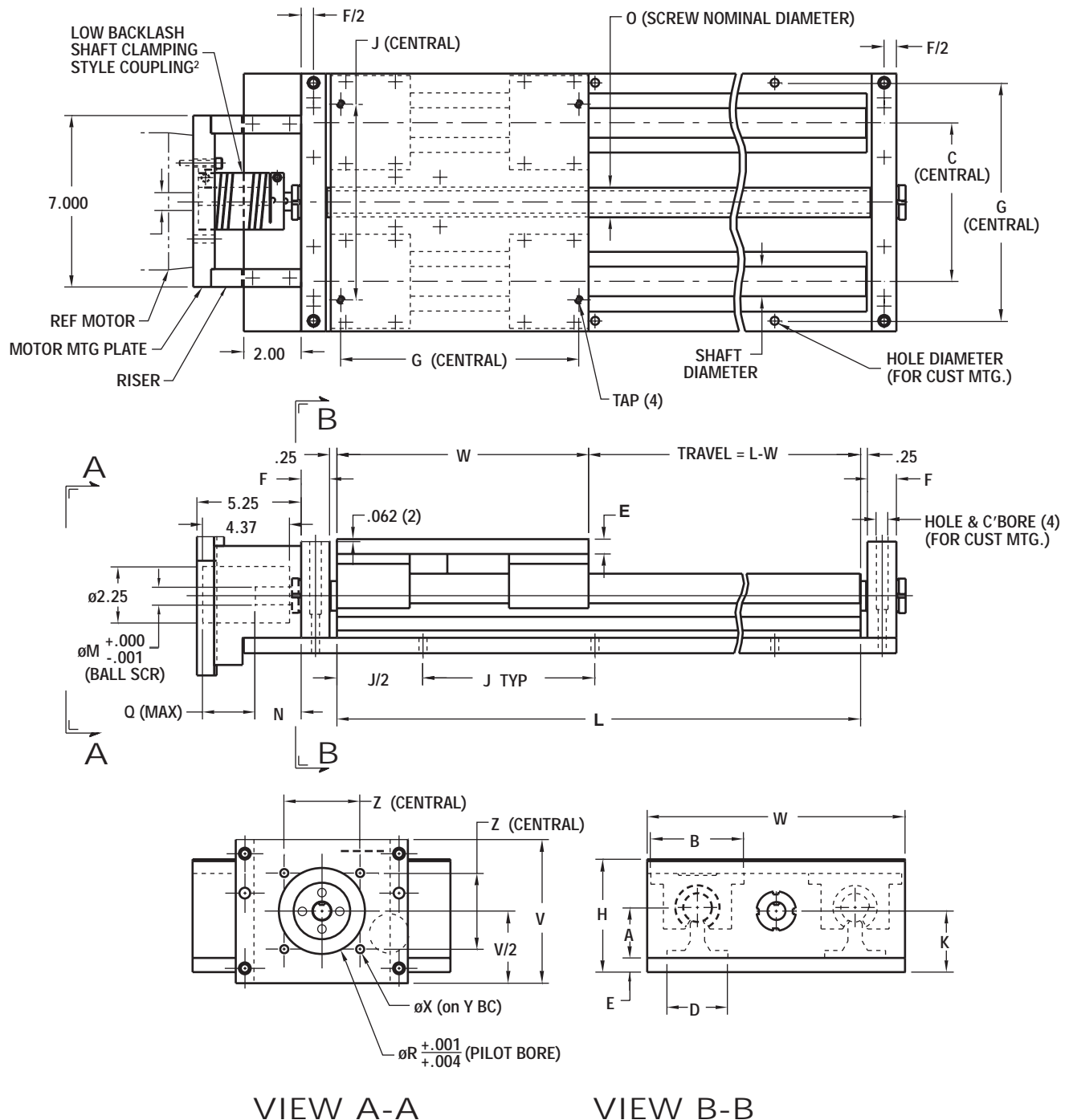

2N42, 56, 143

The data and specifications in this publication have been carefully compiled and are believed to be accurate and correct. However, it is the responsibility of the user to determine and ensure the suitability of Pacific Bearing[®] products for a specific application. Pacific Bearing's only obligation will be to repair or replace without charge, any defective components if returned promptly. No liability is assumed beyond such replacement. *Consult www.pacific-bearing.com for the latest technical updates.

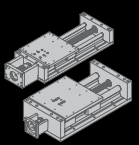

Simplicity® Linear Slides

Inch Series - 2N23 & 2N34

2N23 & 2N34 - Slide Assembly/NEMA Drive Kit

PART NUMBER

SERIES	SIZE	L	LEAD
2NXXX	08	XXX	XXX
2NXXX	10	XXX	XXX
2NXXX	12	XXX	XXX
2NXXX	16	XXX	XXX
2NXXX	20	XXX	XXX

DIMENSIONS

SHAFT DIA.	W	H	A	B	C	D	E
.500	6.000	2.562	1.125	2.00	3.500	1.50	.375
.625	7.000	2.750	1.125	2.50	4.000	1.62	.375
.750	8.000	3.438	1.500	2.75	4.500	1.75	.500
1.000	9.000	3.938	1.750	3.25	5.500	2.12	.500
1.250	11.000	5.125	2.125	4.00	6.500	2.50	.750

MATERIAL:

Aluminum Alloy - Top & bottom plates, rail supports, and pillow blocks, coupling, and motor mounts.

Alloy Steel - Shafting with proprietary low friction corrosion resistant surface treatment. Rolled ball screw & ball nut assembly.

Substitute "X" for "B" - Ball Bearing

ORDERING EXAMPLE: 2N23A-10-056-AR1

Shaft diameter in 1/16" increments (10/16 = .625")

MOTOR MOUNTING DIMENSIONS

SERIES	DRIVE	R	S	V	X	Y	Z	COUPLING ² MAX DYNAMIC TORQUE CAPACITY
23A	NEMA 23	1.502	.250	2.500	10-32	2.625	1.856	50 in-lbs
23B	NEMA 23	1.502	.375	2.500	10-32	2.625	1.856	50 in-lbs
34A	NEMA 34	1.880	.375	3.500	10-32	3.875	2.740	50 in-lbs
34B	NEMA 34	1.880	.500	3.500	10-32	3.875	2.740	50 in-lbs

NOTE: International drive configurations and low profile slide assemblies are available - consult factory

²Due to ball screw & nut life/torque capacities for sizes 08, 10, or 12 do not exceed 30 in-lbs. of input torque.

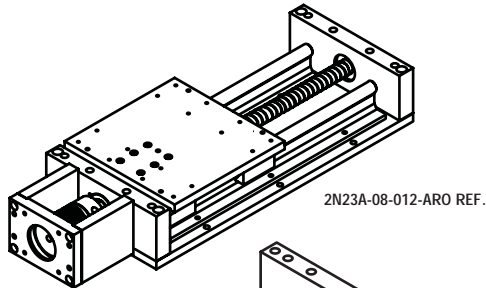

2N23A-08-012-ARO REF.

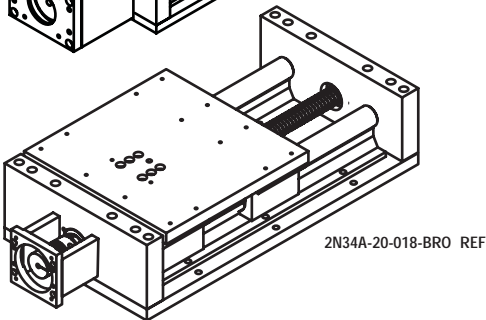

2N34A-20-018-BRO REF.

STANDARD & SELECT - BALL SCREW LEAD CODE TABLE

SIZE	AVAILABLE LEAD CODE						LEAD CODES
08	AR?	AL?					AR? = .200 Right Hand
10	AR?	AL?					AL? = .200 Left Hand
12	AR?	AL?					BR? = .250 Right Hand
16			BR?	BL?	CR?	DR?	BL? = .250 Left Hand
20			BR?	BL?	CR?	DR?	CR? = .500 Right Hand
							DR? = 1.000 Right Hand

Replace ? with 0 for standard lead accurate to less than .007" per foot accumulative

Replace ? with 1 for standard lead accurate to less than .003" per foot accumulative

STANDARD LENGTH TABLE (Inches)

SIZE	AVAILABLE LENGTHS - L* (in inches)																													
08	008	012	016		020	024	028		032	036	040		044	048	052		056	060	064		068	072	076		080	084	088		092	096
10	008	012	016		020	024	028		032	036	040		044	048	052		056	060	064		068	072	076		080	084	088		092	096
12		012		018		024		030		036		042		048		054		060		066		072		078		084		090		096
16		012		018		024		030		036		042		048		054		060		066		072		078		084		090		096
20		012		018		024		030		036		042		048		054		060		066		072		078		084		090		096

*NOTE: Longer lengths are available - consult factory

The data and specifications in this publication have been carefully compiled and are believed to be accurate and correct. However, it is the responsibility of the user to determine and ensure the suitability of Pacific Bearing® products for a specific application. Pacific Bearing's only obligation will be to repair or replace without charge, any defective components if returned promptly. No liability is assumed beyond such replacement. *Consult www.pacific-bearing.com for the latest technical updates.

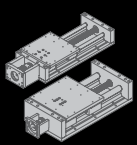

2N23 & 2N34 - Slide Assembly/NEMA Drive Kit

DIMENSIONS (Continued)

F	G	J	K	M	N	O	Q	TAP	HOLE	SIZE
.75	5.500	4.000	1.375	.375	1.45	.631	1.31	10-24	.22	08
.75	6.312	4.000	1.375	.375	1.45	.631	1.31	1/4-20	.28	10
1.00	7.125	6.000	1.500	.375	1.45	.631	1.31	1/4-20	.28	12
1.00	8.312	6.000	2.125	.625	1.76	1.000	1.19	1/4-20	.28	16
1.25	10.000	6.000	2.375	.625	1.76	1.000	1.19	5/16-18	.34	20

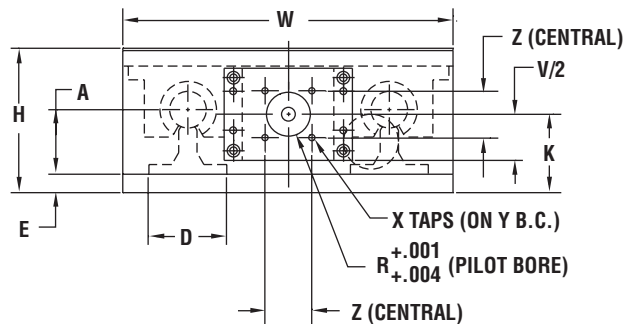
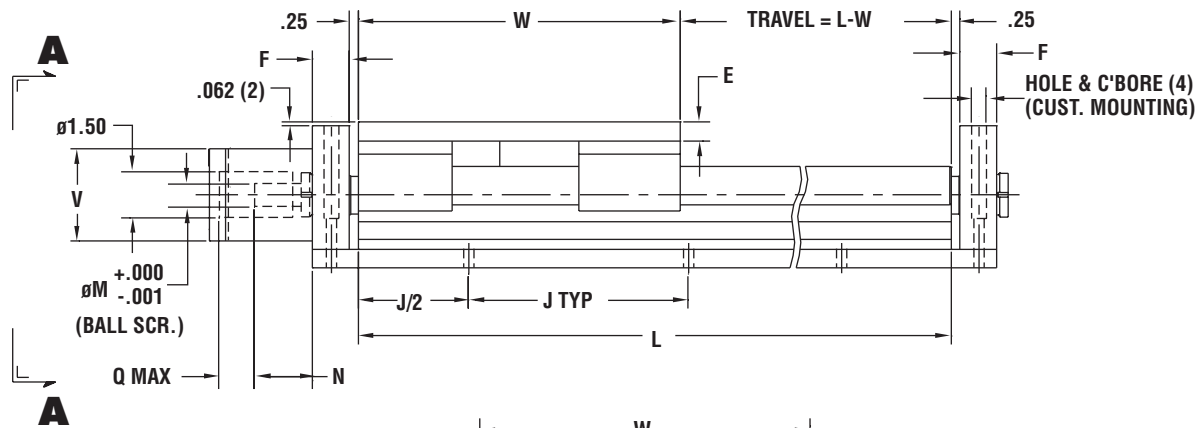
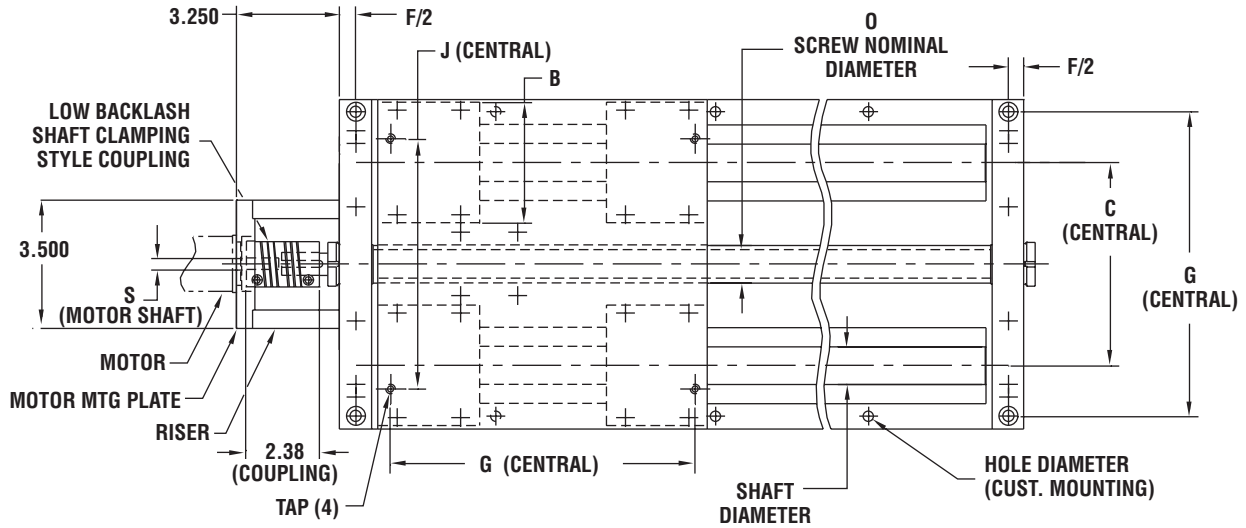

VIEW A-A

The data and specifications in this publication have been carefully compiled and are believed to be accurate and correct. However, it is the responsibility of the user to determine and ensure the suitability of Pacific Bearing[®] products for a specific application. Pacific Bearing's only obligation will be to repair or replace without charge, any defective components if returned promptly. No liability is assumed beyond such replacement. *Consult www.pacific-bearing.com for the latest technical updates.



COLUMN LOAD CHART (Ball Screw)

COMPRESSION (COLUMN) LOAD: A load that tends to buckle or compress the screw shaft.

HOW TO USE CHART:

1. Determine maximum compression load (lbs.)
2. Determine slide length. ("L" dimension)
3. Determine end fixity and slide designation (2RPS & 2LRPS).
4. Find the point at which load and length intersect.
5. Select a slide above or to the right of the intersecting point.

Applies Primarily to Vertical Application

*NOTE: Chart figures at 80% of actual load.
DO NOT EXCEED THESE FIGURES.

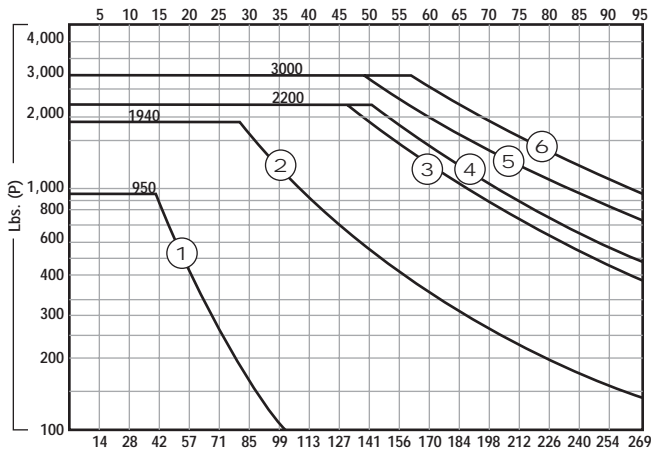
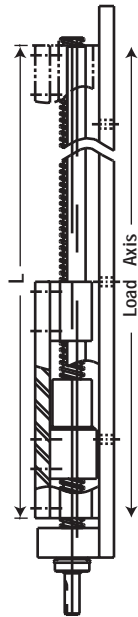

2RPS & 2LRPS (See Chart on pages 168, 169, 172 and 173)-(L)

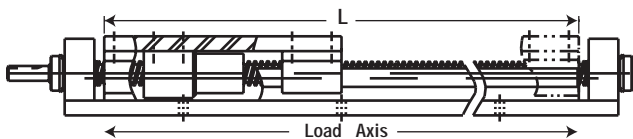

CURVE NUMBER	SLICE SERIES SIZE, LEAD
1	2RPS-08-(AR OR AL) 2LRPS-08-(AR OR AL) 2RPS-10-(AR OR AL) 2LRPS-10-(AR OR AL) 2RPS-12-(AR OR AL) 2LRPS-12-(AR OR AL) D = .500
2	2RPS-16-(BR OR BL) 2LRPS-16-(BR OR BL) 2RPS-20-(BR OR BL) 2LRPS-20-(BR OR BL) 2RPS-16-DR 2LRPS-16-DR 2RPS-20-DR 2LRPS-20-DR D = .840 2RPS-16-CR 2LRPS-16-CR 2RPS-20-CR 2LRPS-20-CR D = .870
3	2RPS-24-(DR OR DL) 2LRPS-24-(DR OR DL) 2RPS-32-(DR OR DL) 2LRPS-32-(DR OR DL) D = 1.140
4	2RPS-24-ER 2LRPS-24-ER 2RPS-32-ER 2LRPS-32-ER D = 1.190
5	2RPS-24-CR 2LRPS-24-CR 2RPS-32-CR 2LRPS-32-CR D = 1.260
6	2RPS-24-(BR OR BL) 2LRPS-24-(BR OR BL) 2RPS-32-(BR OR BL) 2LRPS-32-(BR OR BL) D = 1.375

COLUMN LOAD FORMULAS*:

$$P = C_c \cdot 14.03 \times 10^6 \cdot \left(\frac{D^4}{L^2}\right)$$

P = Critical column load (lbs.)

D = Root diameter of screw (in.) (See chart)

L = Slide length (in.)

C_c = End fixity factor

C_c = 2.0 2RPS & 2LRPS

The data and specifications in this publication have been carefully compiled and are believed to be accurate and correct. However, it is the responsibility of the user to determine and ensure the suitability of Pacific Bearing® products for a specific application. Pacific Bearing's only obligation will be to repair or replace without charge, any defective components if returned promptly. No liability is assumed beyond such replacement. *Consult www.pacific-bearing.com for the latest technical updates.



CRITICAL SPEED CHART (Ball Screw)

CRITICAL SPEED: The maximum speed at which a ball screw or ball nut can rotate without producing destructive resonant vibrations. The critical speed is a function of the ball screw diameter, the unsupported length of screw, rigidity of bearing supports, and RPM.

HOW TO USE CHART:

1. Determine end fixity. How many ends are fixed? (Slide designation, 2RPS & 2LRPS)
2. Determine slide length. ("L" dimension)
3. Find the length – fixity vertical line, read up to find the intersecting, at the required travel rate.
4. Select a slide above or to the right of the intersection point.
5. Higher speeds and/or longer lengths are available as cost effective specials, having a larger ball screw and bearings. (Consult Pacific Bearing)

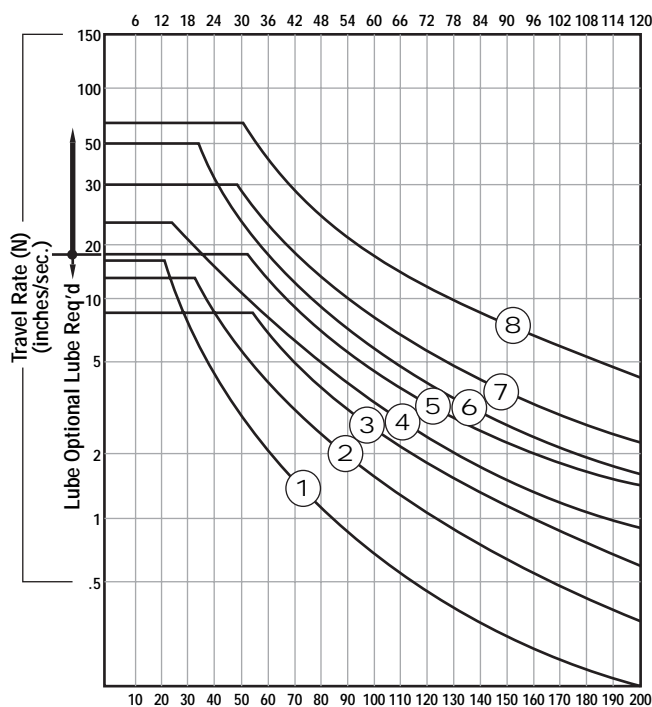
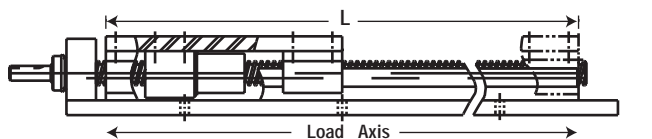

2RPS & 2LRPS (See Chart on pages 168, 169, 172 and 173)-(L)

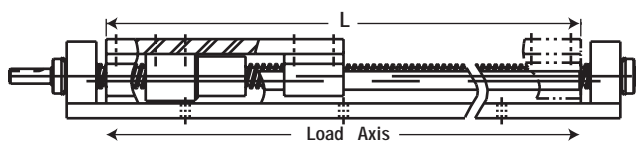

CURVE NUMBER	SLICE SERIES SIZE, LEAD	
1	2RPS-08-(AR or AL) 2LPS-08-(AR or AL) 2RPS-10-(AR or AL) 2LPS-10-(AR or AL) D = .500 H = .200	2RPS-12-(AR or AL) 2LPS-12-(AR or AL)
2	2RPS-16-(BR or BL) 2LPS-16-(BR or BL) D = .840 H = .250	2RPS-20-(BR or BL) 2LPS-20-(BR or BL)
3	2RPS-24-(BR or BL) 2LPS-24-(BR or BL) D = 1.375 H = .250	2RPS-32-(BR or BL) 2LPS-32-(BR or BL)
4	2RPS-16-(CR) 2LPS-16-(CR) D = .870 H = .500	2RPS-20-(CR) 2LPS-20-(CR)
5	2RPS-24-(CR) 2LPS-24-(CR) D = 1.260 H = .500	2RPS-32-(CR) 2LPS-32-(CR)
6	2RPS-16-(DR) 2LPS-16-(DR) D = .840 H = 1.000	2RPS-20-(DR) 2LPS-20-(DR)
7	2RPS-24-(DR or DL) 2LPS-24-(DR or DL) D = 1.140 H = 1.000	2RPS-32-(DR or DL) 2LPS-32-(DR or DL)
8	2RPS-24-(ER) 2LPS-24-(ER) D = 1.190 H = 1.875	2RPS-32-(ER) 2LPS-32-(ER)

CRITICAL SPEED FORMULAS*:

N = Critical speed (Maximum) (expressed in inches/sec.)

D = Root diameter of screw (in./Rev.) (See chart)

H = Lead of screw (in.) (See chart)

$$N = C_s \cdot 14.03 \times 10^6 \cdot \left(\frac{D^4}{L^2}\right)$$

L = Slide length (in.)

C_s = End fixity factor

C_s = 1.47 2RPS & 2LRPS

*NOTE: Chart figures at 80% of actual load.

DO NOT EXCEED THESE FIGURES.

The data and specifications in this publication have been carefully compiled and are believed to be accurate and correct. However, it is the responsibility of the user to determine and ensure the suitability of Pacific Bearing® products for a specific application. Pacific Bearing's only obligation will be to repair or replace without charge, any defective components if returned promptly. No liability is assumed beyond such replacement. *Consult www.pacific-bearing.com for the latest technical updates.

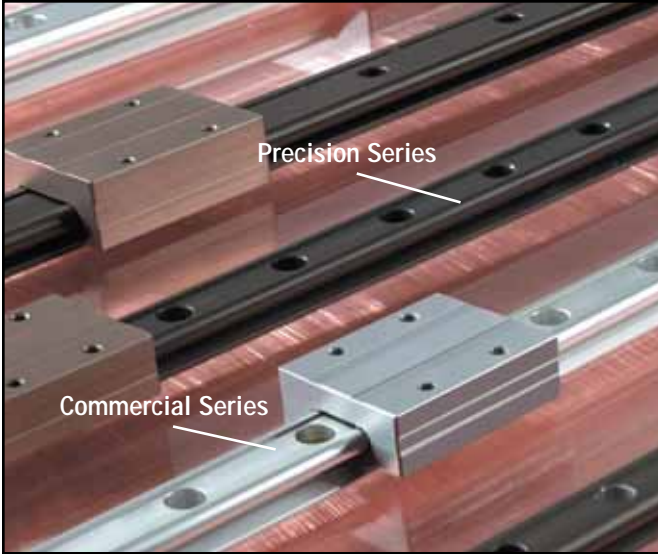

PRODUCT OVERVIEW

Based on Pacific Bearing Company's proven Simplicity technology, Mini-Rail miniature linear guides provide smooth and quiet linear motion. The self-lubricating design requires no sealing, emits virtually no particulates, tolerates high temperature extremes and has no rolling elements that can cause catastrophic failure.

Mini-Rail miniature linear guides are available in five sizes: 7, 9, 12, 15 and 20mm - in lengths up to 3600mm, meaning no cumbersome butt joints. These guides are precision manufactured out of lightweight aluminum alloys to ensure long life and corrosion resistance.

An economical alternative to conventional miniature linear guides, Mini-Rail requires no maintenance, is fully interchangeable with industry standard sizes and is maintained in stock for quick delivery.

TECHNICAL DATA

Mini-Rail is offered in three design configurations:

Precision Series: Ceramic coated rails and carriages are corrosion resistant. FrelonGold® self-lubricating liner delivers the best overall performance, the highest loads, the best wear life, and speeds. Most precise running clearance for high precision applications.

Compensated Precision Series: Same as Precision Series (above) except with additional clearance provided to tolerate misalignment.

Commercial Series: Best value for less demanding applications. Clear anodized coating provides a measure of corrosion resistance. FrelonJ® self-lubricating liner is great for washdown applications.

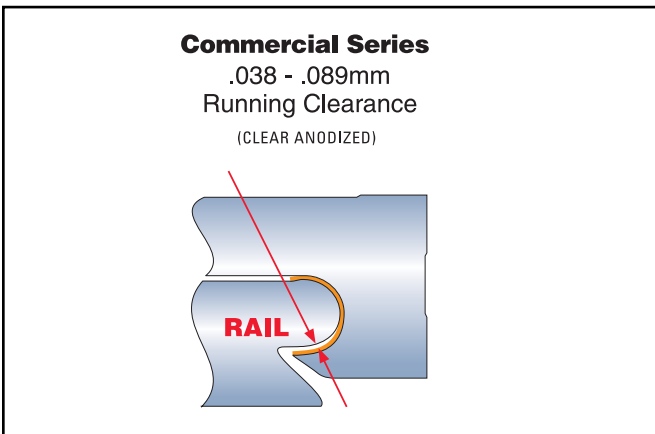
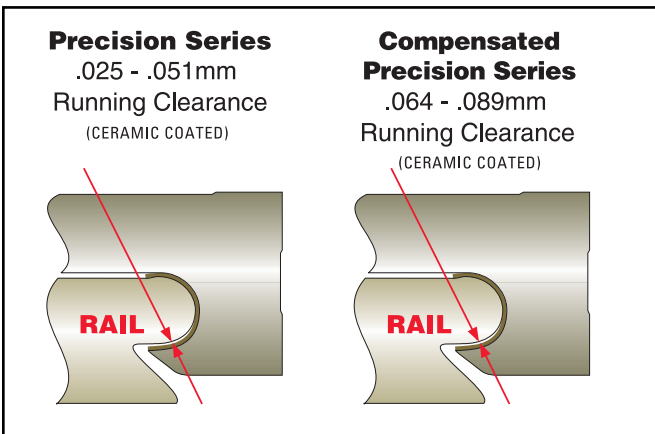

The data and specifications in this publication have been carefully compiled and are believed to be accurate and correct. However, it is the responsibility of the user to determine and ensure the suitability of Pacific Bearing® products for a specific application. Pacific Bearing's only obligation will be to repair or replace without charge, any defective components if returned promptly. No liability is assumed beyond such replacement. *Consult www.pacific-bearing.com for the latest technical updates.



(Maximum Length 3600mm)

PART NUMBER	RUNNING CLEARANCE	A	B	B1	C	D	E		F	G	H, H ₁ , H ₂			K	M	Y	X	RAIL WT. (gram/mm)	CARRIAGE WT. (gram)
		BASE WIDTH (mm)	OVERALL HEIGHT	RAIL HEIGHT	CARRIAGE WIDTH	CARRIAGE LENGTH	CARRIAGE MTG. HOLE SIZE	CARRIAGE MTG. HOLE DEPTH	CARRIAGE MTG. HOLE CTR. TO CTR.	RAIL HOLE SIZE			CARRIAGE HEIGHT	RAIL MTG. HOLE TO QUALIFIED EDGE	RAIL HOLE TO END	RAIL HOLE CTR. TO CTR.			
MR7-XXX	.025 - .051	7	8	6.1	17	24	M2 x 0.4	THRU	8	12	4.2	2.4	2.3	6.2	3.5	5	15	0.10	5.7
MRC7-XXX	.064 - .089																		
MRE7-XXX	.038 - .089																		
MR9-XXX	.025 - .051	9	10	7.1	20	30	M3 x 0.5		13	15	4.5	2.6	3	8.0	4.5	7.5	20	0.16	8.5
MRC9-XXX	.064 - .089																		
MRE9-XXX	.038 - .089																		
MR12-XXX	.025 - .051	12	13	8.0	27	34	M3 x 0.5		15	20	6	3.5	3.5	10.7	6	10	25	0.22	20.0
MRC12-XXX	.064 - .089																		
MRE12-XXX	.038 - .089																		
MR15-XXX	.025 - .051	15	16	9.2	32	42	M4 x 0.7		20	25	6	3.5	4.5	14.1	7.5	15	40	0.38	34.0
MRC15-XXX	.064 - .089																		
MRE15-XXX	.038 - .089																		
MR20-XXX	.025 - .051	20	25	13.4	46	62	M4 x 0.7	12.5	38	38	9.5	6	8.5	21.2	10	20	60	0.48	127.9
MRC20-XXX	.064 - .089																		
MRE20-XXX	.038 - .089																		

NOTES: Add the overall length of the rail to the part number, EXAMPLE "MR12-220" for a Precision Series assembly with a 220mm long rail.
Cut-to-length rails are available up to 3600mm.
The "S" dimension will remain constant at one end unless requested otherwise.

Standard and cut-to-length rail ends are NOT coated. Fully coated rails are available upon request.
All carriage mounting holes are through tapped except MR20 12.5mm of thread.

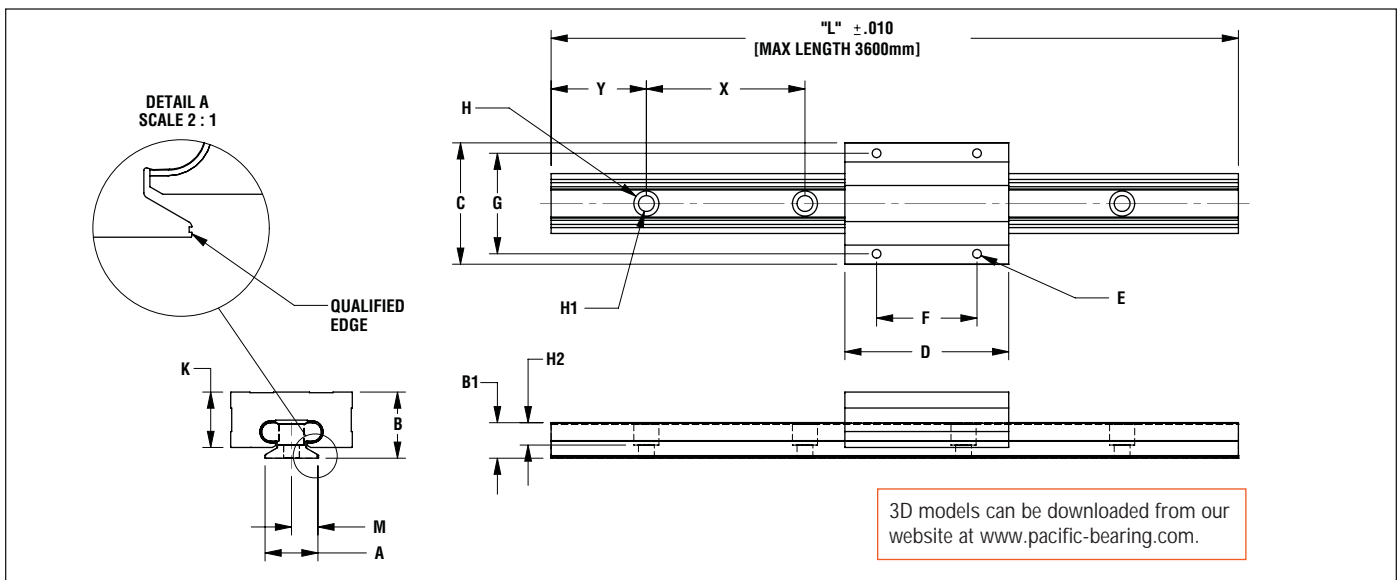

ORDERING INFORMATION

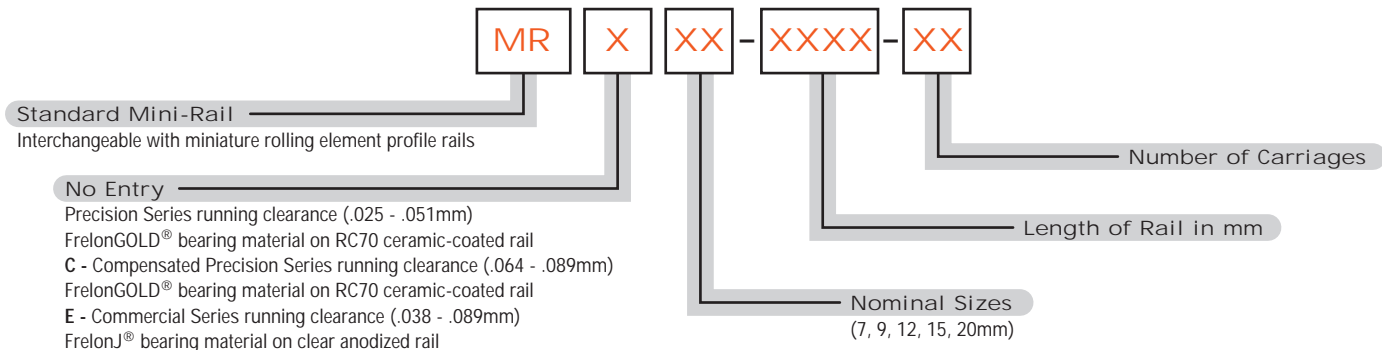

The data and specifications in this publication have been carefully compiled and are believed to be accurate and correct. However, it is the responsibility of the user to determine and ensure the suitability of Pacific Bearing® products for a specific application. Pacific Bearing's only obligation will be to repair or replace without charge, any defective components if returned promptly. No liability is assumed beyond such replacement. *Consult www.pacific-bearing.com for the latest technical updates.



STATIC LOAD DATA

The numbers below are for rails in a static condition. Refer to the calculations below to establish dynamic parameters.

SIZE	F (N)	MSL (N)*
7	445	734
9	667	1557
12	1334	1957
15	2224	3114
20	3559	6005

*Max static load in Newtons.

SIZE	F (N)
7	89
9	125
12	222
15	356
20	578

SIZE	Mx (N-m)	My (N-m)	Mz (N-m)
7	2.3	1.8	1.8
9	5.0	3.2	3.2
12	9.0	5.6	5.6
15	15.1	9.0	9.0
20	24.9	14.7	14.7

SIZE	F (N)	Mx (N-m)	My (N-m)	Mz (N-m)
7	133	2.3	1.8	1.8
9	222	5.0	3.2	3.2
12	400	9.0	5.6	5.6
15	667	15.1	9.0	9.0
20	1112	24.9	14.7	14.7

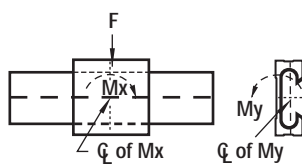
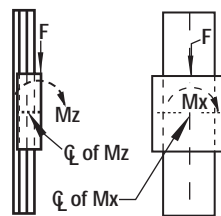
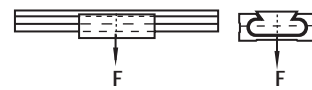
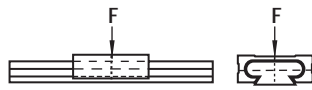

PERFORMANCE RATINGS FOR LINEAR MOTION

Plane bearings are rated by their limiting PV, which is a combination of load over a given surface area and the velocity.

BEARING MATERIAL	MAX. "PV"	MAX. "P"	MAX. "V" (NO LUBRICATION)
FrelonGold®	20,000 (psi x ft./min.) or 0.7 N/m ² x m/s	3000 psi or 20.68 N/mm ²	300 sfm or 1.524 m/s
FrelonJ®	10,000 (psi x ft./min.) or 0.35 N/m ² x m/s	1500 psi or 10.34 N/mm ²	140 sfm or 0.711 m/s

PV = The performance measurement of plane bearings.

PV = P x V, where P = pressure (load) in psi (kgf/cm²)

V = velocity (speed) in sfm (m/min.)

NOTE: All three parameters must be met by an application for the bearing to perform properly.

CANTILEVERED LOADS

Binding of the carriage will occur if the 2:1 ratio for cantilevered loads and drive forces is exceeded. This principle is not load or force dependent. It is a product of the coefficient of frictions associated with plane bearings. Contact factory or website for additional information.

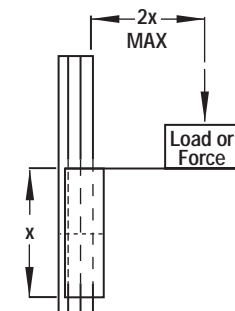

LOAD/MOMENT CONVERSION

$$N = 4.45 \times (\text{lbs.})$$

$$N\text{-m} = 0.113 \times (\text{in.-lbs.})$$

The data and specifications in this publication have been carefully compiled and are believed to be accurate and correct. However, it is the responsibility of the user to determine and ensure the suitability of Pacific Bearing® products for a specific application. Pacific Bearing's only obligation will be to repair or replace without charge, any defective components if returned promptly. No liability is assumed beyond such replacement. *Consult www.pacific-bearing.com for the latest technical updates.



MTR SERIES

- Miniature profile rail alternative
- Interchangeable with industry standards
- SimGlide™ Polymer inserts
- LaZER Straight™ rail



Materials:

LaZER Straight™ rail
SimGlide™ Polymer Inserts

Working Temperatures: -40C to 90C (-40F to 195F)

Coefficient of Friction: 0.1- 0.2

Maximum Velocity: 10 m/s (2000 fpm) for intermediate application and 8 m/s (1600 fpm) for continuous application

Maximum PV Value: 10,000 psi - fpm

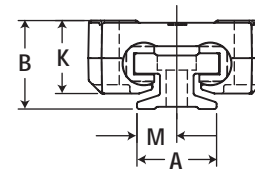
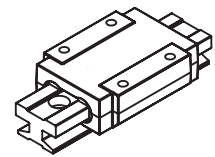
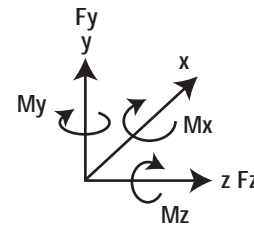
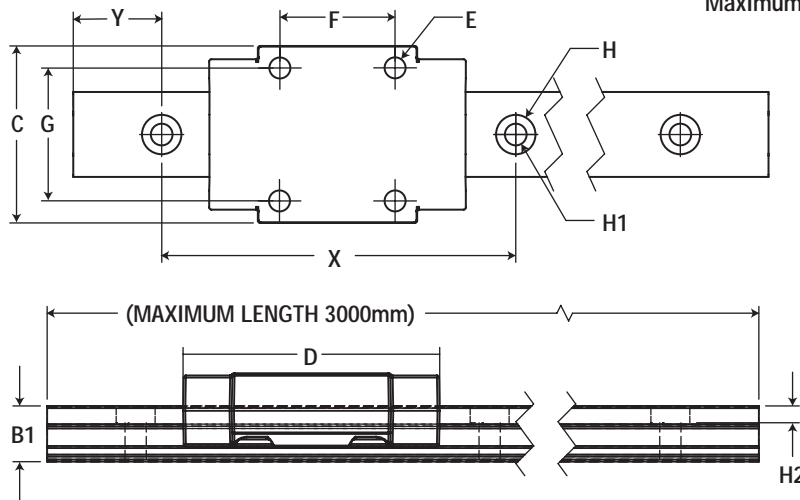

3D models can be downloaded from our website at www.pacific-bearing.com.

PART NUMBER	A (mm)	B (mm)	B1 (mm)	C (mm)	D (mm)	E (mm)	F (mm)	G (mm)	H (mm)	H1 (mm)	H2 (mm)	K (mm)	M (mm)	X (mm)	Y (mm)	CARRIAGE WT. (G)	RAIL UNIT WT. (G/mm)	LOAD CAPACITY									
																		Fy (N)	Fy (lbs.)	Fz (N)	Fz (lbs.)	Mx (N-m)	Mx (lbs.-in.)	My (N-m)	My (lbs.-in.)	Mz (N-m)	Mz (lbs.-in.)
MTR09	9	10	6.3	20	29	M2 X 0.4	13	15	4.4	2.4	2	8.3	4.5	20	5	17.6	0.11	590	130	295	65	2.4	20	1.2	11	1.2	11
MTR12	12	13	6.6	27	34	M3 X 0.5	15	20	6.5	3.4	3	11	6	25	5	37.3	0.19	995	225	500	110	5	50	2.5	24	2.5	24
MTR15	15	17	10.8	32	42	M3 X 0.5	20	25	6.5	3.4	4	13	7.5	40	10	64.9	0.32	1620	360	810	180	11	100	6	50	6	50

NOTE: Apply a load reduction factor 0.25 on Fy rating if the system is used inverted.

ORDERING INFORMATION

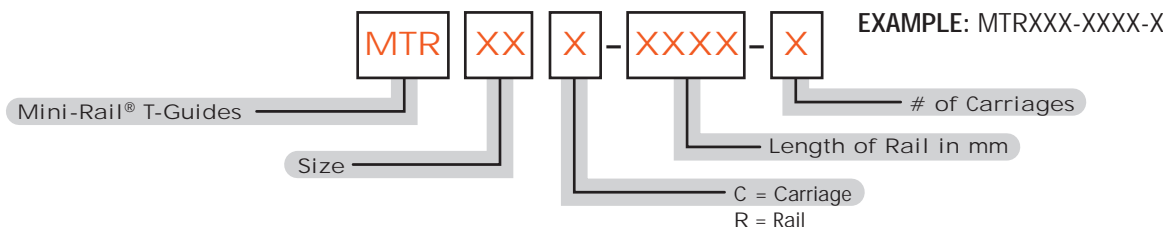

The data and specifications in this publication have been carefully compiled and are believed to be accurate and correct. However, it is the responsibility of the user to determine and ensure the suitability of Pacific Bearing® products for a specific application. Pacific Bearing's only obligation will be to repair or replace without charge, any defective components if returned promptly. No liability is assumed beyond such replacement. *Consult www.pacific-bearing.com for the latest technical updates.



Mini-Rail® Low Profile Mini-Slide

Miniature Guide/Slide Motion Systems

Linear Motion Systems

LMP Series

LPM SERIES

- Low cost
- 4 sizes
- Low profile linear guide
- Industry Standard Interchange
- Fool proof Polymer Slider



Materials: SimGlide™-J Polymer slider (UL 94 HB flammability rating)
 Molded-in stainless steel thread inserts
 Anodized aluminum rails

Operating Temperatures: -35C to 65C (-30F to 150F)
Chemical Resistance: Resistant to lubricants, fuels, dyes, weak acids
Maximum Velocity: 10 m/s
Load Reduction Factor: 0.7-1.0 for low speed application; 0.4-0.7 for medium speed application; 0.1-0.4 for high speed application

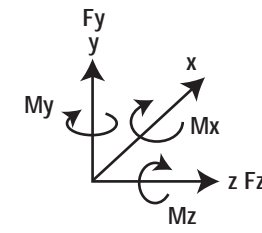
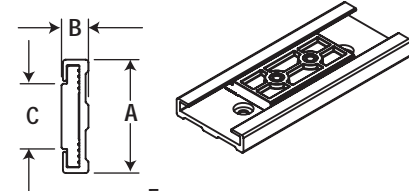
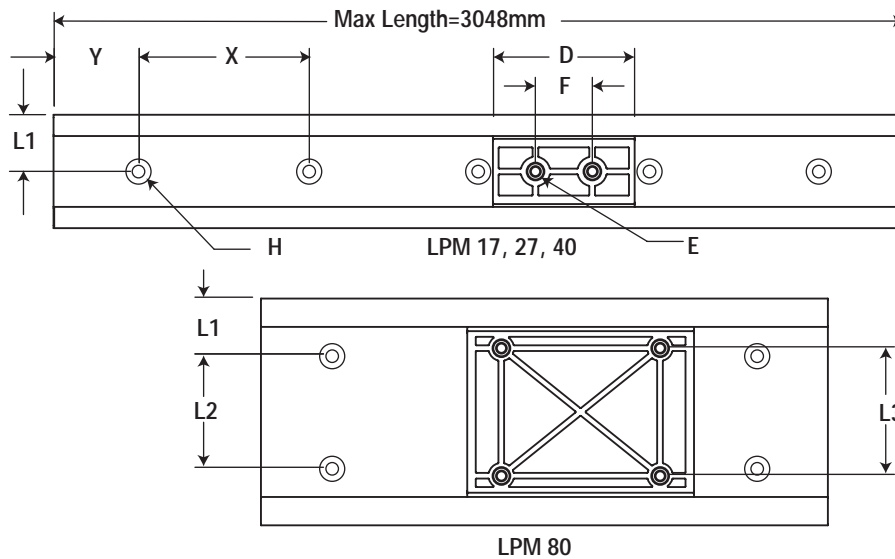

3D models can be downloaded from our website at www.pacific-bearing.com.

PART NUMBER	A (mm)	B (mm)	C (mm)	D (mm)	E (mm)	F (mm)	H (C'BORE) (mm)	L1 (mm)	L2 (mm)	L3 (mm)	Y (mm)	X (mm)	CARRIAGE WT. (G)	RAIL UNIT WT. (G/mm)	LOAD CAPACITY									
															Fy (N)	Fz (N)	Mx (N-m)	My (N-m)	Mz (N-m)	Fy (lbs.)	Fz (lbs.)	Mx (lbs.-in.)	My (lbs.-in.)	Mz (lbs.-in.)
LPM17	17	6	9.6	20	M3	14	M3 SBHCS	8.5	N/A	N/A	20	60	1.1	0.15	35	8	10	2.5	0.2	1.5	0.3	2.5	0.2	1.5
LPM27	27	9.5	14	40	M4	20	M4 SBHCS	13.5	N/A	N/A	20	60	4.8	0.33	130	30	85	20	1	10	2.5	20	1	10
LPM40	40	9.5	23	50	M4	20	M4 SBHCS	20	N/A	N/A	20	60	9.8	0.38	270	60	150	35	2.5	25	5	50	2.5	25
LPM80	80	12.0	57	80	M4	56	M4 SBHCS	20	40	45	25	150	32.3	1.07	515	120	250	55	7	60	14	125	7	60

NOTE: Apply a load reduction factor 0.25 on Fy rating if the system is used inverted.

ORDERING INFORMATION

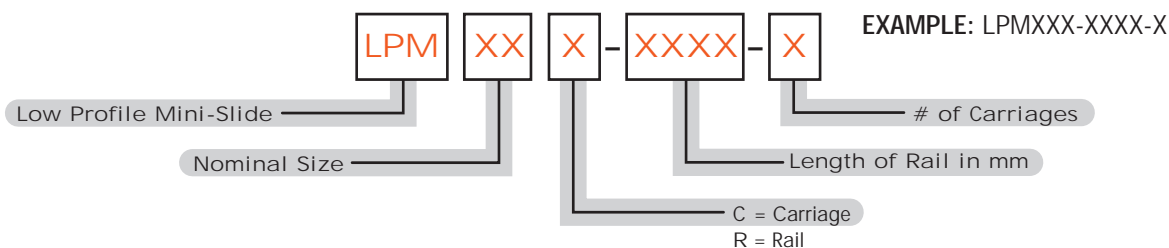

The data and specifications in this publication have been carefully compiled and are believed to be accurate and correct. However, it is the responsibility of the user to determine and ensure the suitability of Pacific Bearing® products for a specific application. Pacific Bearing's only obligation will be to repair or replace without charge, any defective components if returned promptly. No liability is assumed beyond such replacement. *Consult www.pacific-bearing.com for the latest technical updates.



MRR SERIES

- Durable polymer rollers ensure quiet operation
- Factory adjusted
- Rails can be butt-jointed for unlimited travel
- Pre-lubricated for long life
- Low cost
- Smooth operation
- Corrosion resistant
- Light loads



Materials: POM based polymer coated rollers
LaZER Straight™ ceramic coated aluminum rails
300 series stainless steel roller shafts

Working Temperatures: -20C to 90C (-4F to 195F)
Coefficient of Friction: 0.1- 0.2
Maximum Velocity: 5 m/s

Rail Weight: 0.48 G/mm
Carriage Assembly Weight: 85.0 G

Maximum Rail Length 3600 mm

M4 x 0.7 - 6h

3D models can be downloaded from our website at www.pacific-bearing.com.

NOTES: Add the overall length of the rail "L" to the part number.
EXAMPLE "MRR20-220" for a 220mm long rail.

Cut-to-length rails are available up to 3600mm.
"Y" dimension will remain constant at one end unless requested otherwise.

LOAD CAPACITY

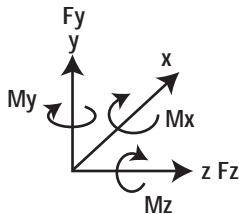

PART NUMBER	LOAD CAPACITY									
	Fy		Fz		Mx		My		Mz	
	(lbs.)	(N)	(lbs.)	(N)	(lbs.-in.)	(N-m)	(lbs.-in.)	(N-m)	(lbs.-in.)	(N-m)
MRR20	25	110	45	205	10	1.2	83	9.4	21	2.4

ORDERING INFORMATION

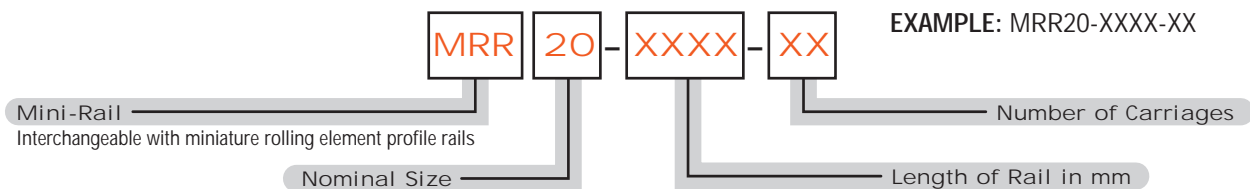

The data and specifications in this publication have been carefully compiled and are believed to be accurate and correct. However, it is the responsibility of the user to determine and ensure the suitability of Pacific Bearing® products for a specific application. Pacific Bearing's only obligation will be to repair or replace without charge, any defective components if returned promptly. No liability is assumed beyond such replacement. *Consult www.pacific-bearing.com for the latest technical updates.



Mini-Rail® LS/MS Series

Miniature Lead Screw - Driven Slides

MINI RAIL® LS/MS SPECIFICATIONS



- Bipolar
- Chopper Drive
- 100% Duty Cycle
- 5.54mm (0.218") Lead Screw

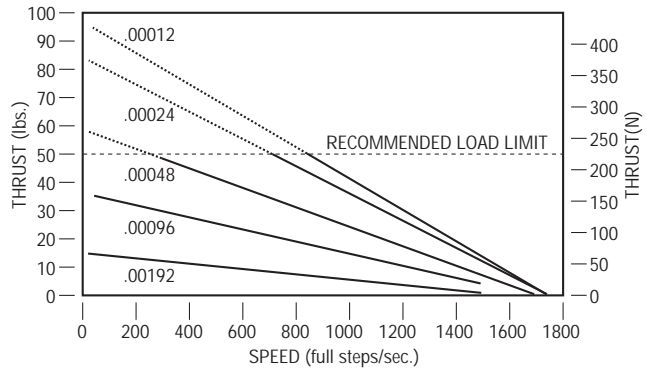

Size 17 Stepper Motor with 5.54mm (0.218") Screw

LINEAR TRAVEL PER STEP	
0.001524 mm (.00006")	
0.003048 mm (.00012")	
0.006096 mm (.00024")	
0.012192 mm (.00048")	
0.024384 mm (.00096")	
0.048768 mm (.00192")	

NOTES: Rail ends are NOT coated. Fully coated rails are available upon request.

PERFORMANCE RATINGS FOR LINEAR MOTION

Plane bearings are rated by their limiting PV, which is a combination of load over a given surface area and the velocity.

BEARING MATERIAL	MAX. "PV"	MAX. "P"	MAX. "V" (NO LUBRICATION)
FrelonGold®	20,000 (psi x ft./min.) or 0.7 N/m ² x m/s	3000 psi or 20.68 N/mm ²	300 sfm or 1.524 m/s

PV = The performance measurement of plane bearings

PV = P x V where P = pressure (load) in psi (kgf/cm²)

V = velocity (speed) in sfm (m/min.)

NOTE: All three parameters must be met by an application for the bearing to perform properly.

CANTILEVERED LOADS

Binding of the carriage will occur if the 2:1 ratio for cantilevered loads and drive forces is exceeded. This principle is not load or force dependent. It is a product of the coefficient of frictions associated with plane bearings. Contact factory or website for additional information.

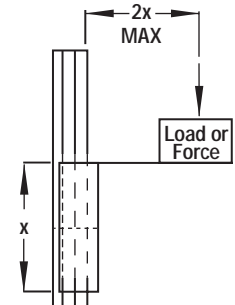

LOAD/MOMENT CONVERSION

$$N = 4.45 \times (\text{lbs.})$$

$$N\text{-m} = 0.113 \times (\text{in-lbs.})$$

STATIC LOAD DATA

The numbers below are for rails in a static condition. Refer to the calculations below to establish dynamic parameters.

F (N)	MSL (N)*
3559	6005

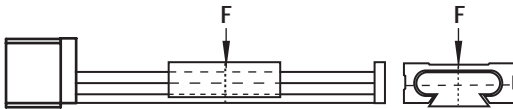

F (N)
578

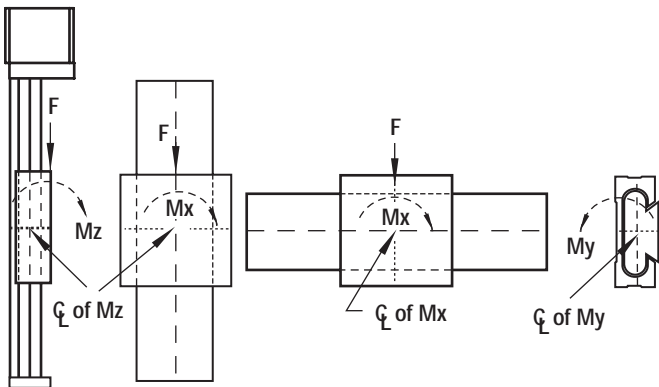
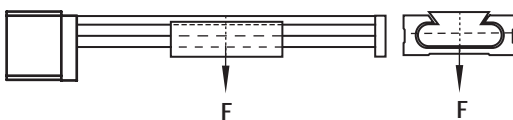

F (N)	Mx (N-m)	My (N-m)	Mz (N-m)
1112	24.9	14.7	14.7

The data and specifications in this publication have been carefully compiled and are believed to be accurate and correct. However, it is the responsibility of the user to determine and ensure the suitability of Pacific Bearing® products for a specific application. Pacific Bearing's only obligation will be to repair or replace without charge, any defective components if returned promptly. No liability is assumed beyond such replacement. *Consult www.pacific-bearing.com for the latest technical updates.



Mini-Rail® LS Series

Miniature Lead Screw - Driven Slides

LS SERIES

- Right hand rolled thread
- 303 stainless steel screw with TFE coating
- Self-lubricating Polyacetal, anti-backlash nut
- Lengths up to 640mm
- Three (3) leads available
- Optional hand brake

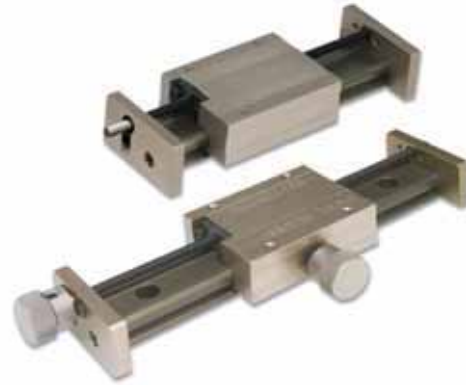

3D models can be downloaded from our website at www.pacific-bearing.com.

NOTE: Other sizes available soon!
Check our website for available sizes.

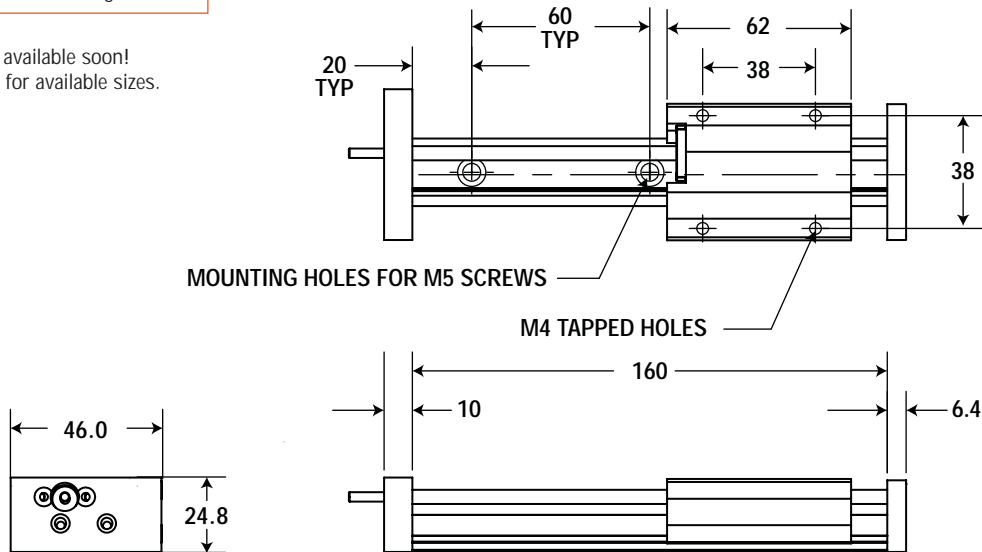

NOTES: Maximum length for lead screw driven MR is 640mm.
Standard and cut-to-length rail ends are NOT coated. Fully coated rails are available upon request.

ORDERING INFORMATION

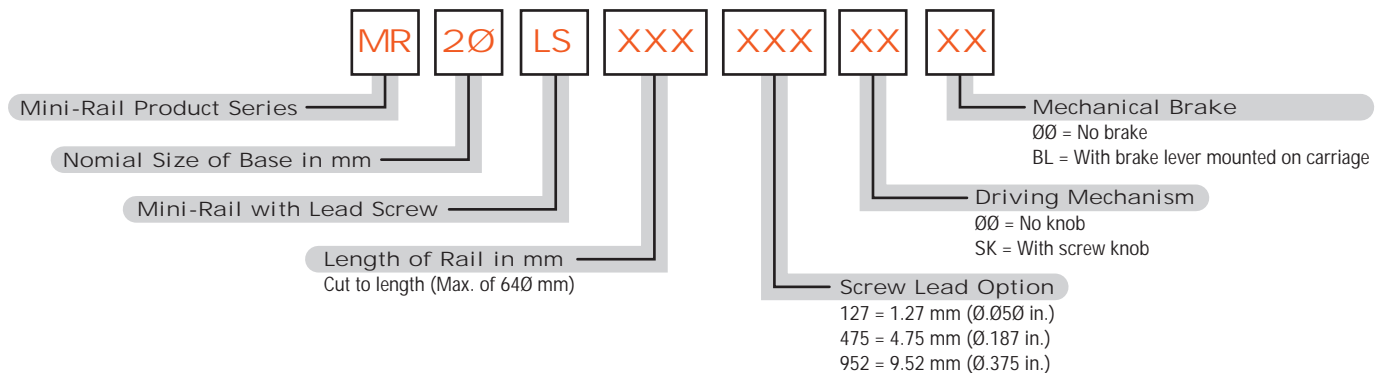

The data and specifications in this publication have been carefully compiled and are believed to be accurate and correct. However, it is the responsibility of the user to determine and ensure the suitability of Pacific Bearing® products for a specific application. Pacific Bearing's only obligation will be to repair or replace without charge, any defective components if returned promptly. No liability is assumed beyond such replacement. *Consult www.pacific-bearing.com for the latest technical updates.



Mini-Rail® MS Series

Miniature Lead Screw - Driven Slides

MS SERIES

- Robust design - outstanding reliability
- Fewer parts - less maintenance
- Preloaded drive nut - eliminates backlash
- High torque stepper motor (NEMA 17)
- Low cost
- Lengths up to 640 mm
- Ball bearing supports
- Integral screw
- Three (3) leads available



3D models can be downloaded from our website at www.pacific-bearing.com.

NOTE: Other sizes available soon! Check our website for available sizes.

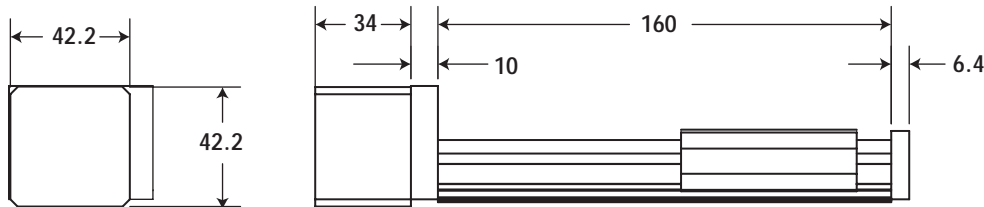
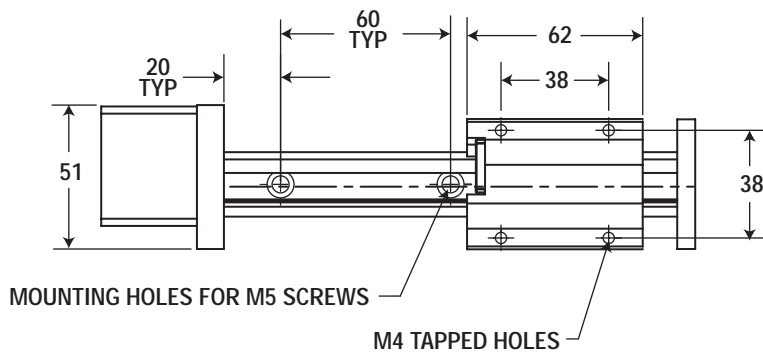

NOTES: Maximum length for lead screw driven MR is 640mm. Standard and cut-to-length rail ends are NOT coated. Fully coated rails are available upon request.

ORDERING INFORMATION

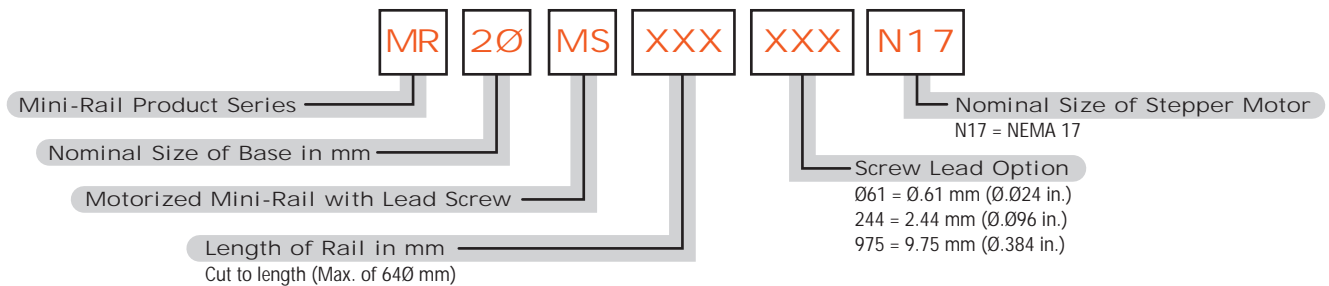

The data and specifications in this publication have been carefully compiled and are believed to be accurate and correct. However, it is the responsibility of the user to determine and ensure the suitability of Pacific Bearing® products for a specific application. Pacific Bearing's only obligation will be to repair or replace without charge, any defective components if returned promptly. No liability is assumed beyond such replacement. *Consult www.pacific-bearing.com for the latest technical updates.



PRODUCT OVERVIEW

Based on proven Simplicity® linear bearing technology, Pacific Mechatronics™ Dolphin Guides® contains FrelonGOLD® self-lubricating bearing material. This material results in no metal to metal contact, while dampening vibrations and shock loads. Dolphin Guides® unique two-piece assembly eliminates tolerance stack up and the integrated lightweight packages can drop into existing applications making installation easy.

FEATURES & BENEFITS

- Smooth & Quiet
- Standard lead screw specifications from D075, D100, and D125
- Plug and Play controls available
- Mounting Flexibility - Rails are pre-drilled for mounting ease. The carriage provides side or top mounting.
- Carriage has T-slots & mounting holes
- Drive Options - Choose from ball or lead screws, belt drives, etc. Integrate your own or consult the factory for assistance.
- FrelonGOLD® Liner - 60% less friction, 60% less wear, 100% increased load capacity, 110% increased speed limits, 100% increased PV limits
- Optional brake
- Optional Hand crank
- Clean room compatible
- Corrosion resistant
- Lightweight
- Pre-engineered, ready to use
- No bellows necessary, but are an option
- Contaminated environments, not a problem

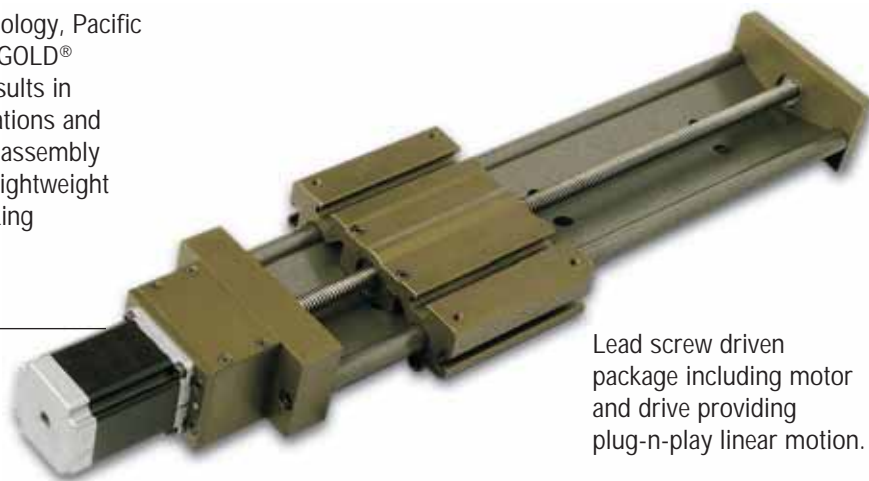
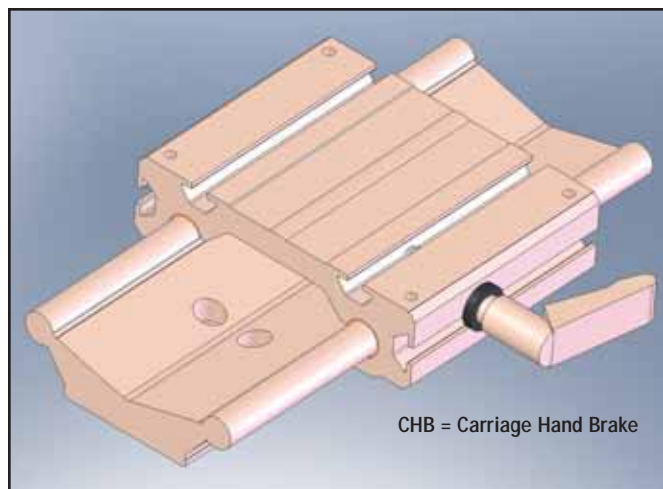

Lead screw driven package including motor and drive providing plug-n-play linear motion.

3 Types of Dolphins

- Lead Screw
- Ball Screw
- Pneumatic

TECHNICAL DRAWING

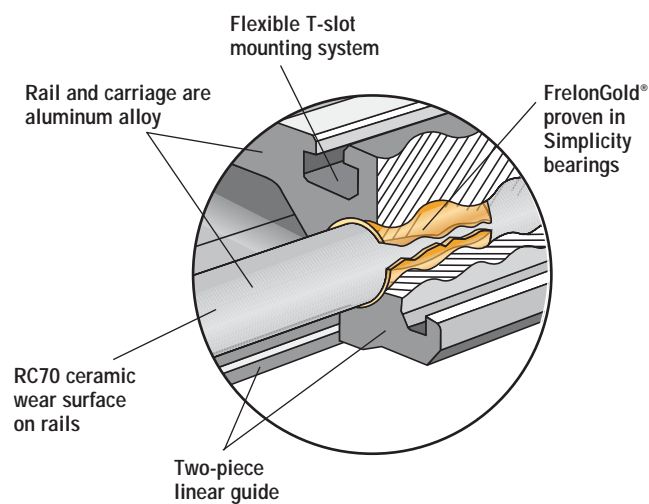

Optional configurations and special carriages are available.

The data and specifications in this publication have been carefully compiled and are believed to be accurate and correct. However, it is the responsibility of the user to determine and ensure the suitability of Pacific Bearing® products for a specific application. Pacific Bearing's only obligation will be to repair or replace without charge, any defective components if returned promptly. No liability is assumed beyond such replacement. *Consult www.pacific-bearing.com for the latest technical updates.



Precision Positioning

Dolphin Flex Linear Guide - DFG Series

Linear Motion Systems

PRODUCT OVERVIEW

- LaZer Straight™ Rail
- Modular Construction
- Industry Standard Interchange

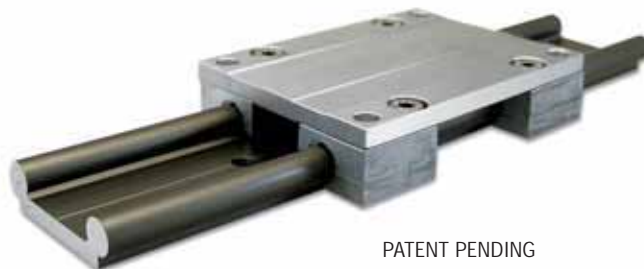

PATENT PENDING

Materials:

SimGlide™-E Polymer insert

LaZer Straight™ aluminum rails

Working Temperatures: -40C to 90C (-40F to 195F)

Coefficient of Friction: 0.1- 0.2

Maximum Velocity: 10 m/s (2000 fpm) for intermediate application and 8 m/s (1600 fpm) for continuous application

Maximum PV Value: 10,000 psi - fpm

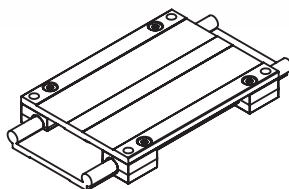

3D models can be downloaded from our website at www.pacific-bearing.com.

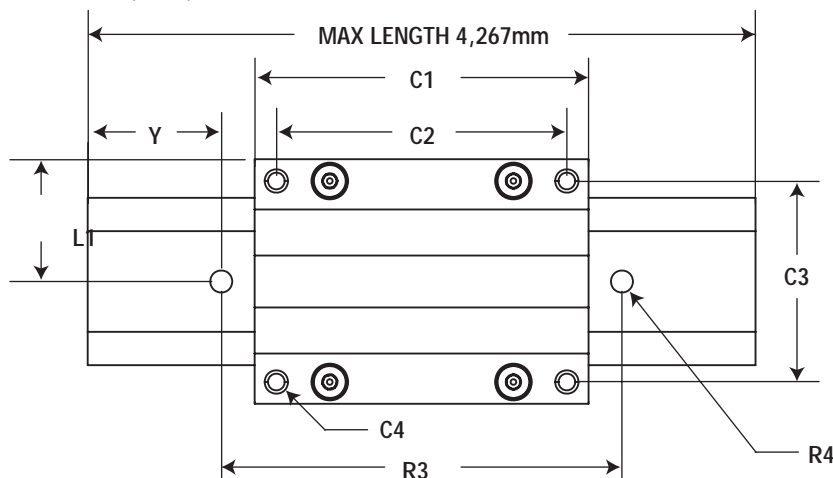
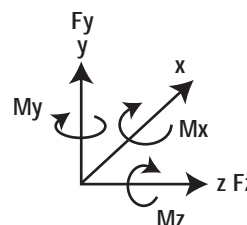

PART NUMBER	DIMENSIONAL INFORMATION											LOAD DATA											
	C	C1	C2	C3	C4	H	L1	R1	R3	R4	Y	CARRIAGE WEIGHT (G)	RAIL WEIGHT (G/mm)	Fy (N) (lbs.)		Fz (N) (lbs.)		Mx (N-m) (lbs.-in.)		My (N-m) (lbs.-in.)		Mz (N-m) (lbs.-in.)	
DFG10CA-40A	73	100	87	60	M6	24	36.5	40	120	6.6	20	310	1.0	5053	1150	4050	1020	100	75	180	135	180	135
DFG10CA-40B	73	150	137	60	M6	24	36.5	40	120	6.6	20	370	1.0	5053	1150	4050	1020	100	75	305	225	305	225
DFG10CA-40C	107	200	187	60	M6	24	36.5	40	120	6.6	20	430	1.0	5053	1150	4050	1020	100	75	430	320	430	320
DFG10CA-80A	107	100	87	94	M6	24	53.5	80	120	6.6	20	360	1.4	5053	1150	4050	1020	184	136	180	135	180	135
DFG10CA-80B	107	150	137	94	M6	24	53.5	80	120	6.6	20	450	1.4	5053	1150	4050	1020	184	136	305	225	305	225
DFG10CA-80C	107	200	187	94	M6	24	53.5	80	120	6.6	20	530	1.4	5053	1150	4050	1020	184	136	430	320	430	320

NOTE: Apply a load reduction factor 0.25 on Fy rating if the system is used inverted.

ORDERING INFORMATION

EXAMPLE:
DFG10-40A-500-1

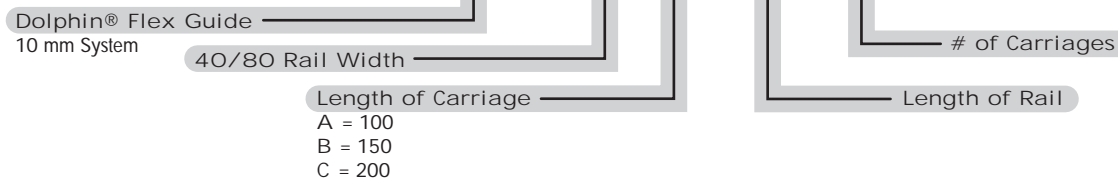

The data and specifications in this publication have been carefully compiled and are believed to be accurate and correct. However, it is the responsibility of the user to determine and ensure the suitability of Pacific Bearing® products for a specific application. Pacific Bearing's only obligation will be to repair or replace without charge, any defective components if returned promptly. No liability is assumed beyond such replacement. *Consult www.pacific-bearing.com for the latest technical updates.

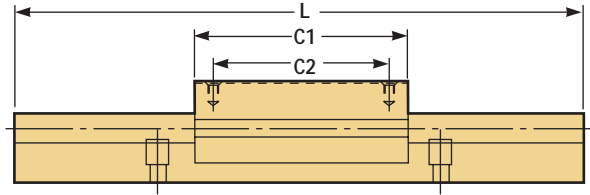
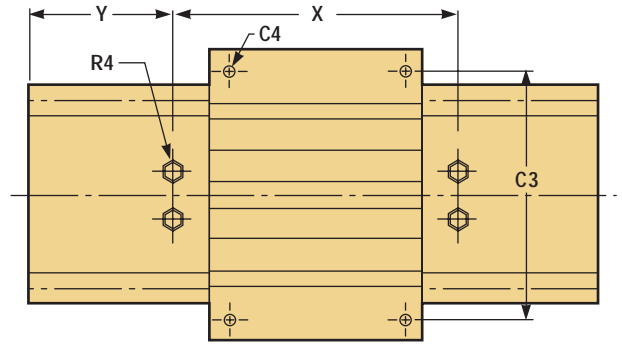
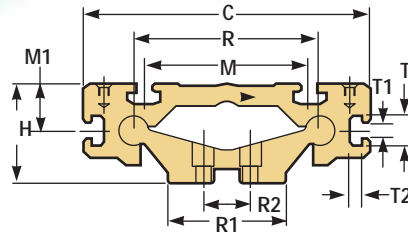

STANDARD INCH SERIES DOLPHIN GUIDE WITH NO DRIVE MECHANISM (Dimensions in Inches)

PART NUMBER	R	R1	R2	X	R4	Y	H	C	C1	C2	C1	C2	C3	C4	M	M1	L MAX-FEET
					BOLT SIZE				STANDARD	STANDARD	EXTENDED	EXTENDED		BOLT SIZE			
D075-xxx	2.95	2	0.75	4	1/4	2	1.625	4.6	3.5	3	4.5	4	4	10-32	2.6	.819	12
D100-xxx	3.94	2.6	1	6	5/16	3	2.125	6.1	4.5	3.75	6	5.25	5.25	1/4-20	3.5	1.02	
D125-xxx	4.92	3.3	1.25		3/8	3	2.625	7.6	6	5.25	7.5	6.75	6.75	5/16-18	4.33	1.30	

CARRIAGE TYPES

PART NO.	DRILL	DEPTH	TAP	DEPTH
D075-xxx	.159	.534	10-32	.440
D100-xxx	.201	.750	1/4-20	.500
D125-xxx	.257		5/16-18	.625

T-SLOT INFORMATION (Inches)

PART NO.	T	T1	T2
D075-xxx	.590	.256	.236
D100-xxx	.661	.319	.268
D125-xxx			

METRIC SERIES DOLPHIN GUIDE WITH NO DRIVE MECHANISM (Dimensions in mm)

PART NUMBER	R	R1	R2	X	R4	Y	H	C	C1	C2	C1	C2	C3	C4	M	M1	L MAX-FEET
					BOLT SIZE				STANDARD	STANDARD	EXTENDED	EXTENDED		BOLT SIZE			
DM075-xxx	75	51	20	120	M 6	60	41.3	117	85	73	110	98	105	M 5	66	16.5	3.66m
DM100-xxx	100	66	25	150	M 8	75	54	155	115	95	150	130	135	M 6	89	26	
DM125-xxx	125	84	30	200	M 10	100	66.7	193	150	130	190	170	175	M 8	110	33	

T-SLOT INFORMATION (mm)

PART NO.	T	T1	T2
DM075-xxx	15.0	6.5	6.0
DM100-xxx	16.8	8.1	6.8
DM125-xxx			

STANDARD LENGTHS CHART (Dimensions in Inches)

PART NO.	8"	12"	16"	18"	20"	24"	28"	30"	32"	36"	40"	42"	48"
D075-xxx	X		X		X		X		X		X		
D100-xxx		X		X		X		X		X		X	X
D125-xxx													

WEIGHTS

PART NO.	RAIL PER INCH	STANDARD CARRIAGE	EXTENDED CARRIAGE
	(lbs.)	(lbs.)	(lbs.)
D075-xxx	0.19	0.98	1.26
D100-xxx	0.32	2.12	2.82
D125-xxx	0.48	4.56	5.7

The data and specifications in this publication have been carefully compiled and are believed to be accurate and correct. However, it is the responsibility of the user to determine and ensure the suitability of Pacific Bearing® products for a specific application. Pacific Bearing's only obligation will be to repair or replace without charge, any defective components if returned promptly. No liability is assumed beyond such replacement. *Consult www.pacific-bearing.com for the latest technical updates.



D075

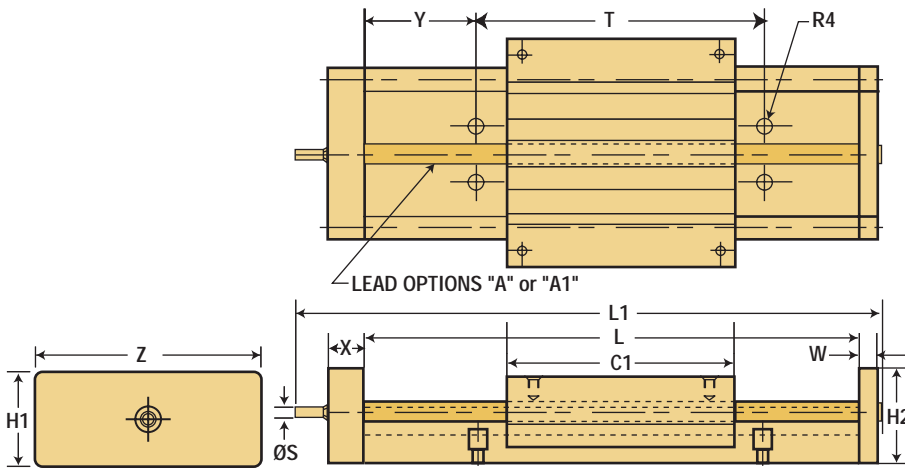

OPTIONAL HAND BRAKE

NOTE: available only with optional hand crank

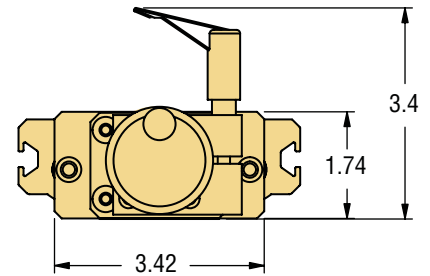

PART NO.	P	H
DO75AHB	2.31	1.75

PART NO.	STROKE	L	L1	C1	NOMINAL SCREW DIA.	STANDARD LEAD	OPTIONAL LEAD	S	Y	T	R4	W	X	Z	H1	H2
	(L-C1)					A	A1									
DO75xx-12	8.5	12	13.93	3.5	3/8"	0.250	0.500	0.187	2	4	1/4	0.375	0.625	3.42	1.75	1.625
DO75xx-16	12.5	16	17.93													
DO75xx-20	16.5	20	21.93													
DO75xx-24	20.5	24	25.93													

OPTIONAL HAND CRANK

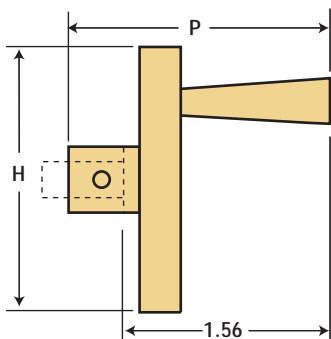

PART NO.	P	H
75H	2.31	1.75

*See order codes on page 199 to integrate.

OPTIONAL MOTOR MOUNT ATTACHMENT

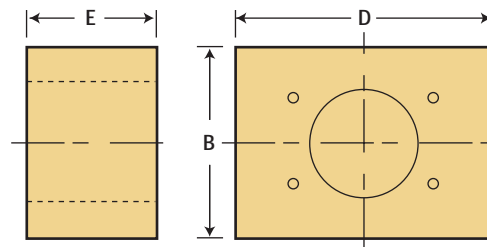

PART NO.	MOTOR MOUNT	B	E	D
75N	NEMA 17	2	1.81	3.25

LOAD & SPEED DATA FOR STANDARD LEAD SCREW DRIVEN DOLPHIN GUIDES (HORIZONTAL ORIENTATION)

D075A-xxx

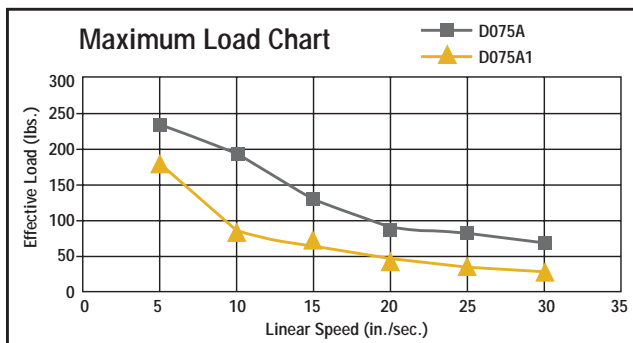

D075A-xxx

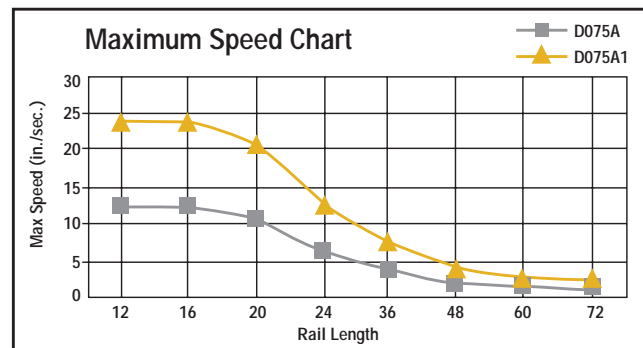

NOTE: Optional drives are available: ball screws, cylinders, linear motors, and belt drives.

The data and specifications in this publication have been carefully compiled and are believed to be accurate and correct. However, it is the responsibility of the user to determine and ensure the suitability of Pacific Bearing® products for a specific application. Pacific Bearing's only obligation will be to repair or replace without charge, any defective components if returned promptly. No liability is assumed beyond such replacement. *Consult www.pacific-bearing.com for the latest technical updates.



D100

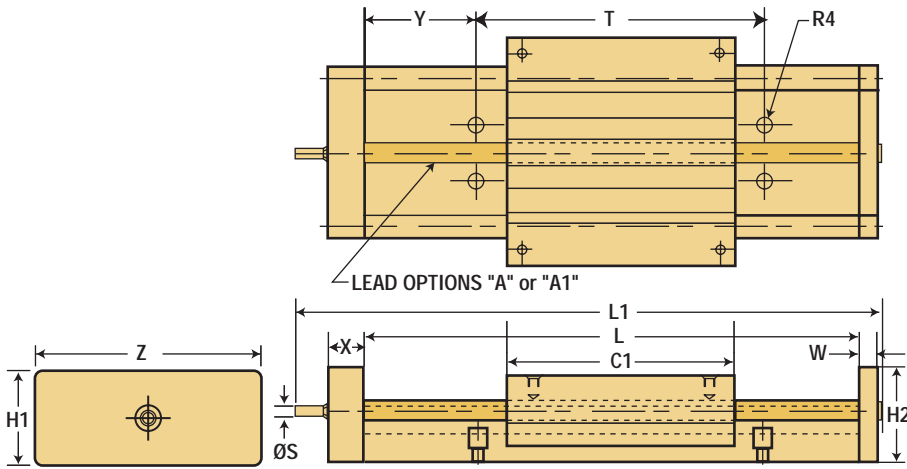

OPTIONAL HAND BRAKE

NOTE: available only with optional hand crank

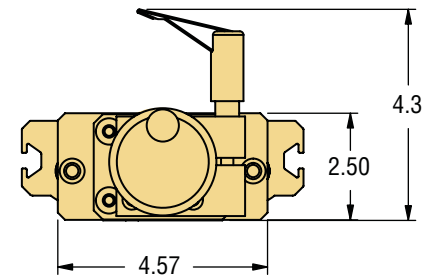

PART NO.	P	H
DO100AHB	2.31	1.75

PART NO.	STROKE	L	L1	C1	NOMINAL SCREW DIA.	STANDARD LEAD	OPTIONAL LEAD	S	Y	T	R4	W	X	Z	H1	H2
	(L-C1)					A	A1									
D100xx-12	7.5	12	14.61	4.5	1/2	0.250	0.500	0.314	3	6	5/16	0.5	1	4.56	2.5	2.500
D100xx-18	13.5	18	20.61													
D100xx-24	19.5	24	26.61													
D100xx-30	25.5	30	32.61													
D100xx-48	25.5	30	32.61													

OPTIONAL HAND CRANK

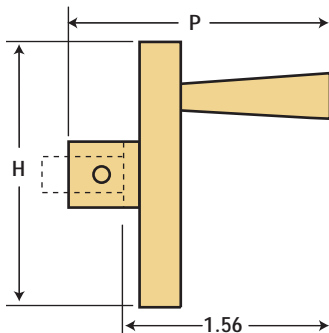

PART NO.	P	H
100H	2.31	2.25

*See order codes on page 199 to integrate.

OPTIONAL MOTOR MOUNT ATTACHMENT

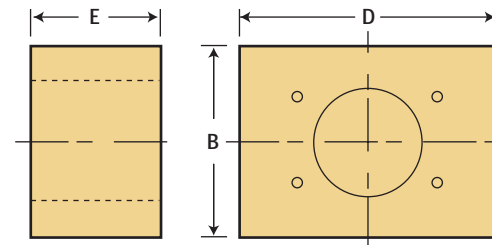

PART NO.	MOTOR MOUNT	B	E	D
100N	NEMA 23	2.5	1.81	3.25

LOAD & SPEED DATA FOR STANDARD LEAD SCREW DRIVEN DOLPHIN GUIDES (HORIZONTAL ORIENTATION)

D100A-xxx

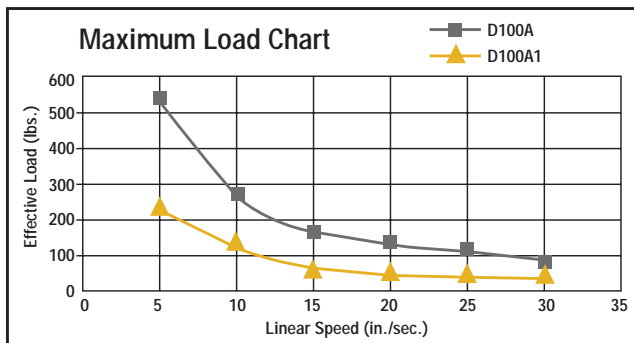

D100A-xxx

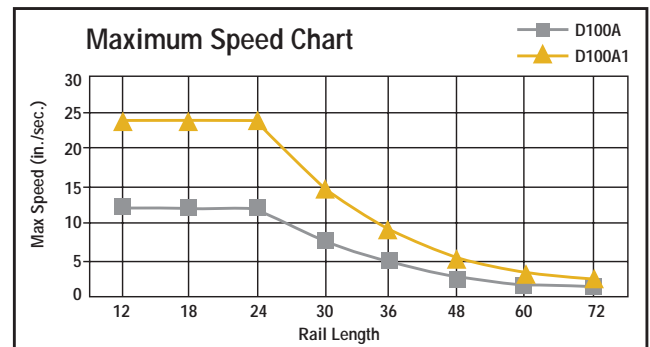

NOTE: Optional drives are available: ball screws, cylinders, linear motors, and belt drives.

The data and specifications in this publication have been carefully compiled and are believed to be accurate and correct. However, it is the responsibility of the user to determine and ensure the suitability of Pacific Bearing® products for a specific application. Pacific Bearing's only obligation will be to repair or replace without charge, any defective components if returned promptly. No liability is assumed beyond such replacement. *Consult www.pacific-bearing.com for the latest technical updates.



D125

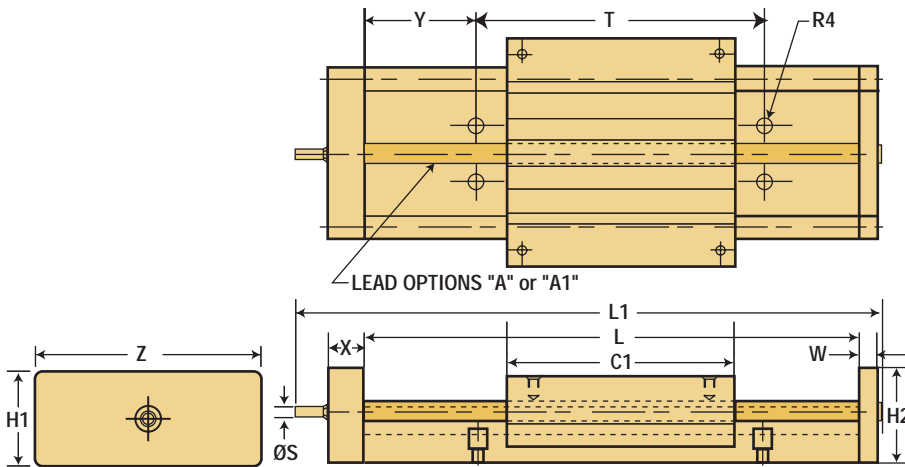

OPTIONAL HAND BRAKE

NOTE: available only with optional hand crank

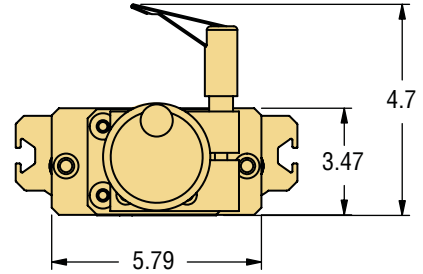

PART NO.	P	H
D0125AHB	2.31	1.75

PART NO.	STROKE	L	L1	C1	NOMINAL SCREW DIA.	STANDARD	OPTIONAL	S	Y	T	R4	W	X	Z	H1	H2
	(L-C1)					LEAD	LEAD									
						A	A1									
D125xx-12	6	12	14.85													
D125xx-18	12	18	20.85													
D125xx-24	18	24	26.85													
D125xx-30	24	30	32.85	6	5/8	0.200	0.500	0.314	3	6	3/8	0.5	1	5.78	3.5	2.500
D125xx-36	30	36	38.85													
D125xx-48	30	48	38.85													
D125xx-60	30	60	38.85													

OPTIONAL HAND CRANK

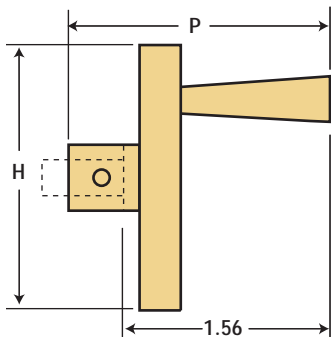

PART NO.	P	H
125H	2.31	3.25

*See order codes on page 199 to integrate.

OPTIONAL MOTOR MOUNT ATTACHMENT

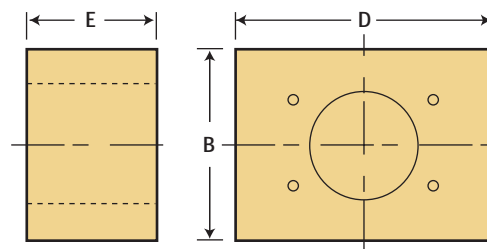

PART NO.	MOTOR MOUNT	B	E	D
125N	NEMA 34	3.5	2.3	4.25

LOAD & SPEED DATA FOR STANDARD LEAD SCREW DRIVEN DOLPHIN GUIDES (HORIZONTAL ORIENTATION)

D125A-xxx

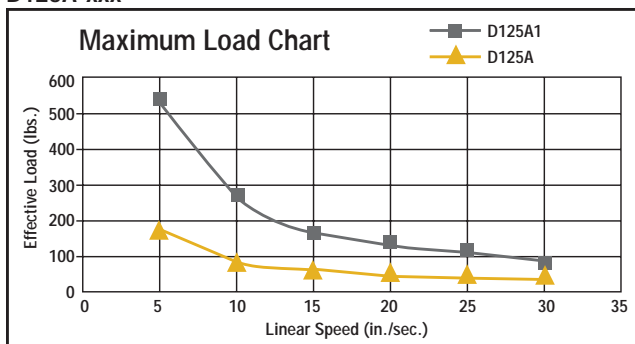

D125A-xxx

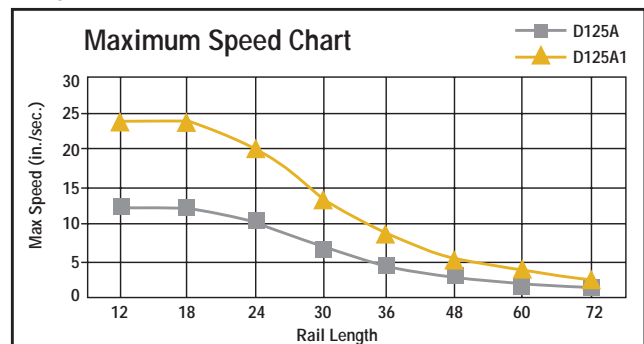

NOTE: Optional drives are available: ball screws, cylinders, linear motors, and belt drives.

The data and specifications in this publication have been carefully compiled and are believed to be accurate and correct. However, it is the responsibility of the user to determine and ensure the suitability of Pacific Bearing® products for a specific application. Pacific Bearing's only obligation will be to repair or replace without charge, any defective components if returned promptly. No liability is assumed beyond such replacement. *Consult www.pacific-bearing.com for the latest technical updates.



STATIC LOADS WITH NO DRIVE MECHANISM

The numbers below are for guides only in a static condition. The drive mechanism selected (lead screw, ball screw, cylinder, etc.) becomes the limiting factor when calculating maximum load and speed capacities. The user is responsible for determining the maximum capacity for the complete system based on the manufacturer's data for their drive configuration.

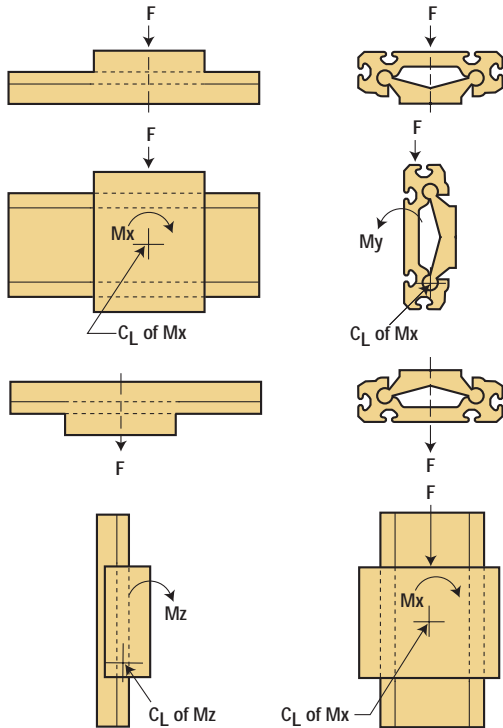

Designs must also operate within the following dynamic parameters:

- Maximum Loads (P) = from charts above
- Maximum Speed Dry (V) = 300 ft./min. (1.524 m/s)
- Maximum PV (pressure x velocity) = 20,000 (0.70 N/mm² x m/s)
- PV Example: Load = 85 psi
Speed = 180 ft./min.
PV = 85 x 180 = 15,300 PV

NOTE: FrelonGold® bearing material coefficient of friction is 0.125.

SIZE	F MAX LOAD (lbs.)	F MAX LOAD (N)
D075	500	2,224
D100	750	3,336
D125	1,000	4,448

SIZE	F MAX LOAD (lbs.)	Mx (in./lbs.)	My (in./lbs.)	F MAX LOAD (N)	Mx (Nm)	My (Nm)
D075	250	340	350	1,112	38	40
D100	375	650	730	1,668	73	82
D125	500	1,200	1,225	2,224	136	138

SIZE	F MAX LOAD (lbs.)	F MAX LOAD (N)
D075	125	556
D100	190	845
D125	250	1,112

SIZE	Mx (in./lbs.)	My (in./lbs.)	Mx (Nm)	My (Nm)
D075	340	350	38	40
D100	650	730	73	82
D125	1,200	1,225	136	138

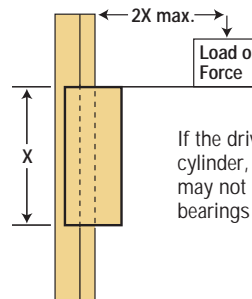

If the drive mechanism (lead screw, ball screw, cylinder, etc.) is centered on the carriage, the load may not exceed a 2:1 ratio to the length of the bearings or binding will occur.

ORDERING INFORMATION

D L M 100 A CHB - xxx P M - X

- Series**
 - D - Standard Dolphin Guides
- Carriage Options**
 - No Entry - Standard Dolphin Carriage
 - L - Extended Length Carriage
- Mounting Hole Options**
 - No Entry - Standard Inch Sizes
 - M - Metric Size Mounting Holes
- Nominal Size**
 - 75mm, 100mm, 125mm
 - Based on mm from shaft center-to-center
- Drive Options**
 - No Entry - No Drive Mechanism
 - A - Right Hand Lead Screw with Standard Pitch
 - A1 - Right Hand Lead Screw with Optional Pitch (See pages 196, 197 & 198 for specifications.)
 - Notes: Screw options require attaching collar. Call the factory for other optional drive mechanisms.
- Overall Rail Length**
 - "D" Series - Enter Length of Rail in Inches
 - "DM" Series - Enter Length of Rail in mm
- Drive Mounting Options**
 - No Entry - No Drive Mounting Options
 - H - Hand Crank
 - N - NEMA Standard Motor Mount (See pages 196, 197 & 198 for specifications.)
 - HB - Handbrake (requires handcrank and screw)
 - CHB - Carriage Handbrake (not offered with screw driven options)
- Power and Control Options**
 - No Entry - No Power Options
 - P - Standard Motor with Motor Mount, Programmable Drive, Cables and Software (must have "N" in Drive Mounting Option)
 - Note: Kits available for NEMA motor
- Data Entry Option**
 - No Entry - No Options
 - M - Optional MMI Keypad (Man-to-Machine Interface)
- Number of Carriages**
 - X

The data and specifications in this publication have been carefully compiled and are believed to be accurate and correct. However, it is the responsibility of the user to determine and ensure the suitability of Pacific Bearing® products for a specific application. Pacific Bearing's only obligation will be to repair or replace without charge, any defective components if returned promptly. No liability is assumed beyond such replacement. *Consult www.pacific-bearing.com for the latest technical updates.



ADJUSTING SLIDE PRELOAD

The preload of a slide should be properly set from the factory, but if you must adjust it yourself, here are some simple steps to follow.

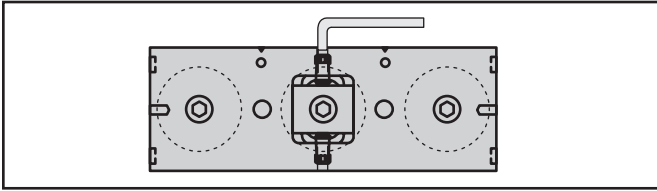

Metric Series

1. To loosen the eccentric (center) roller, use an Allen wrench to loosen the screw that is on the side of the mounting block. Be sure to loosen the screw that is on the side of the direction you want the roller to move.
2. When it is loose, tighten the set screw on the opposite side of the block. This will move the roller and mounting stud.
3. Make a very small change, retighten the first set screw, and try it out. If the preload is too loose, you will feel the slider rock and you will hear a slight "clunk." If it is too tight, the slider will roll rough, like riding a bicycle on a gravel road.
4. Move the slide along the length of the rail by hand. Adjust it so that it does not feel loose anywhere. It may take you several times to get the proper adjustment.
5. Make sure the rollers are tightened with the proper adjustment prior to operation.

SLIDER ORIENTATION

The 3-Roller slide should be installed in the rail so the load is shared on the two outside rollers. The orientation marks indicate how to align the slider with the load direction.

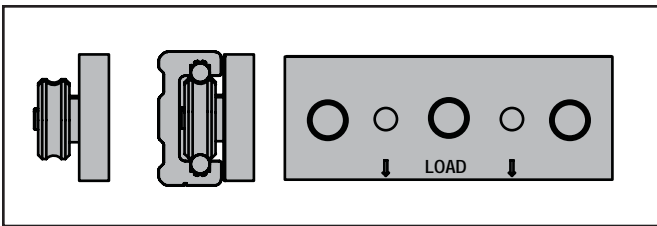

LUBRICATION - RAILS & BEARINGS

The rollers are internally lubricated for life, but the rails must always have a layer of grease. As a guideline, reapply fresh grease every 50,000 cycles.

MOUNTING SLIDER BODY & MAX CAPACITY

Below are recommended bolt tightening torques for mounting to the slide body. Be sure to use bolts that are long enough to obtain full thread engagement.

MOUNTING TORQUES

PART NUMBER	IN-LBS. TORQUE	NM TORQUE
RRS14 RRS30	25	3
RRS18 RRS45	70	8
RRS65	150	24

LIFE CALCULATIONS

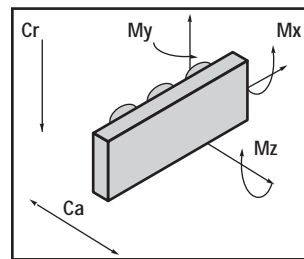

C_d = Dynamic capacity (LC)
 C_r = Radial capacity
 C_a = Axial capacity
 M_x, M_y, M_z = Moment capacities

Conversions

newton (N) x 0.2248 = lbs.
 (lbf) meter x 0.0397 = inch
 newton - meter (Nm) x 8.851 = in.-lbs.

INCH SERIES

PART NUMBER	C_r (lbs.)	C_a (lbs.)	M_x (in.-lbs.)	M_y (in.-lbs.)	M_z (in.-lbs.)
RRS14	336	79	21	54	201
RRS18	847	168	67	153	677

METRIC SERIES

PART NUMBER	C_r (N)	C_a (N)	M (Nm)	M_y (Nm)	M_z (Nm)
RRS30	1,002	330	1.8	5.5	12.5
RRS45	2,660	827	6.6	19.9	47.9
RRS65	5,950	1,678	19.0	58.2	154.7

The data and specifications in this publication have been carefully compiled and are believed to be accurate and correct. However, it is the responsibility of the user to determine and ensure the suitability of Pacific Bearing® products for a specific application. Pacific Bearing's only obligation will be to repair or replace without charge, any defective components if returned promptly. No liability is assumed beyond such replacement. *Consult www.pacific-bearing.com for the latest technical updates.



LIFE CALCULATIONS (cont.)

To calculate an approximate life for redi-rail sliders, use the following equation.

Inch Series

The value of L_{RR} is in meters

$$L_{RR} = 10^7 \cdot (Cd / (\text{Load}_{\text{Equiv}} \cdot RF))^{3.0} \text{ (inches)}$$

LC_{RRS} = Slider Life Capacity which is found in the table

$\text{Load}_{\text{Equiv}}$ = Equivalent Radial Load found from the following equation:

$$\text{Load}_{\text{Equiv}} = Cr \cdot \left(\frac{\text{Load}_{\text{Axial}}}{Ca} + \frac{M_x}{M_x \text{ Max}} + \frac{M_y}{M_y \text{ Max}} + \frac{M_z}{M_z \text{ Max}} \right) + \text{Load}_{\text{Radial}}$$

INCH SERIES

PART NUMBER	MAX SPEED (fpm)	MAX SPEED (rpm)	Cd
RRS14	500	6000	421
RRS18	800	9,600	1,032

Metric Series

The value of L_{RR} is in meters

$$L_{RR} = (Cd / \text{Load}_{\text{Equiv}} \cdot RF)^{3.0} \times 100,000 \text{ meters}$$

Cd = Slider Life Capacity which is found in the table

$\text{Load}_{\text{Equiv}}$ = Equivalent Radial Load found from the following equation:

$$\text{Load}_{\text{Equiv}} = Cr \cdot \left(\frac{\text{Load}_{\text{Axial}}}{Ca} + \frac{M_x}{M_x \text{ Max}} + \frac{M_y}{M_y \text{ Max}} + \frac{M_z}{M_z \text{ Max}} \right) + \text{Load}_{\text{Radial}}$$

METRIC SERIES

PART NUMBER	MAX SPEED (m/min)	MAX SPEED (m/s)	Cd (N)
RR30	300	5.0	1,440
RR45	420	7.0	4,404
RR65	480	8.0	10,200

REDUCTION FACTOR

NOTE: Reduction factors apply to both inch and metric series

RF = Reduction Factor of the Application or Environment

- = 1.0 to 1.5 for very clean, low speed (<30% Max), low shocks
- = 1.5 to 2.0 for some dirtiness, moderate speed (30% Max to 75% Max), medium shocks and vibration
- = 2.0 to 3.0 for heavy dirt & dust, high speeds (>75% Max) and heavy shocks & vibrations

LOAD COMPARISON GRAPHS

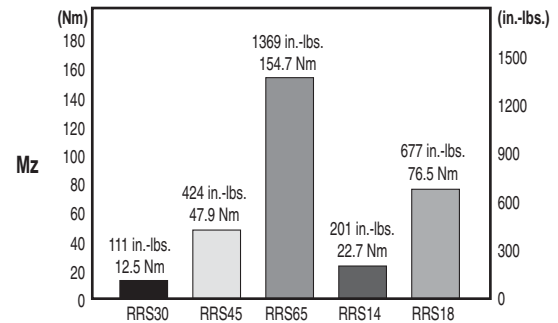
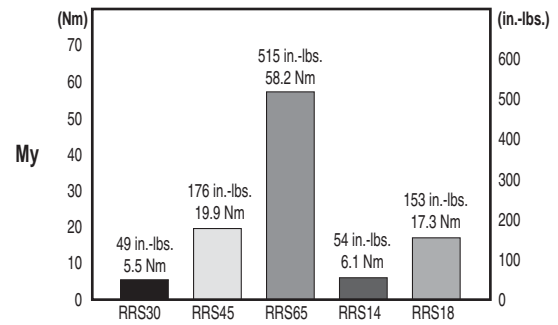
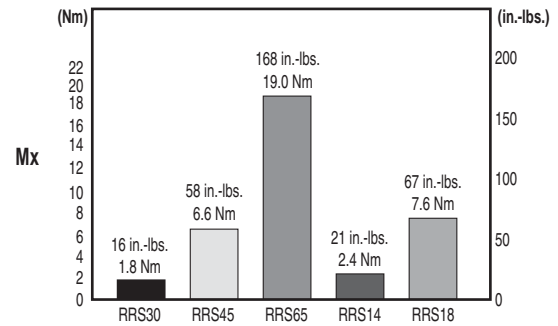
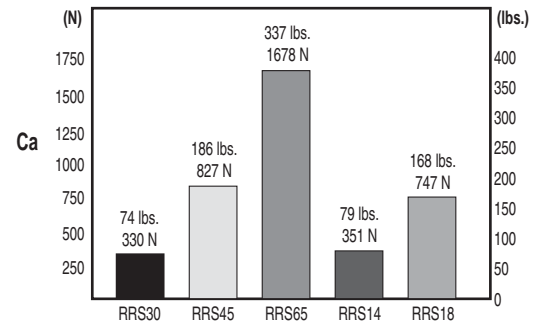
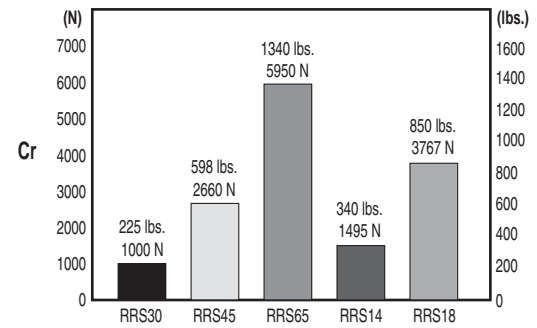

The data and specifications in this publication have been carefully compiled and are believed to be accurate and correct. However, it is the responsibility of the user to determine and ensure the suitability of Pacific Bearing® products for a specific application. Pacific Bearing's only obligation will be to repair or replace without charge, any defective components if returned promptly. No liability is assumed beyond such replacement. *Consult www.pacific-bearing.com for the latest technical updates.



RRS14



CHARACTERISTICS

- Low Cost Precision
- Factory Adjusted
- Sealed Bearings
- Solid Bearing Mounting System
- 5.79m Lengths
- Gothic Arch Rollers
- Off the Shelf Delivery

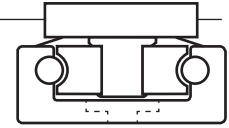

FEATURES

- Body is aluminum alloy.
- Rollers are 52100 steel, sealed against contamination, and are mounted with hardened steel mounting accessories.
- Not available with seals.
- Maximum temperature approximately 180°F.
- **NEW coated Redi-Rail FDA compliant, call 800-962-8979 for details.**

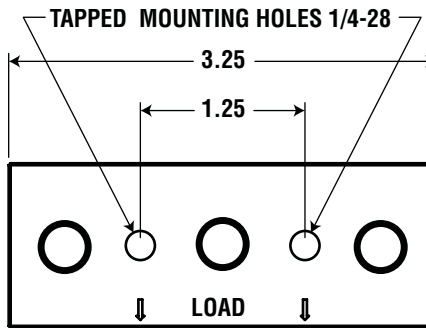
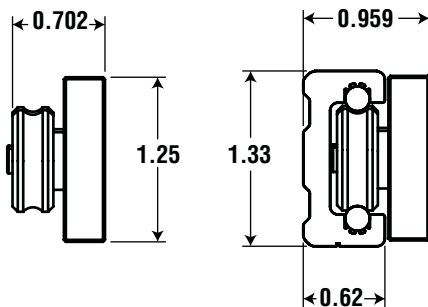

NOTE: Slide weight 0.25 lbs./ea.

ORDER INFORMATION



EXAMPLE:
RRS14 - Redi-Rail Slider size 14

REDI-RAIL Slide

Nominal Size

14 = Dimension

18 = Dimension (page 204)

The data and specifications in this publication have been carefully compiled and are believed to be accurate and correct. However, it is the responsibility of the user to determine and ensure the suitability of Pacific Bearing® products for a specific application. Pacific Bearing's only obligation will be to repair or replace without charge, any defective components if returned promptly. No liability is assumed beyond such replacement. *Consult www.pacific-bearing.com for the latest technical updates.



Redi-Rail® Linear Guides

RR14 Rails (Inch) - Load Capacity to 340 lbs.

Linear Motion Systems

RR14



Aluminum alloy with hardened steel reaway inserted.

LIFE CALCULATIONS

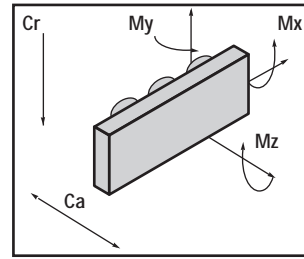

Cd = Dynamic capacity (LC)
 Cr = Radial capacity
 Ca = Axial capacity
 Mx, My, Mz = Moment capacities

Conversions

newton (N) x 0.2248 = lbs.
 (lbf) meter x 0.0397 = inch
 newton - meter (Nm) x 8.851 = in.-lbs.

PART NUMBER	Cd (lbs.)	Cr (lbs.)	Ca (lbs.)	Mx (in.-lbs.)	My (in.-lbs.)	Mz (in.-lbs.)
RRS14	421	340	79	21	54	201

SUGGESTED RAIL LENGTHS & DIMENSIONS (Inches)

PART NUMBER	LENGTH	HOLES	Y	WT. (lbs./ft.)
RR14-12	12	4	0.75	0.64
RR14-24	24	7	1.50	
RR14-36	36	11	0.50	
RR14-48	48	14	1.25	
RR14-60	60	17	2.00	
RR14-72	72	21	1.00	
RR14-84	84	24	1.75	
RR14-96	96	28	0.75	

NOTE: Suggested lengths can be cut and are available up to 19' (6m).

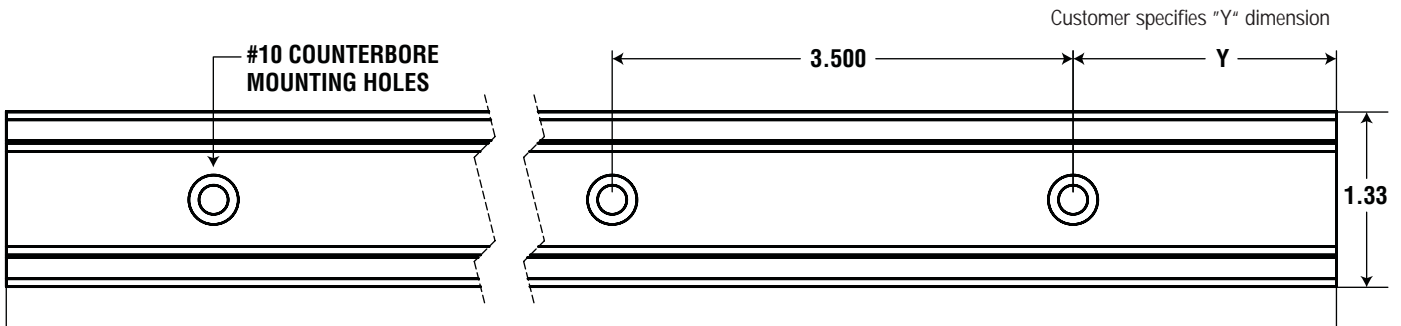

RR14

ORDER INFORMATION

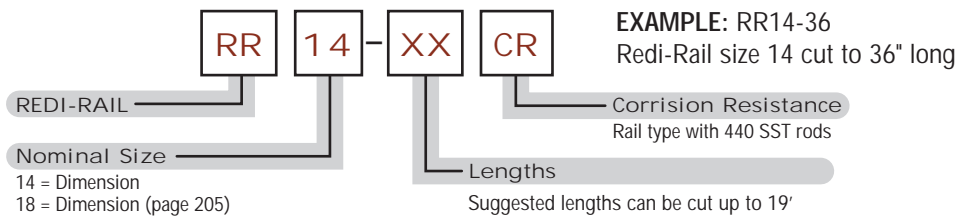

The data and specifications in this publication have been carefully compiled and are believed to be accurate and correct. However, it is the responsibility of the user to determine and ensure the suitability of Pacific Bearing® products for a specific application. Pacific Bearing's only obligation will be to repair or replace without charge, any defective components if returned promptly. No liability is assumed beyond such replacement. *Consult www.pacific-bearing.com for the latest technical updates.



Redi-Rail® Linear Guides

RRS18 Slides (Inch)

RRS18



CHARACTERISTICS

- Low Cost Precision
- Factory Adjusted
- Sealed Bearings
- Solid Bearing Mounting System
- 5.79m Lengths
- Gothic Arch Rollers
- Off the Shelf Delivery

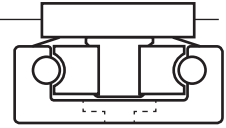

FEATURES

- Body is aluminum alloy.
- Rollers are 52100 steel, sealed against contamination, and are mounted with hardened steel mounting accessories.
- Not available with seals.
- Maximum temperature approximately 180°F.
- **NEW** coated Redi-Rail FDA compliant, call 800-962-8979 for details.

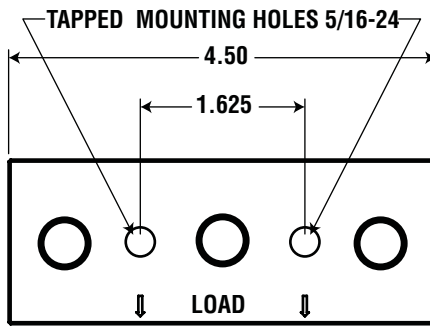
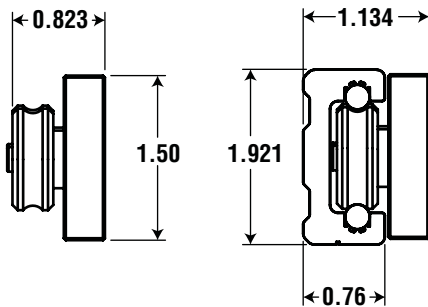

NOTE: Slide weight 0.50 lbs./ea.

ORDER INFORMATION



EXAMPLE:
RRS18 - Redi-Rail Slider size 18

REDI-RAIL Slide

Nominal Size

14 = Dimension (page 202)
18 = Dimension

The data and specifications in this publication have been carefully compiled and are believed to be accurate and correct. However, it is the responsibility of the user to determine and ensure the suitability of Pacific Bearing® products for a specific application. Pacific Bearing's only obligation will be to repair or replace without charge, any defective components if returned promptly. No liability is assumed beyond such replacement. *Consult www.pacific-bearing.com for the latest technical updates.



Redi-Rail® Linear Guides

RR18 Rails (Inch) - Load Capacity to 850 lbs.

Linear Motion Systems

RR18



LIFE CALCULATIONS

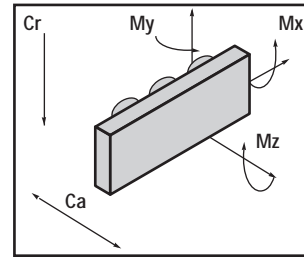

Cd = Dynamic capacity (LC)
 Cr = Radial capacity
 Ca = Axial capacity
 Mx, My, Mz = Moment capacities

Conversions

newton (N) x 0.2248 = lbs.
 (lbf) meter x 0.0397 = inch
 newton - meter (Nm) x 8.851 = in.-lbs.

PART NUMBER	Cd (lbs.)	Cr (lbs.)	Ca (lbs.)	Mx (in.-lbs.)	My (in.-lbs.)	Mz (in.-lbs.)
RRS18	1,032	850	168	67	153	677

SUGGESTED RAIL LENGTHS & DIMENSIONS (Inches)

PART NUMBER	LENGTH	HOLES	Y	WT. (lbs./ft.)
RR18-12	12	4	0.75	1.11
RR18-24	24	7	1.50	
RR18-36	36	11	0.50	
RR18-48	48	14	1.25	
RR18-60	60	17	2.00	
RR18-72	72	21	1.00	
RR18-84	84	24	1.75	
RR18-96	96	28	0.75	

NOTE: Suggested lengths can be cut and are available up to 19' (6m).

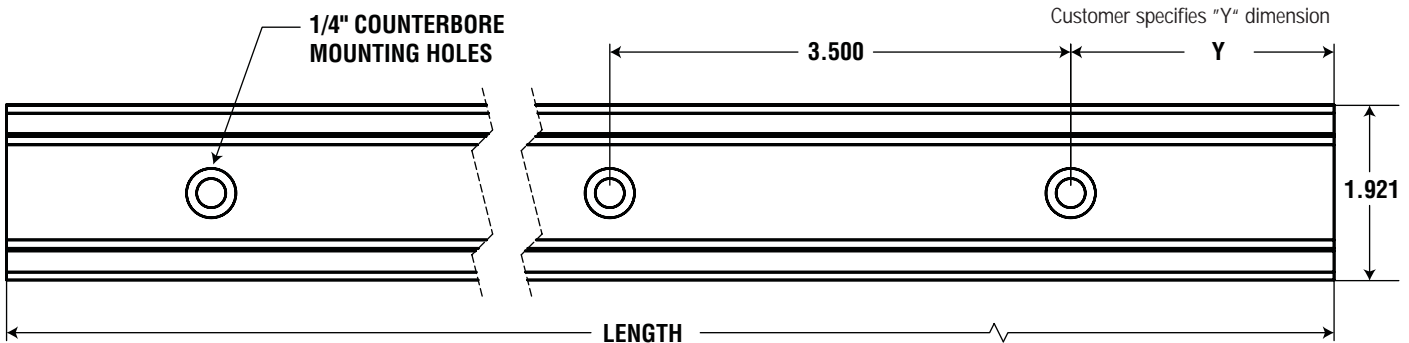

ORDER INFORMATION

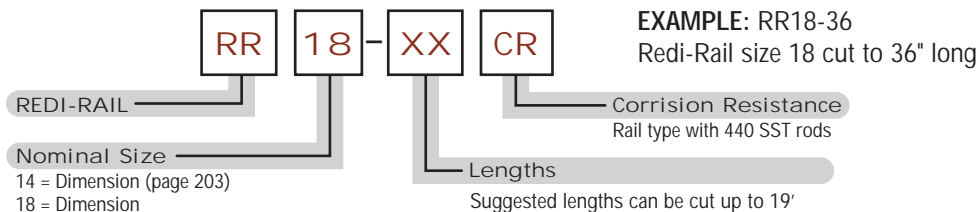

The data and specifications in this publication have been carefully compiled and are believed to be accurate and correct. However, it is the responsibility of the user to determine and ensure the suitability of Pacific Bearing® products for a specific application. Pacific Bearing's only obligation will be to repair or replace without charge, any defective components if returned promptly. No liability is assumed beyond such replacement. *Consult www.pacific-bearing.com for the latest technical updates.

RRS30



- Integral Seals
- Easy Adjusting

ROLLER/SHAFT INTERFACE

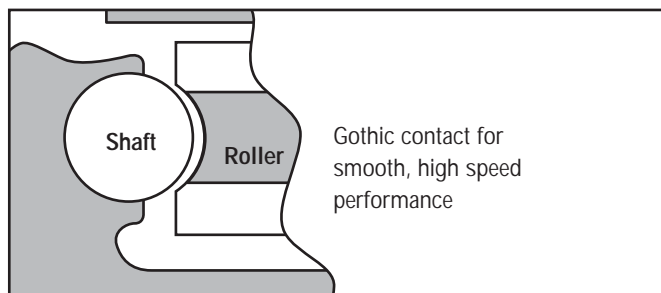

CHARACTERISTICS

- 5.79 Meter Lengths
- Sealed Bearings
- Off Shelf Delivery
- Gothic Arch Rollers
- Solid Roller Mounting

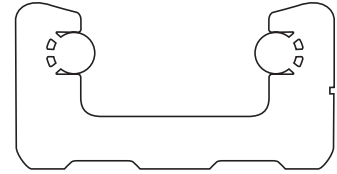

APPLICATIONS

- Automation
- Assembly
- Material Handling
- Packaging

FEATURES

- Slider body is aluminum alloy.
- Maximum temperature approximately 80°C.
- Gothic rollers are 52100 steel, hardened and ground, lubricated for life and sealed against contamination.
- Oil-filled plastic or UHMW spring loaded seals keep contamination clear of the rollers.
- Custom roller configurations can be designed, engineered, and manufactured to meet your specific requirements.
- Patented pre-load adjustment eliminates eccentrics.
- **NEW** coated Redi-Rail FDA compliant, call 800-962-8979 for details.

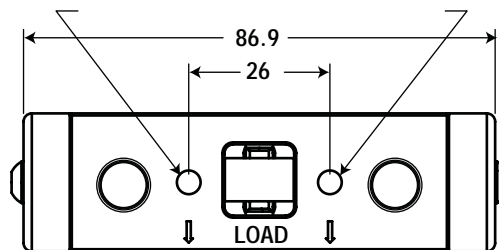
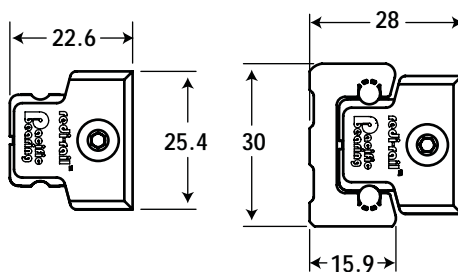

NOTE: Slide weight .09 Kg

ORDER INFORMATION

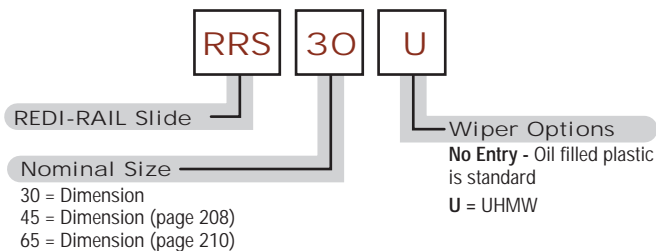

EXAMPLE: RRS30U

Redi-Rail Slider size 30 with UHMW seals

- NOTES:** Felt wipers have been replaced by low friction oil impregnated plastic wipers.
No entry in the part # results in use of oil impregnated wiper.

The data and specifications in this publication have been carefully compiled and are believed to be accurate and correct. However, it is the responsibility of the user to determine and ensure the suitability of Pacific Bearing® products for a specific application. Pacific Bearing's only obligation will be to repair or replace without charge, any defective components if returned promptly. No liability is assumed beyond such replacement. *Consult www.pacific-bearing.com for the latest technical updates.



RR30



- Rail is aluminum alloy with hardened and ground steel raceways inserted.
- Custom solutions can be designed, engineered, and manufactured to meet your specific requirements.
- Maximum lengths up to 5800mm are available.
- Patented preload adjustment
- Joinable for even longer runs.
- Cut-to-length

LIFE CALCULATIONS

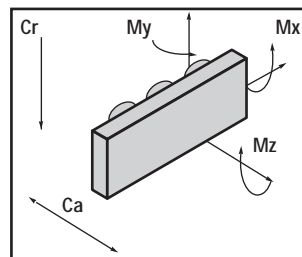

Cd = Dynamic capacity (LC)
 Cr = Radial capacity
 Ca = Axial capacity
 Mx, My, Mz = Moment capacities

Conversions

newton (N) x 0.2248 = lbs.
 (lbf) meter x 0.0397 = inch
 newton - meter (Nm) x 8.851 = in.-lbs.

PART NUMBER	Cd (N)	Cr (N)	Ca (N)	Mx (Nm)	My (Nm)	Mz (Nm)
RRS30	1,440	1,000	330	1.8	5.5	12.5

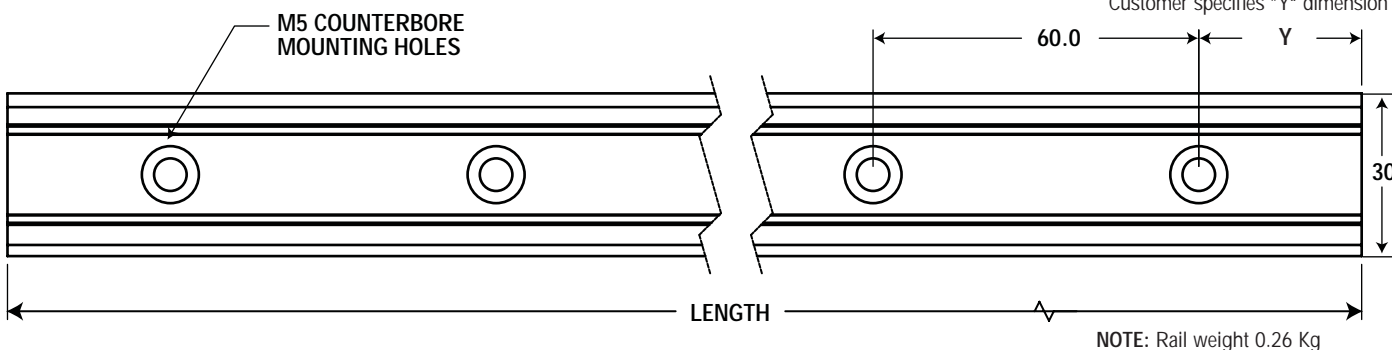

ORDER INFORMATION

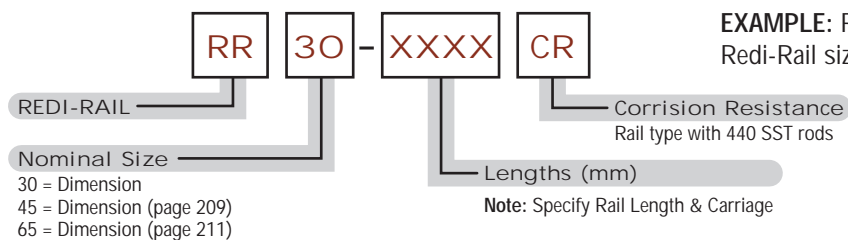

EXAMPLE: RR30-1200
 Redi-Rail size 30 cut to 1200mm long

The data and specifications in this publication have been carefully compiled and are believed to be accurate and correct. However, it is the responsibility of the user to determine and ensure the suitability of Pacific Bearing® products for a specific application. Pacific Bearing's only obligation will be to repair or replace without charge, any defective components if returned promptly. No liability is assumed beyond such replacement. *Consult www.pacific-bearing.com for the latest technical updates.

RRS45



- Integral Seals
- Easy Adjusting

ROLLER/SHAFT INTERFACE

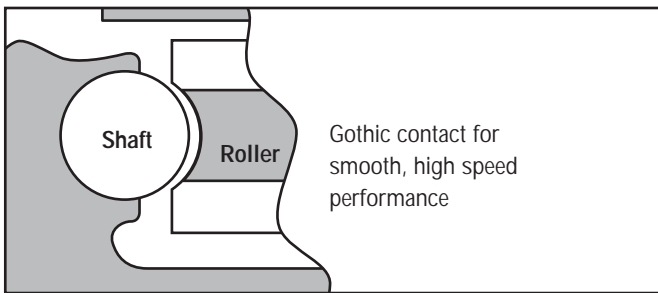

CHARACTERISTICS

- 5.79 Meter Lengths
- Sealed Bearings
- Off Shelf Delivery
- Gothic Arch Rollers
- Solid Roller Mounting

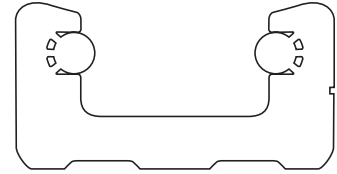

APPLICATIONS

- Automation
- Assembly
- Material Handling
- Packaging

FEATURES

- Slider body is aluminum alloy.
- Maximum temperature approximately 80°C.
- Gothic rollers are 52100 steel, hardened and ground, lubricated for life and sealed against contamination.
- Oil-filled plastic or UHMW spring loaded seals keep contamination clear of the rollers.
- Custom roller configurations can be designed, engineered, and manufactured to meet your specific requirements.
- Patented pre-load adjustment eliminates eccentrics.
- **NEW** coated Redi-Rail FDA compliant, call 800-962-8979 for details.

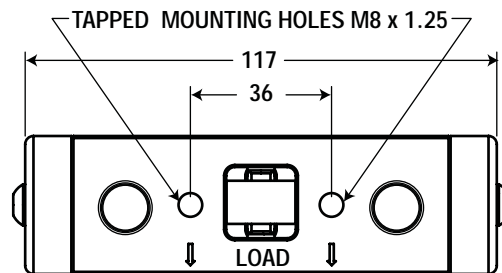
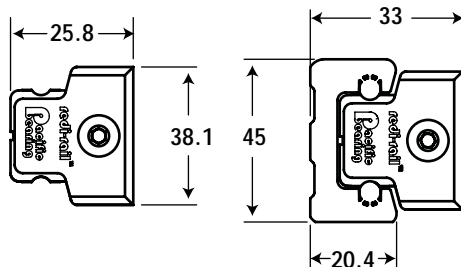

NOTE: Slide weight .23 Kg

ORDER INFORMATION

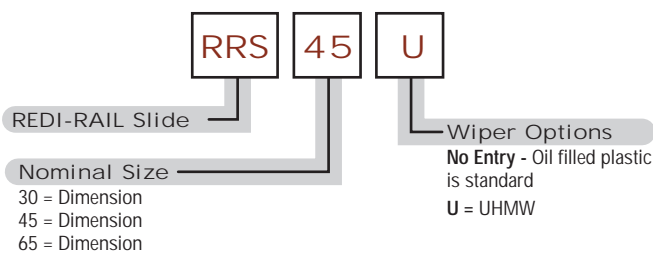

EXAMPLE: RRS45U

Redi-Rail Slider size 45 with UHMW seals

NOTES: Felt wipers have been replaced by low friction oil impregnated plastic wipers.
No entry in the part # results in use of oil impregnated wiper.

The data and specifications in this publication have been carefully compiled and are believed to be accurate and correct. However, it is the responsibility of the user to determine and ensure the suitability of Pacific Bearing® products for a specific application. Pacific Bearing's only obligation will be to repair or replace without charge, any defective components if returned promptly. No liability is assumed beyond such replacement. *Consult www.pacific-bearing.com for the latest technical updates.



RR45



- Rail is aluminum alloy with hardened and ground steel raceways inserted.
- Custom solutions can be designed, engineered, and manufactured to meet your specific requirements.
- Maximum lengths up to 5800mm are available.
- Patented preload adjustment
- Joinable for even longer runs.
- Cut-to-length

LIFE CALCULATIONS

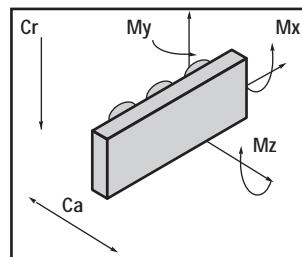

Cd = Dynamic capacity (LC)
 Cr = Radial capacity
 Ca = Axial capacity
 Mx, My, Mz = Moment capacities

Conversions
 newton (N) x 0.2248 = lbs.
 (lbf) meter x 0.0397 = inch
 newton - meter (Nm) x 8.851 = in.-lbs.

PART NUMBER	Cd (N)	Cr (N)	Ca (N)	Mx (Nm)	My (Nm)	Mz (Nm)
RRS45	4404	2660	827	6.6	19.9	47.9

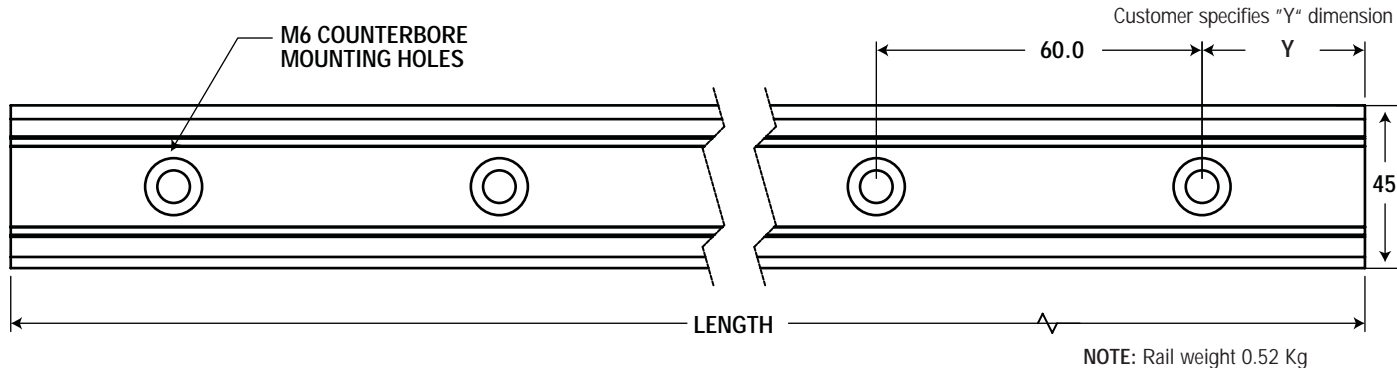

ORDER INFORMATION

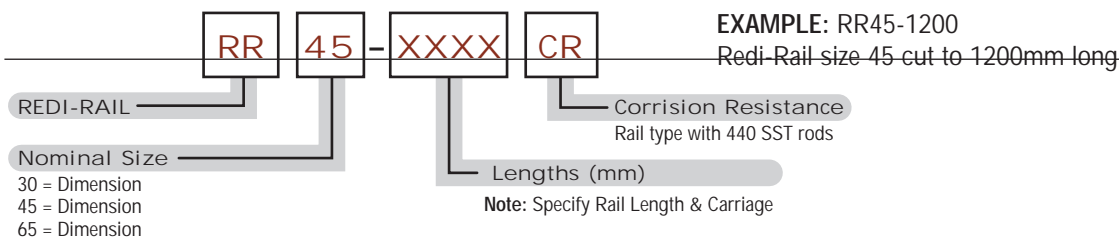

The data and specifications in this publication have been carefully compiled and are believed to be accurate and correct. However, it is the responsibility of the user to determine and ensure the suitability of Pacific Bearing® products for a specific application. Pacific Bearing's only obligation will be to repair or replace without charge, any defective components if returned promptly. No liability is assumed beyond such replacement. *Consult www.pacific-bearing.com for the latest technical updates.

RRS65



- Integral Seals
- Easy Adjusting

ROLLER/SHAFT INTERFACE

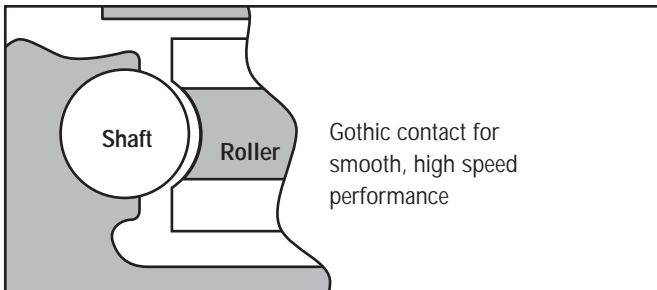

CHARACTERISTICS

- 5.79 Meter Lengths
- Sealed Bearings
- Off Shelf Delivery
- Gothic Arch Rollers
- Solid Roller Mounting

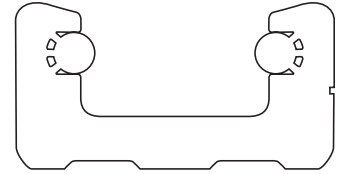

APPLICATIONS

- Automation
- Assembly
- Material Handling
- Packaging

FEATURES

- Slider body is aluminum alloy.
- Maximum temperature approximately 80°C.
- Gothic rollers are 52100 steel, hardened and ground, lubricated for life and sealed against contamination.
- Oil-filled plastic or UHMW spring loaded seals keep contamination clear of the rollers.
- Custom roller configurations can be designed, engineered, and manufactured to meet your specific requirements.
- Patented pre-load adjustment eliminates eccentrics.
- **NEW** coated Redi-Rail FDA compliant, call 800-962-8979 for details.

RRS65

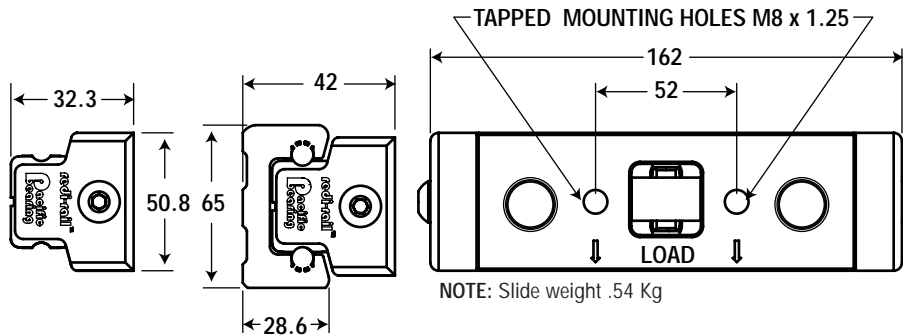

ORDER INFORMATION

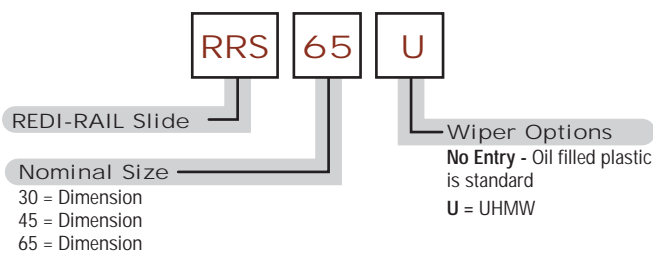

EXAMPLE: RRS65U

Redi-Rail Slider size 65 with UHMW seals

NOTES: Felt wipers have been replaced by low friction oil impregnated plastic wipers.
No entry in the part # results in use of oil impregnated wiper.

The data and specifications in this publication have been carefully compiled and are believed to be accurate and correct. However, it is the responsibility of the user to determine and ensure the suitability of Pacific Bearing® products for a specific application. Pacific Bearing's only obligation will be to repair or replace without charge, any defective components if returned promptly. No liability is assumed beyond such replacement. *Consult www.pacific-bearing.com for the latest technical updates.



Redi-Rail® Linear Guides

RR65 Rails (Metric) - Load Capacity up to 5,950 N

Linear Motion Systems

RR65



- Rail is aluminum alloy with hardened and ground steel raceways inserted.
- Custom solutions can be designed, engineered, and manufactured to meet your specific requirements.
- Maximum lengths up to 5800mm are available.
- Patented preload adjustment
- Joinable for even longer runs.
- Cut-to-length

LIFE CALCULATIONS

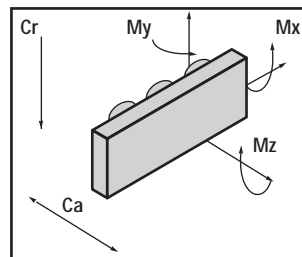

Cd = Dynamic capacity (LC)
 Cr = Radial capacity
 Ca = Axial capacity
 Mx, My, Mz = Moment capacities

Conversions
 newton (N) x 0.2248 = lbs.
 (lbf) meter x 0.0397 = inch
 newton - meter (Nm) x 8.851 = in.-lbs.

PART NUMBER	Cd (N)	Cr (N)	Ca (N)	Mx (Nm)	My (Nm)	Mz (Nm)
RRS65	10200	5950	1678	19.0	58.2	154.7

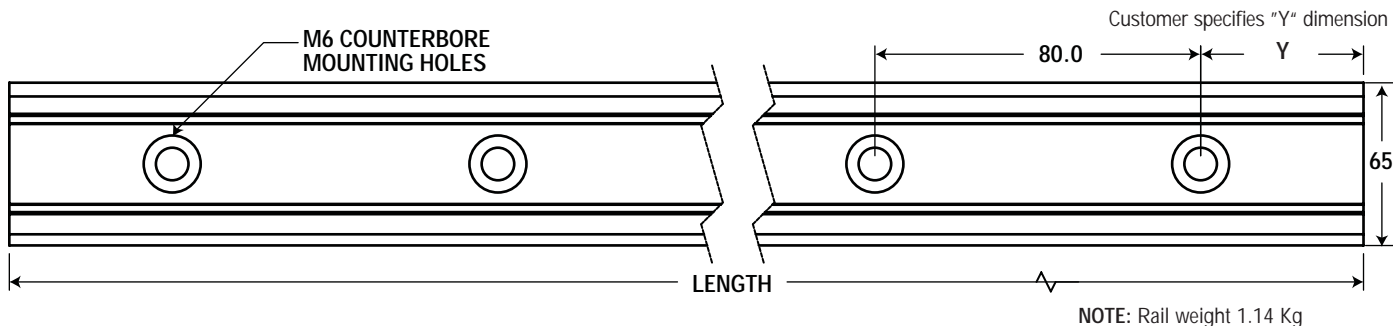

RR65

ORDER INFORMATION

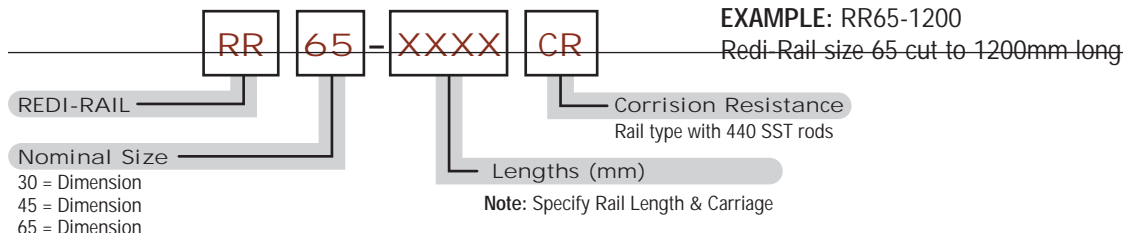

The data and specifications in this publication have been carefully compiled and are believed to be accurate and correct. However, it is the responsibility of the user to determine and ensure the suitability of Pacific Bearing® products for a specific application. Pacific Bearing's only obligation will be to repair or replace without charge, any defective components if returned promptly. No liability is assumed beyond such replacement. *Consult www.pacific-bearing.com for the latest technical updates.

PRODUCT OVERVIEW & APPLICATION



- Strokes range from 16" to 48"
- S shape stainless steel frame ensures heavy duty telescoping application
- Preloaded Redi-Rail assures precision movement
- Follow instructions on how to mount left-handed or right-handed section

Materials: Carbon steel rollers
300 series stainless steel roller shafts
300 series stainless steel frame
Santoprene bumpers
Anodized aluminum rail
Stainless steel hardware

Working Temperatures: -20C to 120C (-4F to 248F)

- Oil impregnated wipers not only prevents the system from dust and particle intrusion, but also provide lubrication and extend life cycles.
- Elastomer end stops are not intended as stroke terminus; hard stops must be provided to limit the stroke
- Load rated for a pair of slides when the load is applied on the middle of drawer beams. A load reduction factor shall be used if the load is applied toward the front of drawers.

3D models can be downloaded from our website at www.pacific-bearing.com.

NOTE: Load rated for a pair of slides when the load is applied on the middle of drawer beams. A load reduction factor shall be used if the load is applied toward the front of drawers.

PART NUMBER	LENGTH (in.)	STROKE (in.)	CAPACITY PER PAIR		MOUNTING DATA				SCREW SIZE FOR MOUNTING	H (in.)	W (in.)	M (in.)	WEIGHT (lbs.)
					A (in.)	B (in.)	C (in.)	QTY.					
RD30-0016	16.00	16.00	1,150 (N)	259 (lbs.)	1.25	2.36	0.58	7.00	(#10) M5	3.1	.83	1.39	4.85
RD30-0018	18.00	18.00	1,265	285	1.10	2.36	0.37	8.00	(#10) M5	3.1	.83	1.39	5.32
RD30-0024	24.00	24.00	1,391	313	1.25	2.36	1.49	12.00	(#10) M5	3.1	.83	1.39	7.27
RD30-0036	36.00	36.00	1,489	335	1.25	2.36	1.68	17.00	(#10) M5	3.1	.83	1.39	9.70
RD30-0048	48.00	48.00	1,542	347	1.25	2.36	1.87	21.00	(#10) M5	3.1	.83	1.39	12.13
RD45-0018	18.00	18.00	3,158	710	1.75	2.36	2.08	7.00	(1/4") M6	4.3	1.12	2.05	9.68
RD45-0024	24.00	24.00	3,673	826	1.38	2.36	1.36	12.00	(1/4") M6	4.3	1.12	2.05	13.23
RD45-0036	36.00	36.00	3,919	881	1.38	2.36	1.55	17.00	(1/4") M6	4.3	1.12	2.05	17.64
RD45-0048	48.00	48.00	4,061	913	1.38	2.36	1.74	21.00	(1/4") M6	4.3	1.12	2.05	22.05

ORDER INFORMATION

EXAMPLE: RDXX-XXXX-X

R = Right Hand
L = Left Hand

Size: 30, 45
Lengths (in.): 0016 (RD30), 0018, 0024, 0036, 0048

The data and specifications in this publication have been carefully compiled and are believed to be accurate and correct. However, it is the responsibility of the user to determine and ensure the suitability of Pacific Bearing® products for a specific application. Pacific Bearing's only obligation will be to repair or replace without charge, any defective components if returned promptly. No liability is assumed beyond such replacement. *Consult www.pacific-bearing.com for the latest technical updates.

PRODUCT OVERVIEW & APPLICATION



- Strokes range from 500mm to 1250mm
- S shape stainless steel frame ensures heavy duty telescoping application
- Preloaded Redi-Rail assures precision movement
- Follow instructions on how to mount left-handed or right-handed section

Materials: Carbon steel rollers
300 series stainless steel roller shafts
300 series stainless steel frame
Santoprene bumpers
Anodized aluminum rail
Stainless steel hardware

Working Temperatures: -20C to 120C (-4F to 248F)

- Oil impregnated wipers not only prevents the system from dust and particle intrusion, but also provide lubrication and extend life cycles.
- Elastomer end stops are not intended as stroke terminus; hard stops must be provided to limit the stroke
- Load rated for a pair of slides when the load is applied on the middle of drawer beams. A load reduction factor shall be used if the load is applied toward the front of drawers.

LOAD REDUCTION FACTOR VS. LOAD POSITION

3D models can be downloaded from our website at www.pacific-bearing.com.

NOTE: Load rated for a pair of slides when the load is applied on the middle of drawer beams. A load reduction factor shall be used if the load is applied toward the front of drawers.

PART NUMBER	LENGTH (mm)	STROKE (mm)	CAPACITY PER PAIR		MOUNTING DATA				SCREW SIZE FOR MOUNTING	H (mm)	W (mm)	M (mm)	.WEIGHT (kg)
					A (mm)	B (mm)	C (mm)	QTY.					
RRD30-0500	500	500	1,150 (N)	259 (lbs.)	50	60	30	8	M5	79	21.1	35.3	2.2
RRD30-0750	750	750	1,391	313	40	60	50	12	M5	79	21.1	35.3	3.3
RRD30-1000	1000	1000	1,489	335	30	60	10	17	M5	79	21.1	35.3	4.4
RRD30-1250	1,250	1,250	1,542	347	30	60	20	21	M5	79	21.1	35.3	5.5
RRD45-0500	500	500	2,871	645	50	60	30	8	M6	109	28.4	52.1	4.0
RRD45-0750	750	750	3,673	826	40	60	50	12	M6	109	28.4	52.1	6.0
RRD45-1000	1000	1000	3,919	881	30	60	10	17	M6	109	28.4	52.1	8.0
RRD45-1250	1,250	1,250	4,061	913	30	60	20	21	M6	109	28.4	52.1	10.0

ORDER INFORMATION

RRD

XX

XXXX

X

EXAMPLE: RRDXX-XXXX-X

REDI-RAIL DRAWER SLIDE

Size

30, 45

Lengths (mm)

0500, 0750, 1000, 1250

L = Left Hand
R = Right Hand

The data and specifications in this publication have been carefully compiled and are believed to be accurate and correct. However, it is the responsibility of the user to determine and ensure the suitability of Pacific Bearing® products for a specific application. Pacific Bearing's only obligation will be to repair or replace without charge, any defective components if returned promptly. No liability is assumed beyond such replacement. *Consult www.pacific-bearing.com for the latest technical updates.



Redi-Rail® Steel Linear Guides

Innovation in Roller-Based Linear Systems

Linear Motion Systems

IMPROVED LOAD CAPACITY

- double row precision ball-bearing rollers
- high load capacity, both radial and axial
- hardened and honed raceways

IMPROVED STIFFNESS

- optimised rail design
- roller bearings preloaded for stiffness

INCREASED SPEED AND LOWER NOISE

- high precision rollers
- super finished raceways
- low noise

EASY ASSEMBLY

- self-aligning and self-adjusting components, compensating for assembly/structural errors

GREAT DESIGN

- innovative and attractive look
- unique black finish

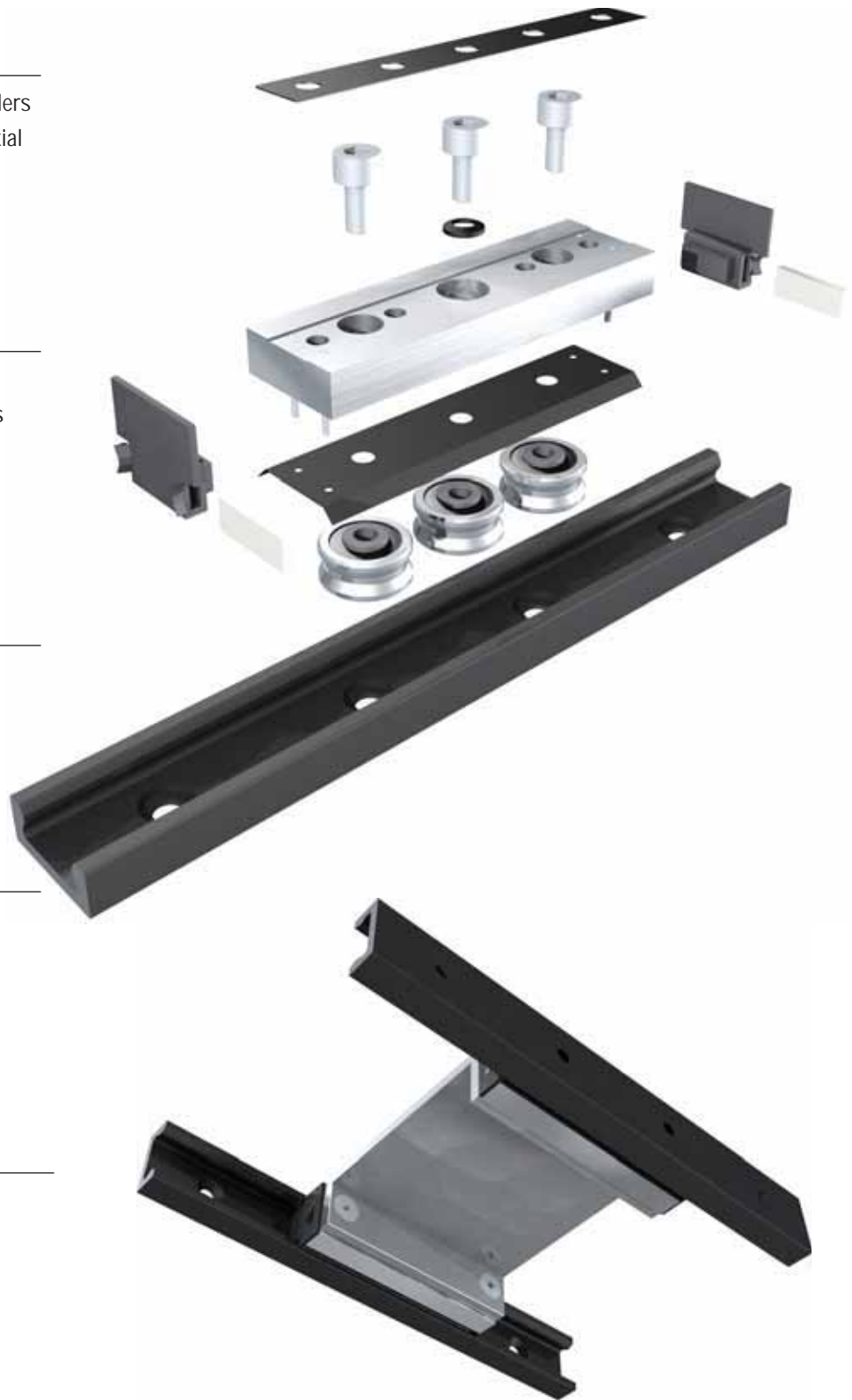

The data and specifications in this publication have been carefully compiled and are believed to be accurate and correct. However, it is the responsibility of the user to determine and ensure the suitability of Pacific Bearing® products for a specific application. Pacific Bearing's only obligation will be to repair or replace without charge, any defective components if returned promptly. No liability is assumed beyond such replacement. *Consult www.pacific-bearing.com for the latest technical updates.



IMPROVED LIFE TIME OF ALL COMPONENTS

- innovative materials
- innovative black surface hardening technology
- innovative wear resistance



IMPROVED CORROSION-RESISTANCE

- overall corrosion resistance, due to surface treatment, including raceways
- improved corrosion resistance compared traditional zinc plating

IMPROVED PROTECTION

- dust protection for the entire product range



LOW MAINTENANCE REQUIREMENTS

- self-lubricating system on all sliders and telescopic rails
- rollers lubricated for life



The data and specifications in this publication have been carefully compiled and are believed to be accurate and correct. However, it is the responsibility of the user to determine and ensure the suitability of Pacific Bearing® products for a specific application. Pacific Bearing's only obligation will be to repair or replace without charge, any defective components if returned promptly. No liability is assumed beyond such replacement. *Consult www.pacific-bearing.com for the latest technical updates.



SYSTEM LIFE



The actual lifetime of the system (rails, slides, and rollers) depends on the applied load, but is also influenced by factors such as: correct lubrication, environmental conditions, assembly precision to avoid uncalculated component stress/wear and total cycle length.

In order to estimate the expected system lifetime in km of operation, the following equation must be solved:

$$L(Km) = 100 \times (Co/P)^3 \times fc/n \times fa$$

Where:

Co = dynamic load coefficient of roller or slide

P = is the equivalent load applied on the heaviest loaded roller or slide.

For each single roller: $P = P_{rad} + (P_{ax} / Co_{ax}) \times Co_{rad}$

For the slide: $P = P_{rad} + (P_{ax} / Co_{ax} + M_x / Mo_x + M_y / Mo_y + M_z / Mo_z) \times Co_{rad}$

LINEAR PRECISION

The linear precision of the running slide depends on the rail and, specifically, on the longitudinal parallelism between the raceways and precision of the surface to which they are mounted.

As a result, two slide precision values are determined, one referring to the surface the rails is fixed to (A) and the other (B) to the precision of supporting rail.

Precision is achieved when the surfaces are aligned.

When all screws are correctly tightened, the RRT rail aligns with the fixing surface, and this adds up to the construction linear precision of the same rail.

When the RRT-rail is loose, it may result slightly curved. However, this does not give rise to any problem of alignment, once the rail is properly fixed.

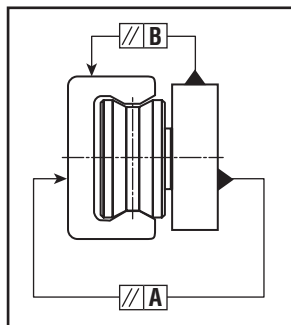

fc = coefficient depending on the actual length of the stroke. This is an important factor in the case of applications with short stroke and high frequency. In these cases total lifetime in km is much shorter, than if application with long strokes. The factor is equal to 1 for stroke longer than 2 meter, while for shorter than 2 meter, the value is derived from the graph shown below:

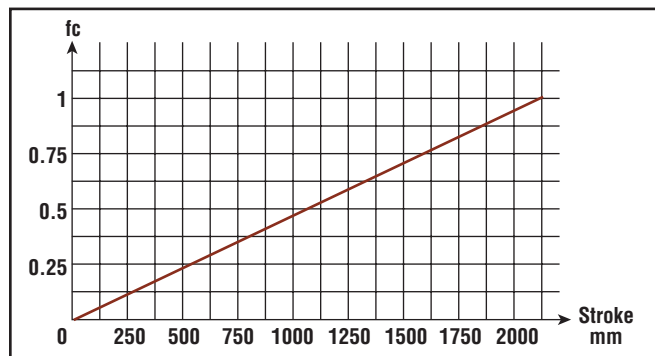

n = number of slides running on the same rail

fa = coefficient depending on lubrication and environmental conditions. Recommended values are shown in the table below:

fa	APPLICATION CONDITIONS
0.7 - 1	Good lubrication, availability of self-lubricating rail wiper system, no dust accumulation and no pollutants, precise assembly
0.5 - 0.7	Random lubrication, environmental dust, thermal fluctuations, vibrations
0.5 - 0.1	Low lubrication, high environmental pollution, strong thermal fluctuations, high vibrations

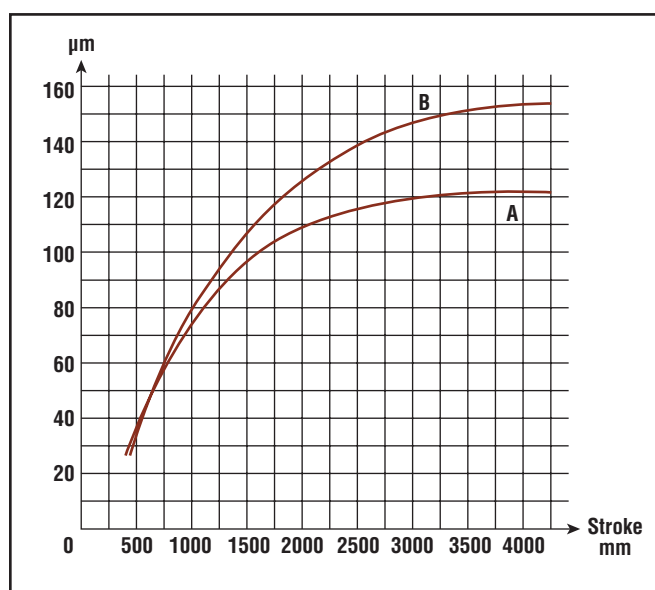

The data and specifications in this publication have been carefully compiled and are believed to be accurate and correct. However, it is the responsibility of the user to determine and ensure the suitability of Pacific Bearing® products for a specific application. Pacific Bearing's only obligation will be to repair or replace without charge, any defective components if returned promptly. No liability is assumed beyond such replacement. *Consult www.pacific-bearing.com for the latest technical updates.



SIZING CONTROL

When the positioning and configuration of rails and slides or rollers is determined, it is necessary to verify the correct sizing of system components, for both static and dynamic function. With regard to the static verification, it is necessary to determine the load applied onto each single slide. When the heaviest loaded slide is identified, the safety coefficient must be calculated on that slide and the result must be compared with the maximum static load capacity.

When the load applied is the result of a sum of radial and axial loads as well as moments, it is necessary to calculate the value of each component and verify the following:

$$\frac{Pax}{Co\ ax} + \frac{Prad}{Co\ rad} + \frac{Mx}{Mox} + \frac{My}{Moy} + \frac{Mz}{Moz} \leq \frac{1}{Z}$$

For system sizing of Steel Linear Slides, only the axial (Pax) and radial (Prad) load components must be taken into consideration. As a result, it is sufficient to calculate the following:

$$\frac{Pax}{Co\ ax} + \frac{Prad}{Co\ rad} \leq \frac{1}{Z}$$

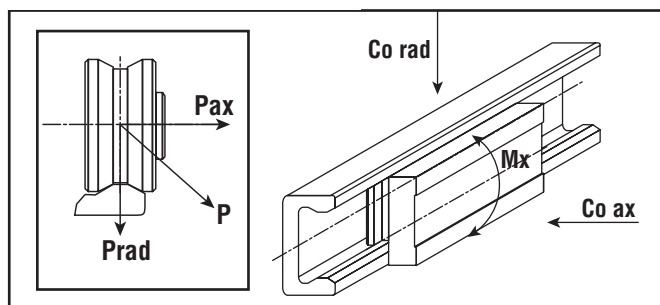

Where:

- Pax = axial load component
- Prad = radial load component
- Mx, My, Mz = applied moments
- Co ax = axial load capacity
- Co rad = radial load capacity
- Mox, Moy, Moz = resistance capacity to moments
- Z = safety coefficient ≥ 1

It is recommended to apply the following values to safety coefficient Z:

Z	APPLICATION CONDITIONS
1 - 1.5	Accurate determination of static and dynamic loads. Precise assembly, tight structure.
1.5 - 2	Average conditions
2 - 3.5	Insufficient determination of applied loads. Vibrations, loose structure. Imprecise assembly. Unfavourable environmental conditions.

The data and specifications in this publication have been carefully compiled and are believed to be accurate and correct. However, it is the responsibility of the user to determine and ensure the suitability of Pacific Bearing® products for a specific application. Pacific Bearing's only obligation will be to repair or replace without charge, any defective components if returned promptly. No liability is assumed beyond such replacement. *Consult www.pacific-bearing.com for the latest technical updates.

MAINTENANCE

The roller's internal elements are lubricated and protected by double lip seals (2RS). As a result, they are maintenance free.

The sliders of the Steel Linear Guide systems are equipped with lateral seals and a system of strong rail wipers, which incorporate a lubrication system, assuring a release of lubricating oil on the raceways overtime. This gives a maintenance free system for the entire lifetime, under normal clean operational environment.

A similar rail wiper and lubrication system is also standard assembled on the entire system of Drawer Slides of the Precision/RDR series.

In case the wipers with integrated lubrication system is disassembled, it is necessary to provide a periodic manual lubrication of the raceways, to assure a sufficient lubrication on the contact areas. In addition, it is also necessary to regularly clean the raceways for impurities or other residues.

For lubrication we recommend to apply standard lithium grease lubrication, specific for ball bearings.

CORROSION RESISTANCE

All Steel and Flexible rails have a surface treatment, which ensures the hardness and offers a high resistance to corrosion. As the surface treatment is carried out after working the raceways, the complete surface has a high corrosion protection also on the raceways. The treatment gives the rails an overall black finish.

In comparison to traditional electrolytic galvanization zinc plating, this surface treatment offer a much better corrosion resistance protection of the rails, which usually are more exposed to corrosion than the sliders.

All sliders and intermediate plate in RDR drawer slides have an electrolytic zinc plating surface treatment.

ADDITIONAL TECHNICAL INFORMATION

Any further technical product information or questions about their correct installation, may be requested from our Application Engineers.



Redi-Rail® Steel Linear Guides

RSS18 Slides & RRT18 Rails

Linear Motion Systems

RSS18 & RRT18

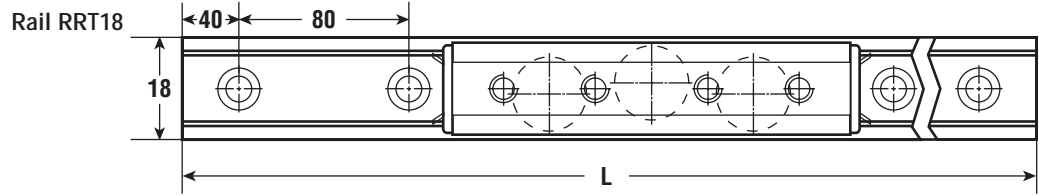

RAIL RRT18 LENGTHS																
160	240	320	400	480	560	640	720	800	880	960	1040	1120	1200	1280	1360	
1440	1520	1600	1680	1760	1840	1920	2000	2080	2160	2240	2320	2400	2480	2560	2640	
2720	2800	2880	2960													

Slides RSSV18-3

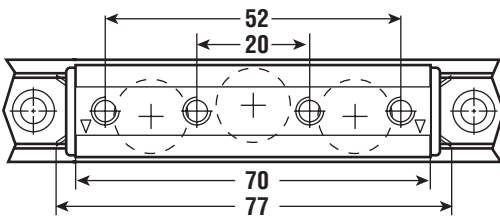

Slides RSSV18-5

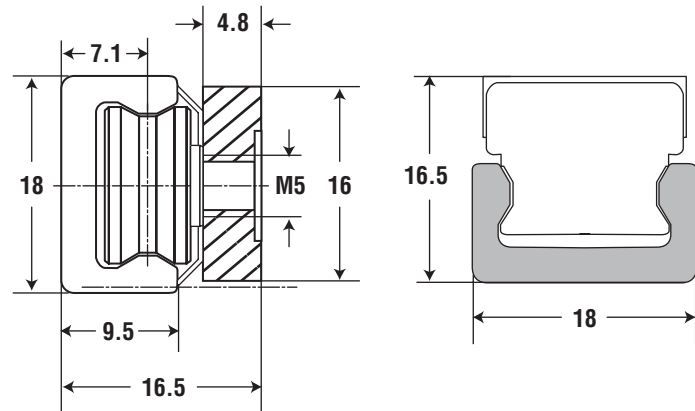
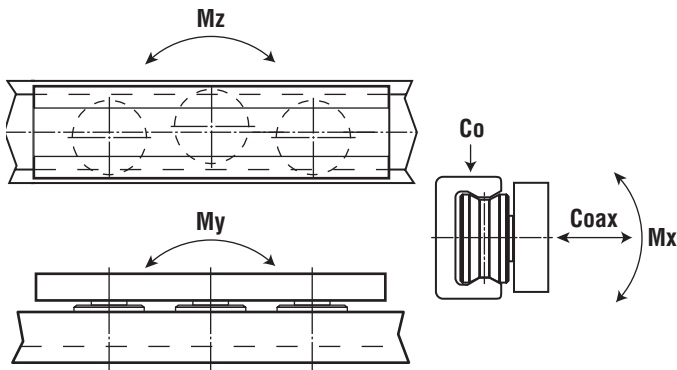
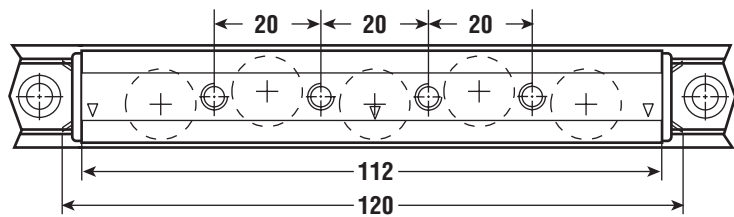

SLIDE TYPE	C (N)	RADIAL Co (N)	AXIAL Co (N)	Mx (Nm)	My (Nm)	Mz (Nm)
RSSX18-3	4,000	1,600	1,000	5.2	16.5	20
RSSX18-5	6,000	2,400	1,500	9.3	46.1	50.3

ORDER INFORMATION (SLIDE)

EXAMPLE: RSSV18-3

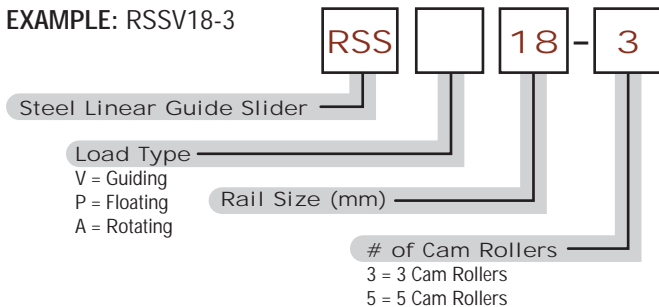

ORDER INFORMATION (RAIL)

EXAMPLE: RRT18-160

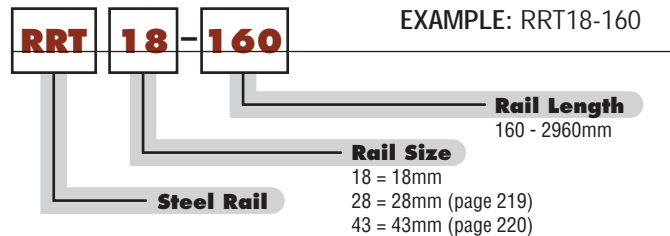

The data and specifications in this publication have been carefully compiled and are believed to be accurate and correct. However, it is the responsibility of the user to determine and ensure the suitability of Pacific Bearing® products for a specific application. Pacific Bearing's only obligation will be to repair or replace without charge, any defective components if returned promptly. No liability is assumed beyond such replacement. *Consult www.pacific-bearing.com for the latest technical updates.

RSS18 & RRT18



RSS28 & RRT28

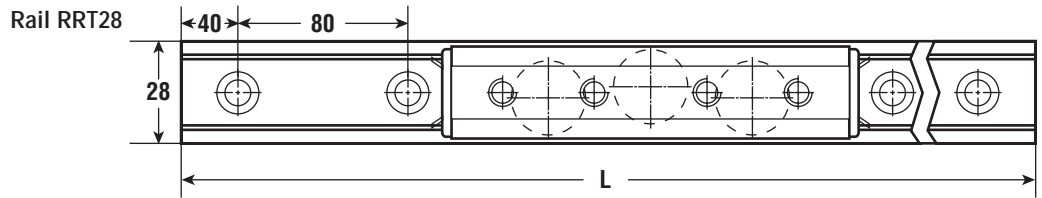

RAIL RRT28 LENGTHS															
240	320	400	480	560	640	720	800	880	960	1040	1120	1200	1280	1360	1440
1520	1600	1680	1760	1840	1920	2000	2080	2160	2240	2320	2400	2480	2560	2640	2720
2800	2880	2960	3040	3120	3200	3280	3360	3440	3520	3600	3680	3760	3840	3920	4000

Slides RSSV28-3

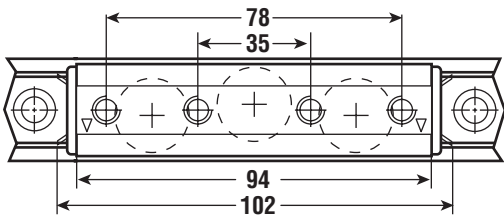

Slides RSSV28-5

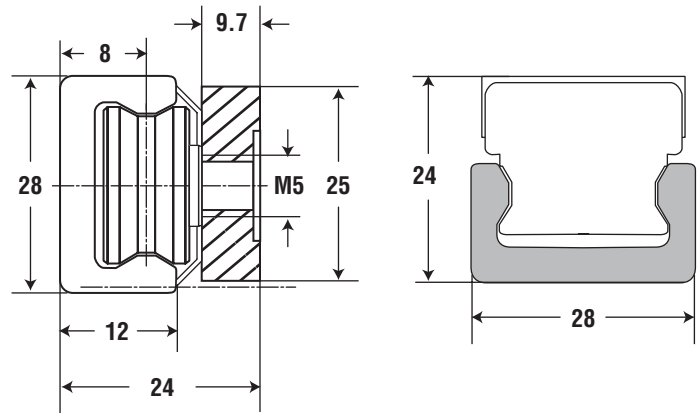
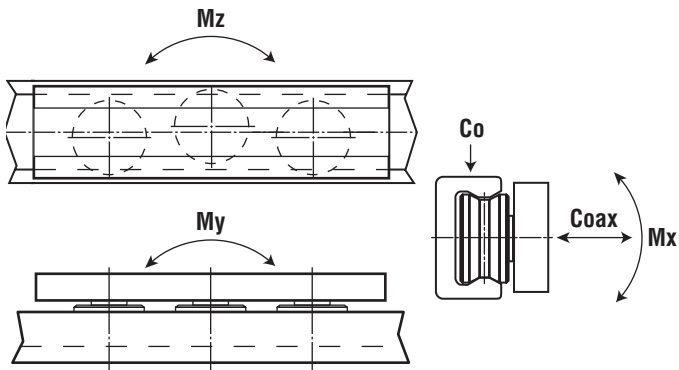
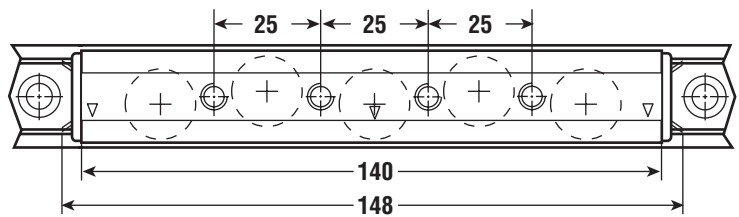

SLIDE TYPE	C (N)	RADIAL Co (N)	AXIAL Co (N)	Mx (Nm)	My (Nm)	Mz (Nm)
RSSX28-3	6,600	3,200	2,000	15.3	43.5	48
RSSX28-5	9,900	4,800	3,000	31.1	115.2	120

ORDER INFORMATION (SLIDE)

EXAMPLE: RSSV28-3

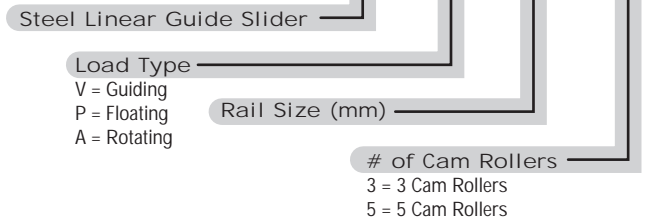

ORDER INFORMATION (RAIL)

EXAMPLE: RRT28-240

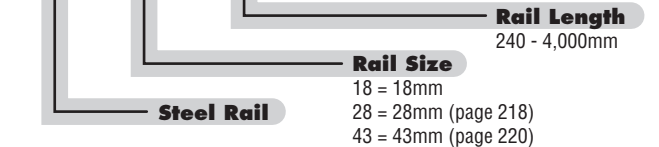

The data and specifications in this publication have been carefully compiled and are believed to be accurate and correct. However, it is the responsibility of the user to determine and ensure the suitability of Pacific Bearing® products for a specific application. Pacific Bearing's only obligation will be to repair or replace without charge, any defective components if returned promptly. No liability is assumed beyond such replacement. *Consult www.pacific-bearing.com for the latest technical updates.



Redi-Rail® Steel Linear Guides

RSS43 Slides & RRT43 Rails

Linear Motion Systems

RSS43 & RRT43

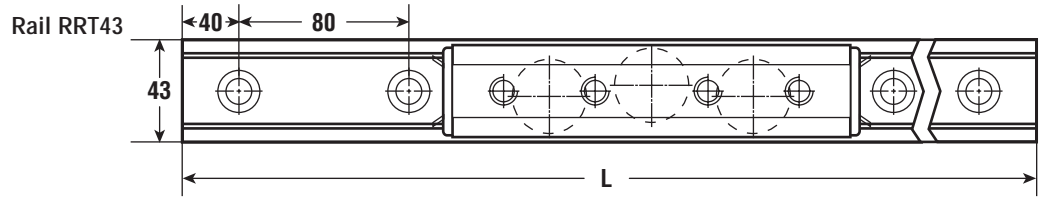

RAIL RRT43 LENGTHS															
400	480	560	640	720	800	880	960	1040	1120	1200	1280	1360	1440	1520	1600
1680	1760	1840	1920	2000	2080	2160	2240	2320	2400	2480	2560	2640	2720	2800	2880
2960	3040	3120	3200	3280	3360	3440	3520	3600	3680	3760	3840	3920	4000		

Slides RSSV43-3

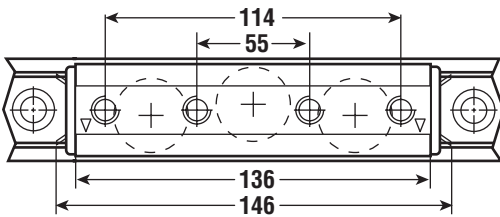

Slides RSSV43-5

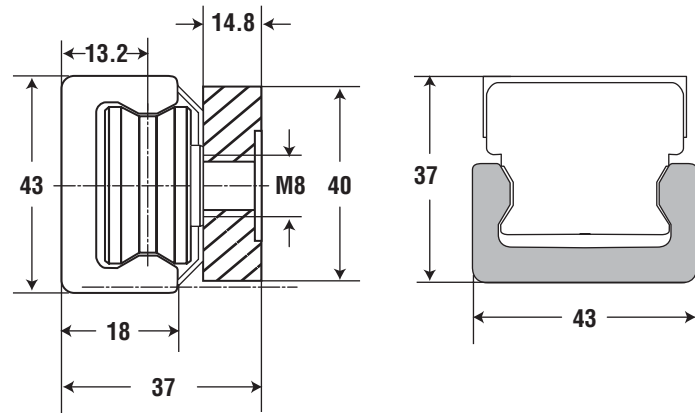
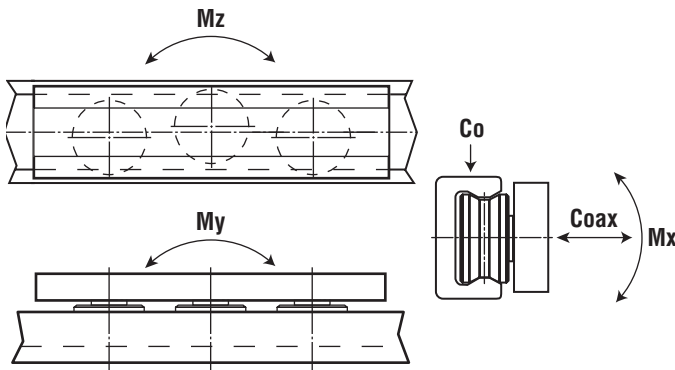
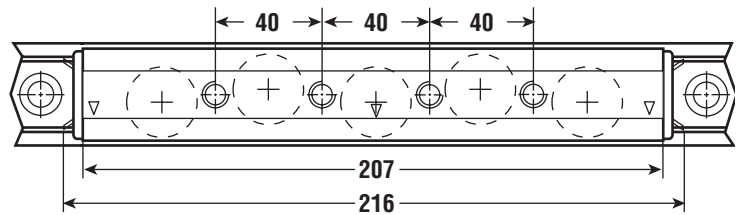

SLIDE TYPE	C (N)	RADIAL Co (N)	AXIAL Co (N)	Mx (Nm)	My (Nm)	Mz (Nm)
RSSX43-3	18,000	7,200	4,500	50.1	157.3	165
RSSX43-5	27,000	10,800	6,700	107.2	394	410

ORDER INFORMATION (SLIDE)

EXAMPLE: RSSV43-3

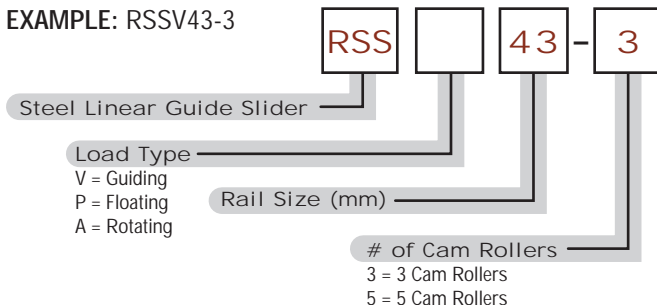

ORDER INFORMATION (RAIL)

EXAMPLE: RRT43-160

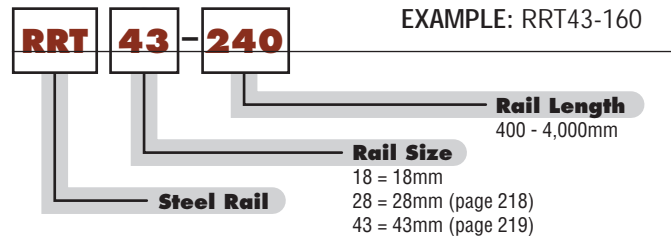

The data and specifications in this publication have been carefully compiled and are believed to be accurate and correct. However, it is the responsibility of the user to determine and ensure the suitability of Pacific Bearing® products for a specific application. Pacific Bearing's only obligation will be to repair or replace without charge, any defective components if returned promptly. No liability is assumed beyond such replacement. *Consult www.pacific-bearing.com for the latest technical updates.

RSS43 & RRT43



APPLICATIONS

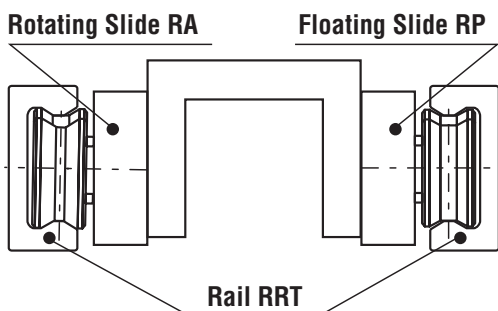

RAIL WITH FLOATING SLIDE RP SERIES

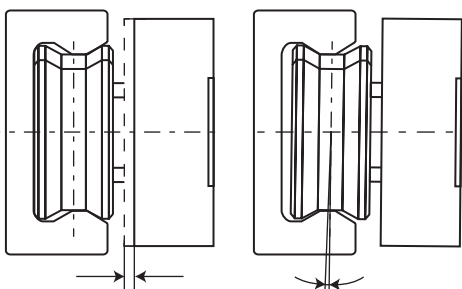

FLOATING SLIDE RP SERIES

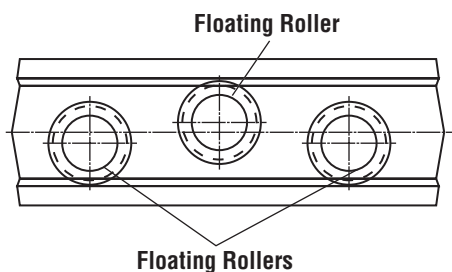

The "Floating" slides contain only floating rollers, three or five in total. The contact areas with the raceways only provide for radial load and M_z capacities, thus allowing for axial movement and a simultaneous slight rotation of the slide to offer axial and longitudinal compensation, while maintaining original preload and same precise and smooth straightline movement.

ROTATING SLIDE RA SERIES

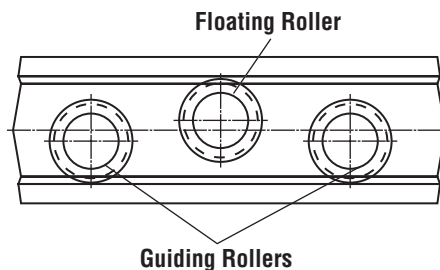

The "Rotating" slides are mounted with two or three guiding V-rollers (depending if slide has 3 or 5 rollers in total), which are aligned against the same lower raceway for max. radial load capacity. While one or two (depending if slide has three or five rollers in total) floating P rollers are mounted against the upper raceway. This configuration allows the A slide a minor rotation, around the contact points of the lower raceway. This compensates for axial misalignment, while maintaining its original preload and same straight, precision motion.

LONGITUDINAL PARALLELISM ERROR

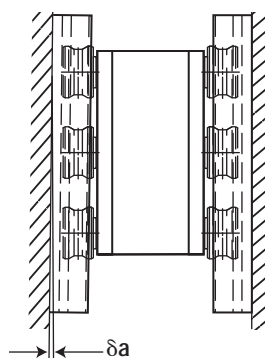

SIZE	δa
18	1mm
28	1.2mm
43	2mm

HORIZONTAL NON-ALIGNMENT ERROR

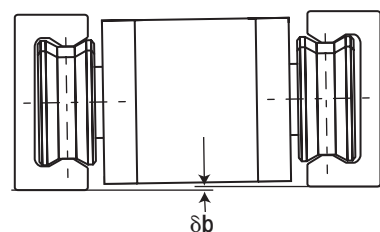

SIZE	δb
18	2°
28	2°
43	2°

HORIZONTAL PARALLELISM ERROR

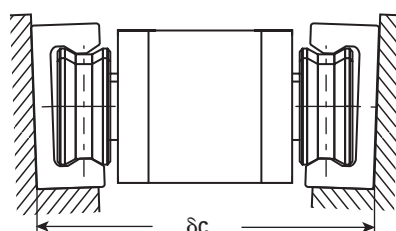

SIZE	δc
18	3°
28	3°
43	3°

The data and specifications in this publication have been carefully compiled and are believed to be accurate and correct. However, it is the responsibility of the user to determine and ensure the suitability of Pacific Bearing® products for a specific application. Pacific Bearing's only obligation will be to repair or replace without charge, any defective components if returned promptly. No liability is assumed beyond such replacement. *Consult www.pacific-bearing.com for the latest technical updates.



PRODUCT OVERVIEW

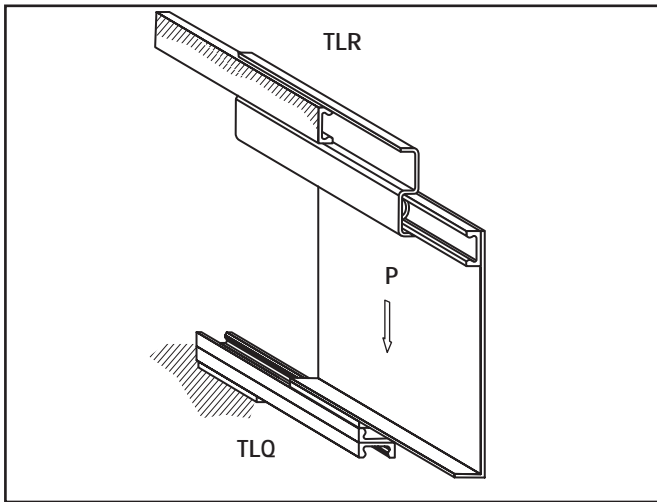

The Redi-Rail® Precision Drawer Slides & Redi-Rail® Compact Precision Drawer Slides systems are the world's only telescopic rail system for complete extension, based on precision rollers and hardened raceways and with incorporate self-aligning feature (RDR series).

The system offers unique possibilities for all kinds of automation applications, where smooth and precise telescopic movement is required. Optimal movement with no play for High-Tech telescopic applications, or for even heavy load and high frequency applications.

To guarantee high load capacities and low deflexion, the RDR drawer slides are fixed to an intermediate S-shaped steel plate.

The RDQ drawer slides have the RRT-rails functioning as the intermediate element, offering good radial and axial load capacities, with very compact overall dimensions.

the RDR and RDQ rails are the only drawer slide system which incorporates self-aligning feature to absorb parallelism errors of the mounting surfaces.

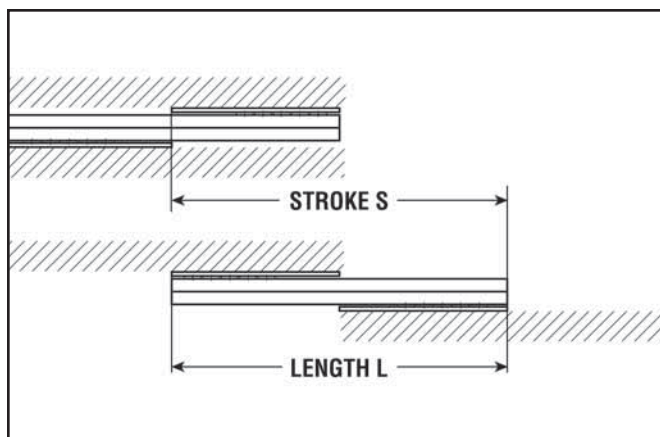
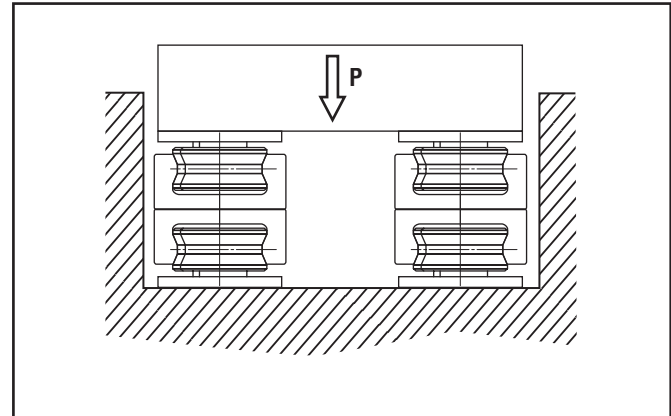

The Precision and Compact Precision systems are composed of exactly the same components as the Redi-Rail® Steel Rail system, except that the slider bodies are different, as longer and with more rollers. All drawer slides feature strong raceway wipers and greasing system for low maintenance.

The RDR drawer slides offer unique self-aligning capability, when used in pair. As the right telescopic rail RDRD, allows the sliders to rotate in the lower rail-element, to compensate assembling or surface misalignment errors, while maintaining the same precise, preloaded extension.

The data and specifications in this publication have been carefully compiled and are believed to be accurate and correct. However, it is the responsibility of the user to determine and ensure the suitability of Pacific Bearing® products for a specific application. Pacific Bearing's only obligation will be to repair or replace without charge, any defective components if returned promptly. No liability is assumed beyond such replacement. *Consult www.pacific-bearing.com for the latest technical updates.



PRODUCT OVERVIEW



The RDR Redi-Rail® Precision Drawer Slides are designed for heavy duty High-Tech telescopic applications, with precise motorized movement, requiring constant smooth sliding performance with no play.

The special smooth operating performance is due to double-row precision bearings strong rails with hardened and honed raceways, fixed to a rigid intermediate S-shaped steel plate, assuring high load capacities and low deflexion at even fully extended position.

The PBC drawer slides assure unique self-aligning capability, when used in pairs.

The right drawer slide RDRD, allows the slides to rotate with no play, in the lower rail-element to compensate for surface misalignments, while the rigid left RDRS drawer slide, maintains a stable and precise extension. The RDR or Redi-Rail® Precision drawer slide system offers unique

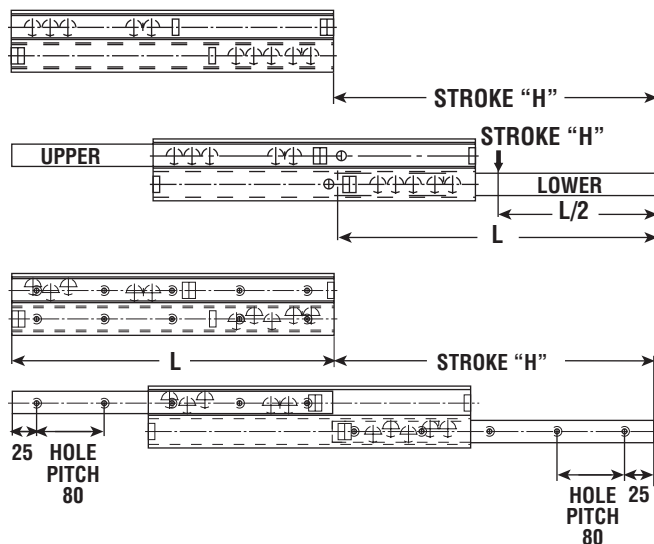

possibilities and benefits for all kind of automation applications with variable telescopic strokes, which until now have been troubled by common friction and breakdown problems, during the ball-cage rephasing when using of old-type ball-cage drawer slides. To assure maximum load

capacity the drawer slides must be correctly positioned according to the rollers' positioning, which are non-symmetric and with different position in upper – lower rail element.

Therefore the extended part must always be fixed to the lower rail. All Redi-Rail® Drawer Slides guarantee maintenance free operation, thanks to strong raceway wipers and longitudinal seals for dust and impurity protection, and an integrated lube for-life greasing system, assuring a constant thin layer of lubrication on the raceway surfaces.

All Redi-Rail® Precision Drawer Slides are equipped with internal end-stops, only designed to drag the intermediate element. It is therefore highly recommended not to use these internal ends- of stroke travel limits as functional terminals; strong external end-stops must be added. The Redi-Rail®

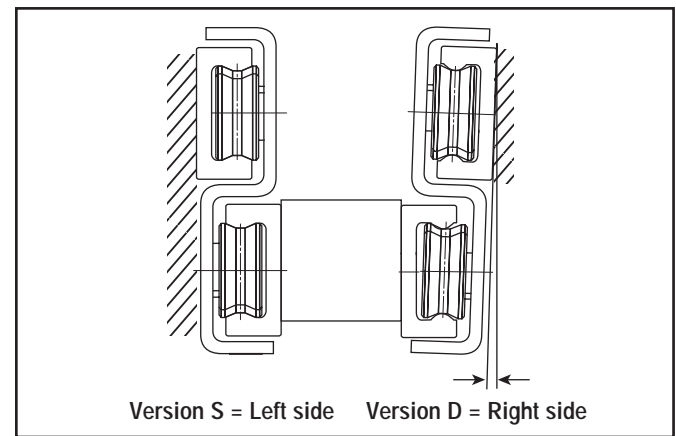
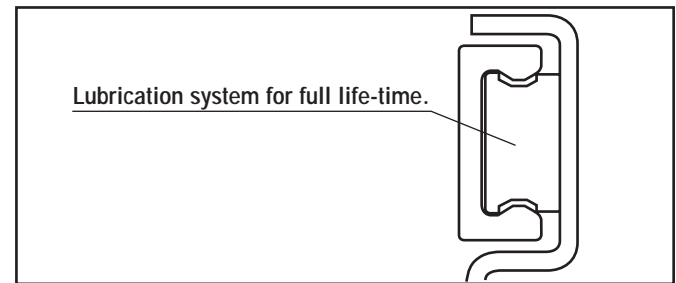

Precision Drawer Slides load capacities are intended at half extension (L/2) as indicated in by letter "P" in below drawing. Unlike ball-cages drawer slides, the Redi-Rail® Drawer Slides maximum load capacities are based on continuously non-stop operation.

Therefore a straight load comparison with other drawer slides isn't possible, as these load capacities are merely a static load capacity, based on low daily frequency. To offer a wide range of load capacities and extensions, the Redi-Rail® Drawer Slides come in 2 dimensions. The RDR80, based on 28mm rails with outer height of 80mm and RDR116, based on 43mm rails, with outer height of 116mm. Both rails come with an overall black finish.

The data and specifications in this publication have been carefully compiled and are believed to be accurate and correct. However, it is the responsibility of the user to determine and ensure the suitability of Pacific Bearing® products for a specific application. Pacific Bearing's only obligation will be to repair or replace without charge, any defective components if returned promptly. No liability is assumed beyond such replacement. *Consult www.pacific-bearing.com for the latest technical updates.



Redi-Rail® Precision Drawer Slides

RDRX80 & RDRX116

Linear Motion Systems

RDRX80

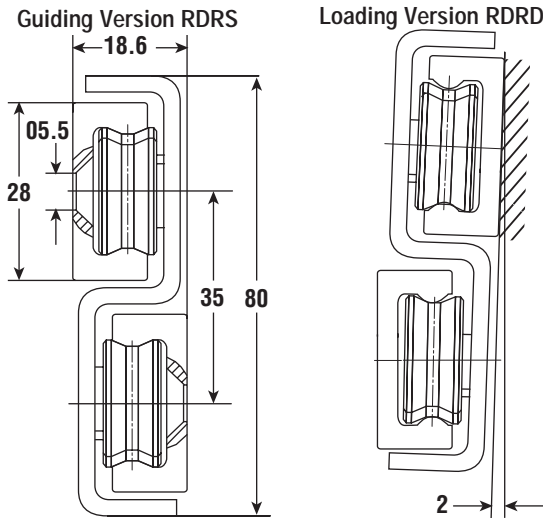

TYPE	STROKE H	LENGTH L	CO RAD (N)	(kg.)
RDRX80-0380	380	0370	753	2.1
RDRX80-0460	460	0450	817	2.5
RDRX80-0540	540	0530	1207	2.9
RDRX80-0620	620	0610	1495	3.3
RDRX80-0700	700	0690	1673	3.7
RDRX80-0780	780	0770	1771	4.1
RDRX80-0860	860	0850	1755	4.5
RDRX80-0940	940	0930	1623	4.9
RDRX80-1020	1020	1010	1510	5.3
RDRX80-1180	1180	1170	1325	6.1
RDRX80-1340	1340	1330	1180	6.9
RDRX80-1500	1500	1490	1064	7.7

NOTE: S = Left Side
D = Right Side

ORDER INFORMATION

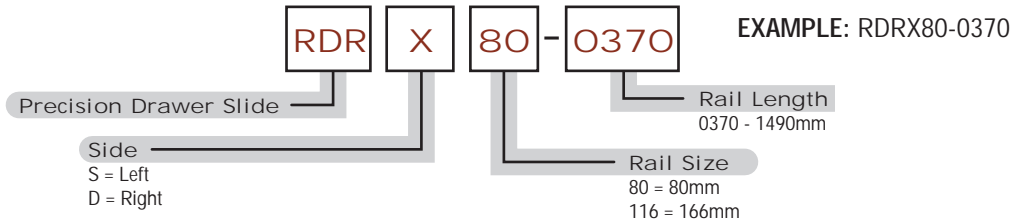

RDRX116

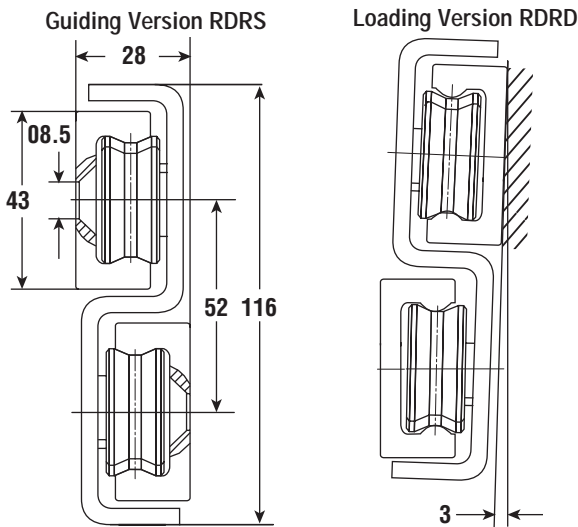

TYPE	STROKE H	LENGTH L	CO RAD (N)	(kg.)
RDRX116-0540	540	0530	1829	6.4
RDRX116-0620	620	0610	2040	7.3
RDRX116-0700	700	0690	2870	8.2
RDRX116-0780	780	0770	3033	9.1
RDRX116-0860	860	0850	3780	10.1
RDRX116-0940	940	0930	3978	11
RDRX116-1020	1020	1010	4122	11.8
RDRX116-1180	1180	1170	4080	13.6
RDRX116-1340	1340	1330	3648	15.4
RDRX116-1500	1500	1490	3298	17.1
RDRX116-1660	1660	1650	3010	18.9
RDRX116-1820	1820	1810	2768	20.7
RDRX116-1980	1980	1970	2562	22.4

NOTE: S = Left Side
D = Right Side

ORDER INFORMATION

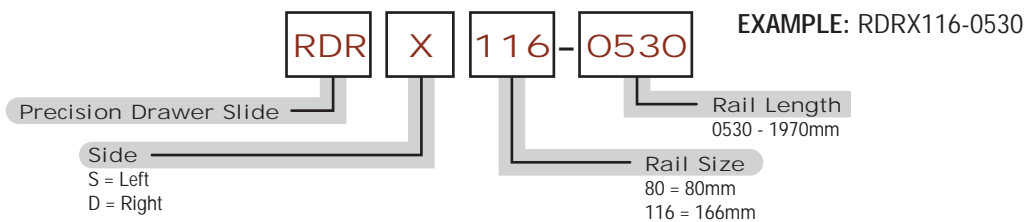

The data and specifications in this publication have been carefully compiled and are believed to be accurate and correct. However, it is the responsibility of the user to determine and ensure the suitability of Pacific Bearing® products for a specific application. Pacific Bearing's only obligation will be to repair or replace without charge, any defective components if returned promptly. No liability is assumed beyond such replacement. *Consult www.pacific-bearing.com for the latest technical updates.



PRODUCT OVERVIEW



The very compact RDO drawer slides are designed for High-Tech telescopic applications with precise motorized movement, requiring constant smooth sliding performance with no play.

The squared design is obtained by using two RRT-rails with hardened honed raceways, as the rigid intermediate element, into which the slides are assembled. The RDO drawer slides offer both high radial and axial load capacities.

The rail/slide configuration allows the RDO drawer slides to be mounted not only at the side, but also underneath the moving part, when there are space limitations at the sides, or to be used in typical vertical applications. See below tables and figures.

In the case of horizontal panel extension, we recommend the use of a pair of RDR and RDQ, as the RDR can absorb some lateral structural misalignments on the vertical axis.

RDO system assures smooth extension for all kinds of automation applications with variable telescopic strokes, which until now have been troubled by common friction breakdown problems, during the ball-cage rephasing, when using typical drawer slides. Same rephase problem or even deformation of the ball-cages, occurs for all vertical applications, as the ball-cage in such drawer slides, constantly tend to move downwards, so extra friction is generated with each stroke, during the repositioning of the ball-cages.

To assure maximum load capacity the drawer slides must be correctly orientation, assembled. The extended part must always be fixed to the shortest slide.

All Redi-Rail® Steel Rails guarantee maintenance free operation, thanks to strong raceway wipers and longitudinal seals for dust and impurity protection, and an integrated lubed for-life greasing system, assuring a constant thin layer of lubrication on the raceway surfaces.

All Redi-Rail® Compact Precision Drawer Slides are equipped with internal end-stops, only designed to drag the intermediate element. It is therefore highly recommended not to use these internal end of stroke travel limits as functional terminals; strong external end-stops must be added. Similarly to the RDR series, the RDQ's stroke goes slightly beyond the overall length of the rail in closed position. The rails come with an overall black finish.

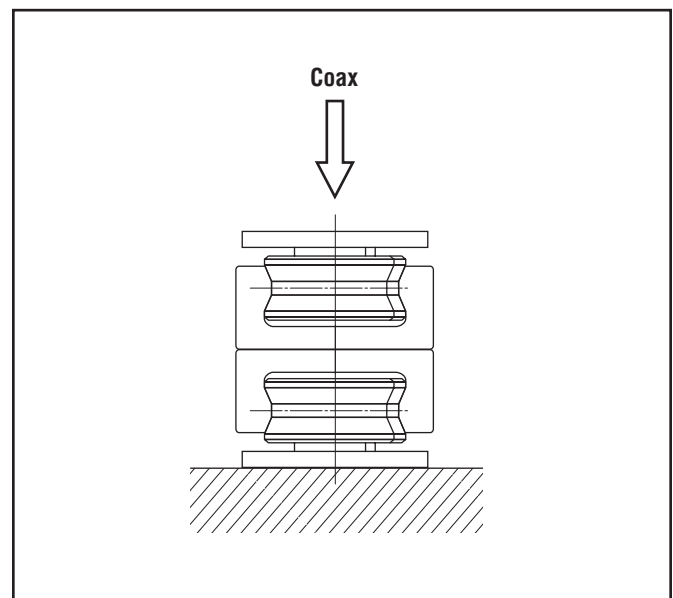
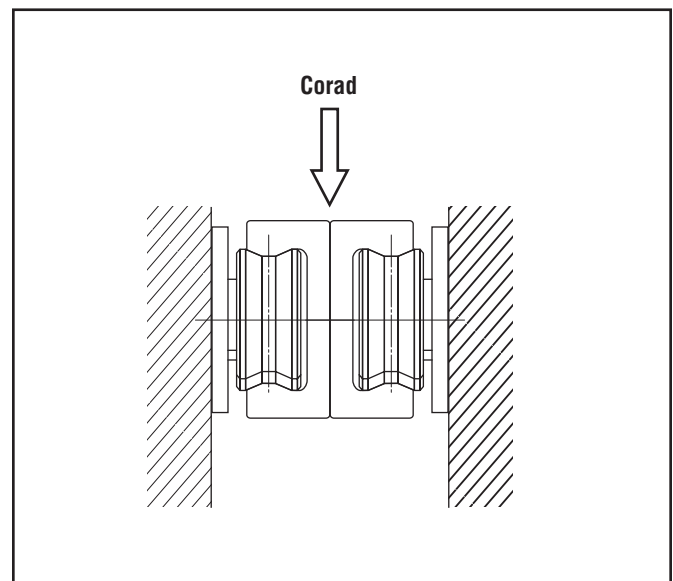

The data and specifications in this publication have been carefully compiled and are believed to be accurate and correct. However, it is the responsibility of the user to determine and ensure the suitability of Pacific Bearing® products for a specific application. Pacific Bearing's only obligation will be to repair or replace without charge, any defective components if returned promptly. No liability is assumed beyond such replacement. *Consult www.pacific-bearing.com for the latest technical updates.



RDQD37

All Redi-Rail Compact Precision rails guarantee maintenance free operation, thanks to strong raceway wipers and longitudinal seals for dust and impurity protection, and an integrated lubed for-life greasing system, assuring a constant thin layer of lubrication on the raceway surfaces.

All Redi-Rail Compact Precision rails are equipped with internal end-stops, only designed to drag the intermediate

element. It is therefore highly recommended not to use these internal end of stroke travel limits as functional terminals; strong external end-stops must be added. Similarly to the RDR series, the RDO's stroke goes slightly beyond the overall length of the rail in closed position. The rails come with an overall black finish.

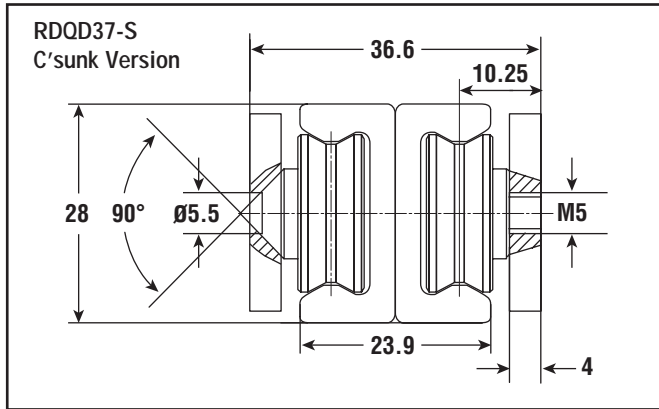

NOTE: To be used when fixing support (for fixed slide) is with threaded holes.

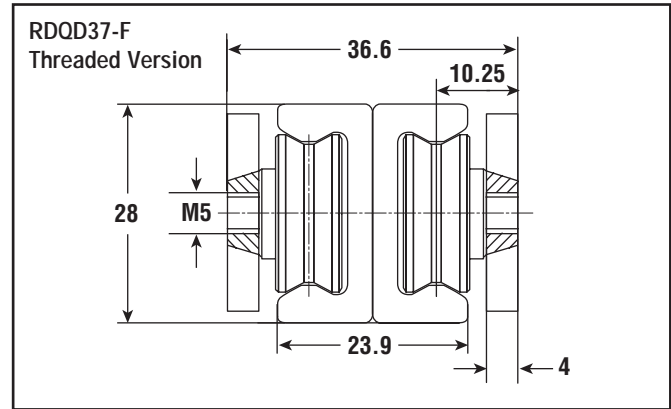

NOTE: To be used when fixing support (for fixed slide) is without threaded holes.

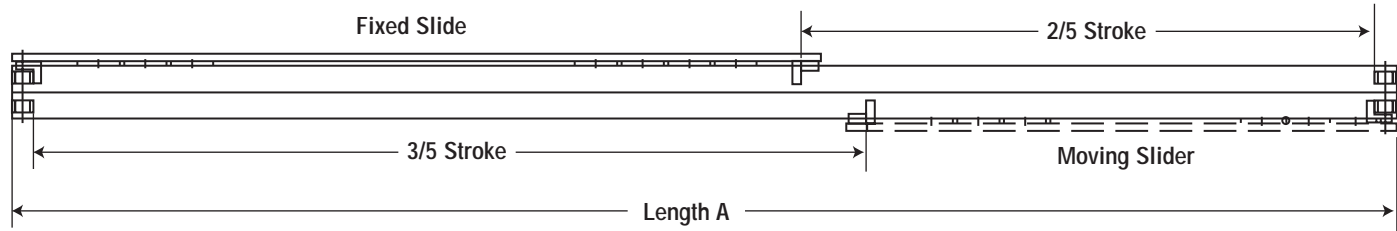

RDQD37

The data and specifications in this publication have been carefully compiled and are believed to be accurate and correct. However, it is the responsibility of the user to determine and ensure the suitability of Pacific Bearing® products for a specific application. Pacific Bearing's only obligation will be to repair or replace without charge, any defective components if returned promptly. No liability is assumed beyond such replacement. *Consult www.pacific-bearing.com for the latest technical updates.



RDOX37

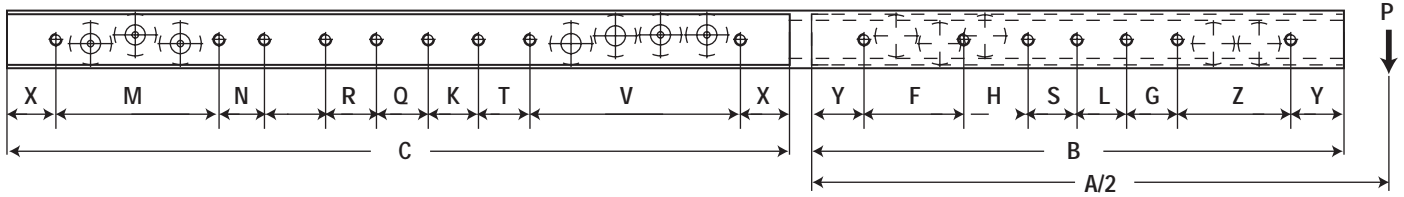

TYPE	STROKE	A	B	C	X	M	N	P	R	Q	K	T	Y	F	H	S	L	Z	CORAD (N)	COAX (N)	(kg.)	
RDOX37-0380	380	370	170	201	53	70	70	x	x	x	x	x	25	70	50	x	x	50	707	441	1.5	
RDOX37-0460	460	450	175	276		72	72	72					25	70	55			55	1003	655	1.7	
RDOX37-0540	540	530	207	324		88	88	88					23.5	80	80			80	1128	721	2.0	
RDOX37-0620	620	610	239	372		104	104	104					24.5	95	95			95	1116	689	2.3	
RDOX37-0700	700	690	271	420		120	120	120	25.5	110	110	110	1012	623	2.6							
RDOX37-0780	780	770	303	468		102	102	102	102	24	85	85	85	85	85	926	569	2.8				
RDOX37-0860	860	850	335	516		90	90	90	90	96	25	95	95	95	95	95	853	523	3.1			
RDOX37-0940	940	930	367	564		100	100	100	100	100	26	105	105	105	105	106	791	484	3.4			
RDOX37-1020	1020	1010	399	612		110	110	110	110	110	x	25.5	87	87	87	87	87	87	738	451	3.6	
RDOX37-1180	1180	1170	463	708		108	108	108	108	108	108	25.5	103	103	103	103	103	103	650	396	4.2	
RDOX37-1340	1340	1330	527	804		124	124	124	124	124	124	23.5	120	120	120	120	120	120	580	353	4.7	
RDOX37-1500	1500	1490	591	900		120	120	120	120	120	120	120	120	25.5	108	108	108	108	108	524	319	5.2

NOTE: S = Left Side
D = Right Side

Roller Positions: Ex. RDOX37 - 0380

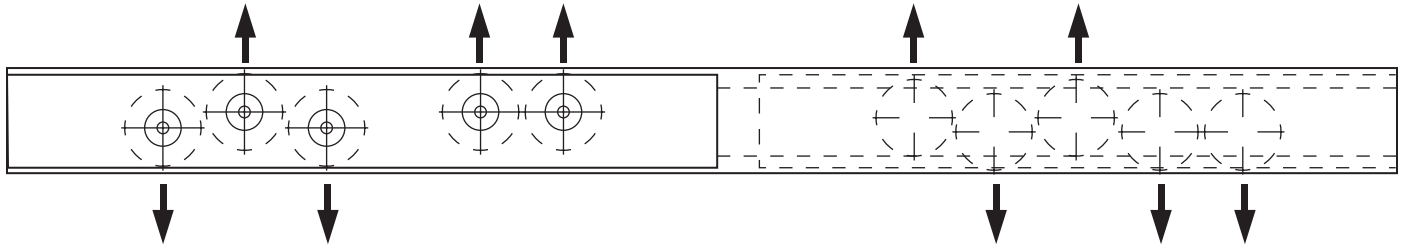

ORDER INFORMATION

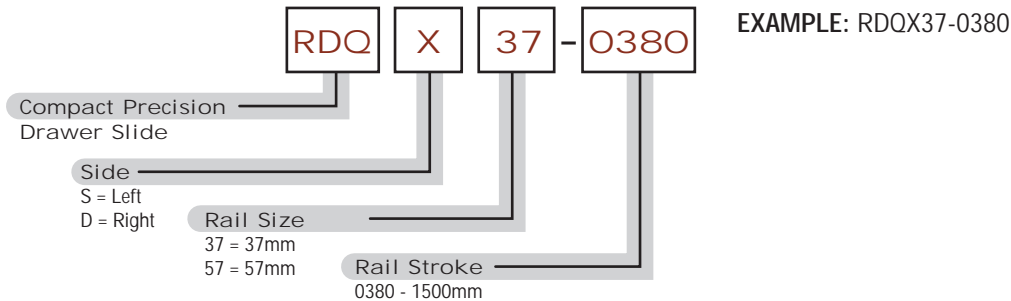

The data and specifications in this publication have been carefully compiled and are believed to be accurate and correct. However, it is the responsibility of the user to determine and ensure the suitability of Pacific Bearing® products for a specific application. Pacific Bearing's only obligation will be to repair or replace without charge, any defective components if returned promptly. No liability is assumed beyond such replacement. *Consult www.pacific-bearing.com for the latest technical updates.



RDQS57

All Redi-Rail Compact Precision rails guarantee maintenance free operation, thanks to strong raceway wipers and longitudinal seals for dust and impurity protection, and an integrated lubed for-life greasing system, assuring a constant thin layer of lubrication on the raceway surfaces.

All Redi-Rail Compact Precision rails are equipped with internal end-stops, only designed to drag the intermediate

element. It is therefore highly recommended not to use these internal end of stroke travel limits as functional terminals; strong external end-stops must be added. Similarly to the RDR series, the RDO's stroke goes slightly beyond the overall length of the rail in closed position. The rails come with an overall black finish.

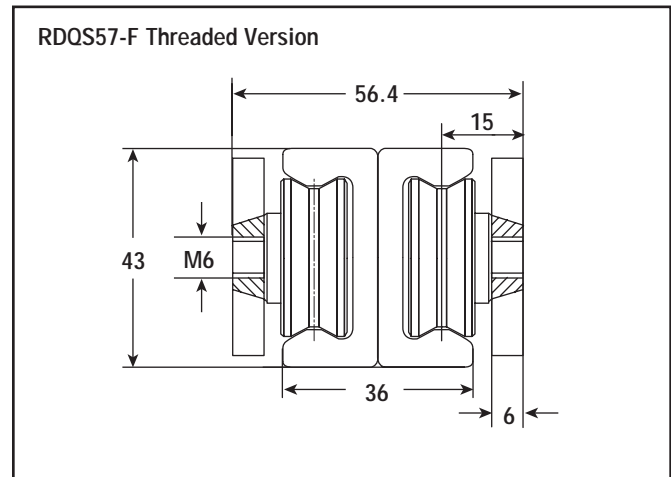
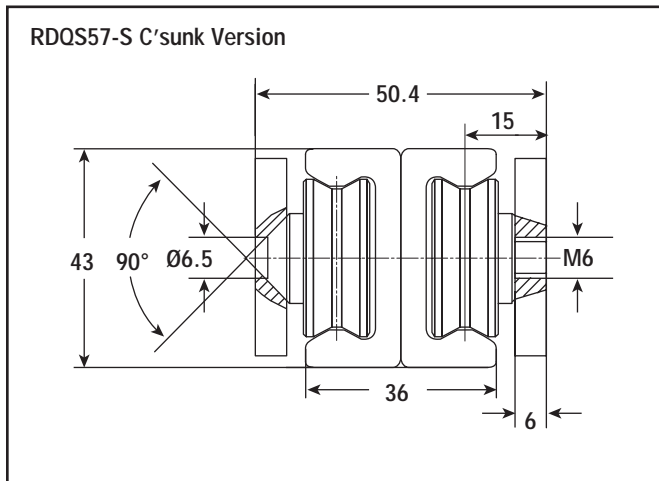

NOTE: To be used when fixing support (for fixed slide) is with threaded holes

NOTE: To be used when fixing support (for fixed slide) is without threaded holes

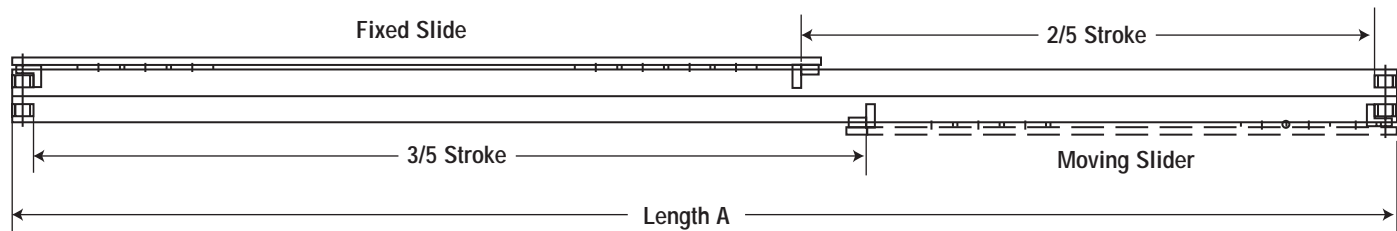

The data and specifications in this publication have been carefully compiled and are believed to be accurate and correct. However, it is the responsibility of the user to determine and ensure the suitability of Pacific Bearing® products for a specific application. Pacific Bearing's only obligation will be to repair or replace without charge, any defective components if returned promptly. No liability is assumed beyond such replacement. *Consult www.pacific-bearing.com for the latest technical updates.



Redi-Rail® Compact Precision Drawer Slides

RDOX57

Linear Motion Systems

RDOX57

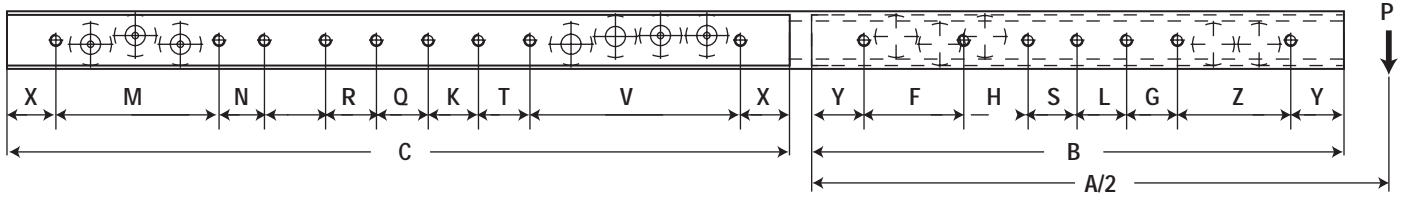

TYPE	STROKE	A	B	C	X	M	P	N	R	Q	K	T	Y	F	H	S	L	Z	CORAD (N)	COAX (N)	(kg.)	
RDOX57-0540	540	530	227	306	61	118	x	118	x				28,5	100	70	x		70	2160	1728	4.8	
RDOX57-0620	620	610	238	375		105	100	100					28	102	80			80	2610	2138	5.4	
RDOX57-0700	700	690	270	423		118	118	118	107	107	107	107	2799	2280	6.0							
RDOX57-0780	780	770	302	471		100	100	100	100	x	x	x	28	123	123	123	x	123	2943	2390	6.7	
RDOX57-0860	860	850	334	519		116	116	116	102				x	28	102	88	88	88	88	2647	2173	7.4
RDOX57-0940	940	930	366	567		120	120	120	136					28,5	103	103	103	103	103	103	103	103
RDOX57-1020	1020	1010	398	615		102	102	102	136					28	114	114	114		114	2297	1912	8.7
RDOX57-1180	1180	1170	462	711		126	126	126	126					136	x	28	102		102	102	102	100
RDOX57-1340	1340	1330	526	807		120	120	120	120	120	120	136		28	120	120	120	110	110	1816	1478	11.3
RDOX57-1500	1500	1490	590	903		116	116	116	116	116	116	136		27,5	107	107	107	107	107	107	1644	1336
RDOX57-1660	1660	1650	654	999		132	132	132	132	132	132	132	136	27,5	120	120	120	120	119	1501	1219	13.8
RDOX57-1820	1820	1810	718	1095		137	125	125	125	125	125	125	125	28	112	110	110	110	110	1382	1120	15.0
RDOX57-1980	1980	1970	782	1191		140	140	140	140	140	140	140	140	28	121	121	121	121	121	1280	1036	16.4

NOTE: S = Left Side
D = Right Side

Roller Positions: Ex. RDOX57 - 0540

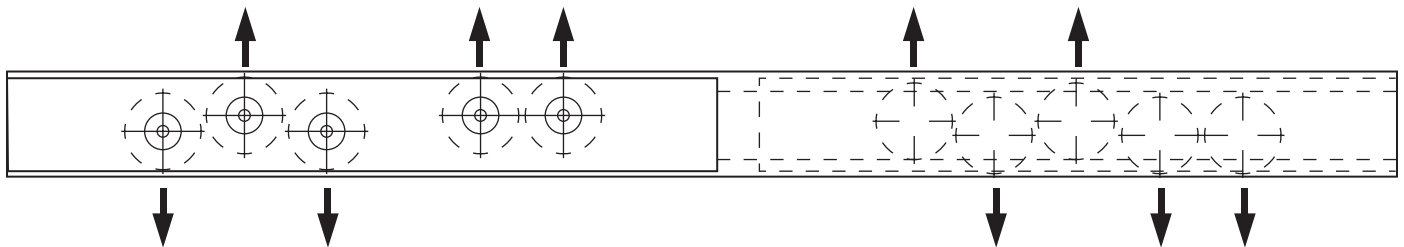

ORDER INFORMATION

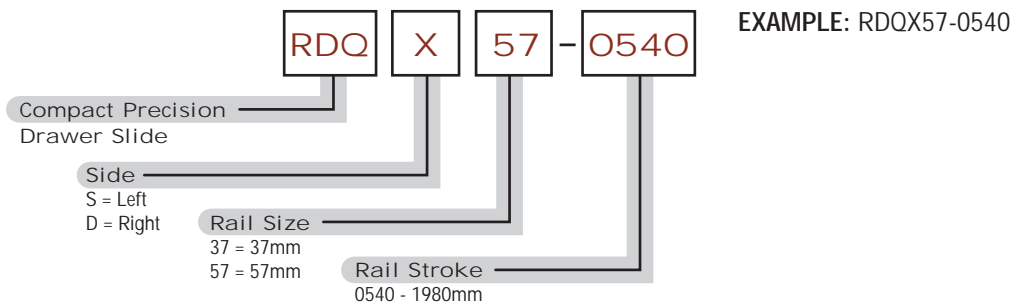

The data and specifications in this publication have been carefully compiled and are believed to be accurate and correct. However, it is the responsibility of the user to determine and ensure the suitability of Pacific Bearing® products for a specific application. Pacific Bearing's only obligation will be to repair or replace without charge, any defective components if returned promptly. No liability is assumed beyond such replacement. *Consult www.pacific-bearing.com for the latest technical updates.



Redi-Rail® Flexible Guide System

43 Rollers & Rails - Radial Loads to 3,600 N

Linear Motion Systems

ROLLERS - 43



FLOATING ROLLER / CONCENTRIC PIVOT - FCP

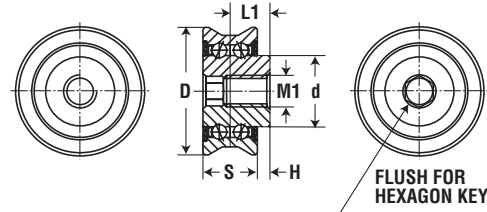

GUIDING ROLLER / ECCENTRIC PIVOT - FEV

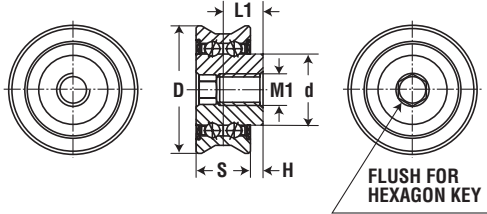

FLOATING ROLLER / ECCENTRIC PIVOT - FEP

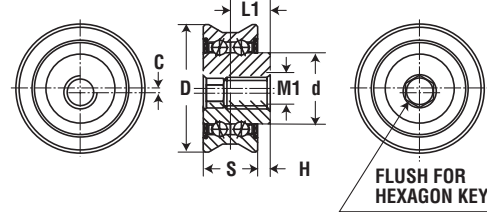

GUIDING ROLLER / CONCENTRIC PIVOT - FCV

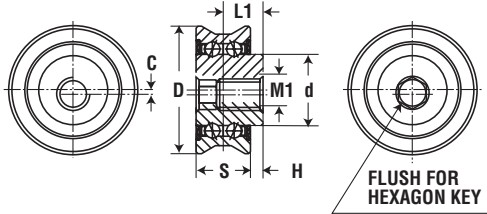

FLOATING ROLLER FEP-FCP LATERAL DISPLACEMENT

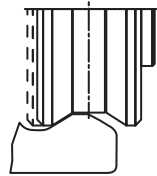

GUIDING ROLLER FCV-FEV

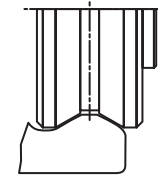

LATERAL DISPLACEMENT	ROLLER TYPE	D	S	H	L1	d	M1	Ch	c	C (N)	CORAD (N)	COAX (N)	WEIGHT (G)
2	FCV43	30.8	14	2	9	15	M8	6	0	9,000	3,600	2,160	50
	FEV43								0.8				
	FCP43	0											
	FEP43	0.8											

RAILS - FR43

The FXR-rails have a unique design as its rail offers three protruding raceways, angled at 90° intervals. Providing an extremely versatile linear system. The stronger FXR-rails have a 160mm hole pitch for easy assembling.

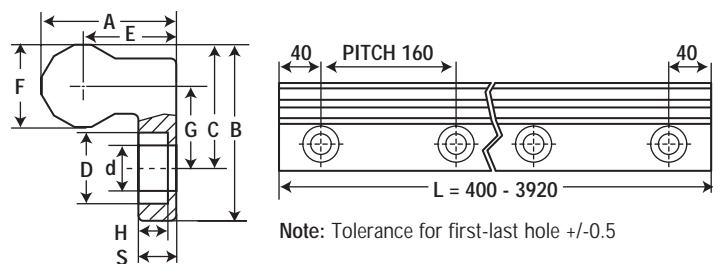

RAIL TYPE	Kg/m	A	B	C	D	d	E	F	G	H	S	L	SCREW TYPE
FR43	2.09	19.36	25	18.3	10.5	6.5	13.2	12.3	12.2	4.4	5.6	400 - 3,920	M6 DIN 6912

ORDER INFORMATION - (ROLLERS)

EXAMPLE: FCP43

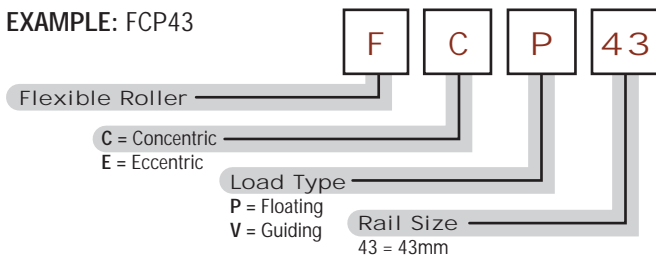

ORDER INFORMATION - (RAILS)

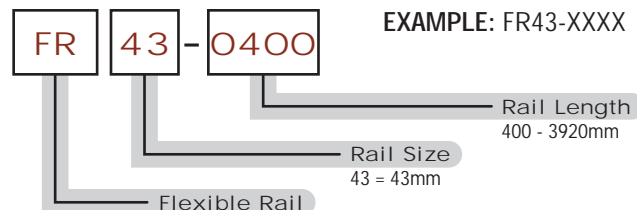

The data and specifications in this publication have been carefully compiled and are believed to be accurate and correct. However, it is the responsibility of the user to determine and ensure the suitability of Pacific Bearing® products for a specific application. Pacific Bearing's only obligation will be to repair or replace without charge, any defective components if returned promptly. No liability is assumed beyond such replacement. *Consult www.pacific-bearing.com for the latest technical updates.



PRODUCT OVERVIEW



Redi-Rail® V-Guide System components provide an excellent alternative for linear motion applications in harsh environments with medium accuracy requirements, and high speed capabilities.

FEATURES & BENEFITS

Redi-Rail V-Guide systems are an industry standard for linear motion, and offer features that make them an ideal solution for a wide range of motion control applications.

V-Guide System:

- Excellent for harsh environments
- High speed capabilities
- Low noise operation

V-Guide Rail:

- Has shoulder for simple mounting and alignment
- Available in long lengths
- Induction hardened way surface

V-Guide Wheels:

- Permanently lubricated
- Precision dual row bearing construction
- Available in 52100 Bearing Steel or 440 Stainless Steel construction

Wheel Bushings:

- 303 Stainless Steel
- Available for English or metric hardware

APPLICATIONS

- Machine tool doors
- Vending machines
- Woodworking machinery
- Carpet and textile machinery
- Laboratory automation
- Paper converting equipment
- Packaging machinery

TECHNICAL SPECIFICATIONS

Linear Bearing for Axial & Radial Loads

Wheels:

Redi-Rail V-Guide Wheels are precision ground dual row angular contact ball bearings with hardened outer way surfaces that provide low friction guidance for linear motion applications. V-Guide wheels can be used with internal or external 90-degree ways, or used with round shafts.

- Available in four sizes
- 52100 Bearing Steel or 440 Stainless Steel construction
- Permanently grease lubricated
- Available with 304 Stainless Steel shields, or nitrile rubber seals

Rails:

Redi-Rail V-Rails are available in four sizes, which are designed for the corresponding size wheels. The V-Ways are induction hardened and polished, while the track body is left soft for easy drilling of mounting holes.

- Available in 1045 Carbon Steel or 400 Stainless Steel
- Optional black oxide finish
- Choose predrilled rail from stock, or custom cut and drilled to your specification

Bushings:

Bushings allow for the wheels to be mounted with the appropriate fastener for the specific application.

- Fixed bushings are used in the primary radial load direction
- Adjustable bushings allow adjustable fit and preload
- Stainless Steel construction

The data and specifications in this publication have been carefully compiled and are believed to be accurate and correct. However, it is the responsibility of the user to determine and ensure the suitability of Pacific Bearing® products for a specific application. Pacific Bearing's only obligation will be to repair or replace without charge, any defective components if returned promptly. No liability is assumed beyond such replacement. *Consult www.pacific-bearing.com for the latest technical updates.



Redi-Rail® V-Guide System

Radial Loads to 283 lbs. (1,260 N) per Wheel

Linear Motion Systems

V-GUIDE WHEELS

VW1	Shielded Bearing
VWS1	Sealed Bearing
VWSS1	Sealed Stainless Bearing

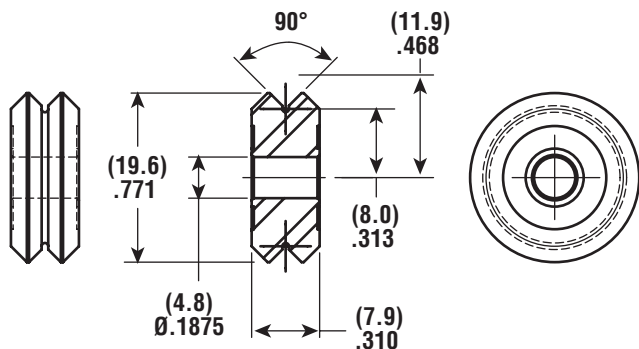

WEIGHT: .42 oz. (12 g)

WHEEL BUSHINGS

VB1	Fixed Bushing
VBA1	Adjustable Bushing

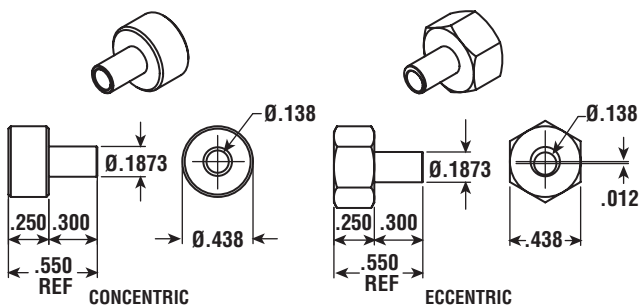

METRIC WHEEL BUSHINGS

MVB1	Metric Fixed Bushing
MVBA1	Metric Adjustable Bushing

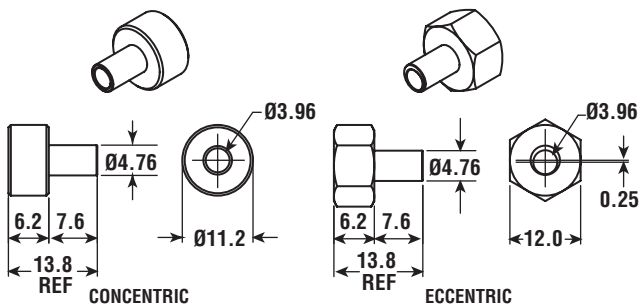

Rated for:

Radial loads to 283 lbs. (1,260 N) per wheel
Axial loads to 67 lbs. (297 N) per wheel

V-GUIDE RAIL

Carbon Steel	
VR1-xxx	undrilled rail max. length 21' (6400 mm)
VRD1-xxx	drilled rail, see table
Stainless Steel	
VRS1-xxx	undrilled rail, max. length 21' (6400 mm)
VRSD1-xxx	drilled rail, see table

NOTE: Non-heat treated rails available in all all sizes, contact factory.

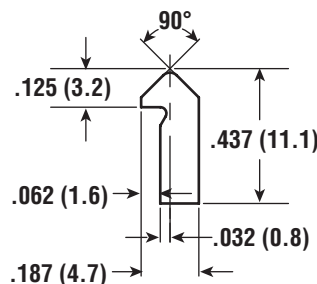

STANDARD DRILLED RAILS

PART NUMBER	LENGTH	NO. OF HOLES
CARBON STEEL		
VRD1-1250	12.5" (317.5 mm)	7
VRD1-2450	24.5" (622.3 mm)	13
VRD1-3650	36.5" (927.1 mm)	19
VRD1-4850	48.5" (1231.9 mm)	25
VRD1-6050	60.5" (1536.7 mm)	31
VRD1-7250	72.5" (1841.5 mm)	37
STAINLESS STEEL		
VRSD1-1250	12.5" (317.5 mm)	7
VRSD1-2450	24.5" (622.3 mm)	13
VRSD1-3650	36.5" (927.1 mm)	19
VRSD1-4850	48.5" (1231.9 mm)	25
VRSD1-6050	60.5" (1536.7 mm)	31
VRSD1-7250	72.5" (1841.5 mm)	37

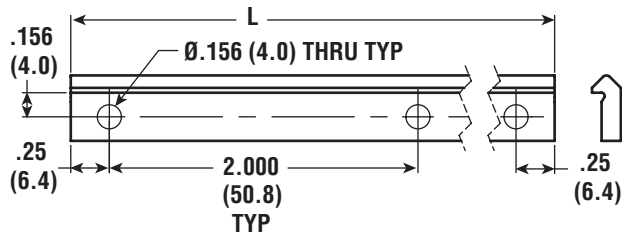

The data and specifications in this publication have been carefully compiled and are believed to be accurate and correct. However, it is the responsibility of the user to determine and ensure the suitability of Pacific Bearing® products for a specific application. Pacific Bearing's only obligation will be to repair or replace without charge, any defective components if returned promptly. No liability is assumed beyond such replacement. *Consult www.pacific-bearing.com for the latest technical updates.



Redi-Rail® V-Guide System

Radial Loads to 614 lbs. (2,730 N) per Wheel

Linear Motion Systems

V-GUIDE WHEELS

VW2	Shielded Bearing
VWS2	Sealed Bearing
VWSS2	Sealed Stainless Bearing

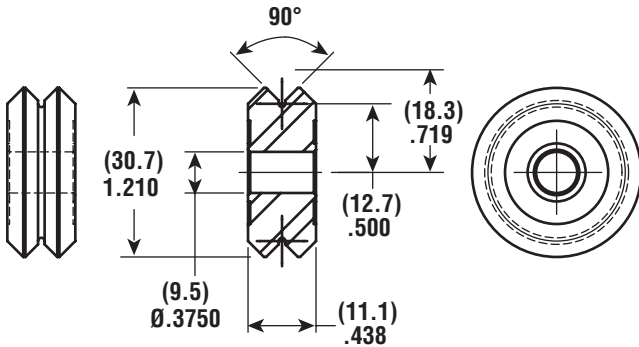

WEIGHT: 1.41 oz. (40 g)

WHEEL BUSHINGS

VB2	Fixed Bushing
VBA2	Adjustable Bushing

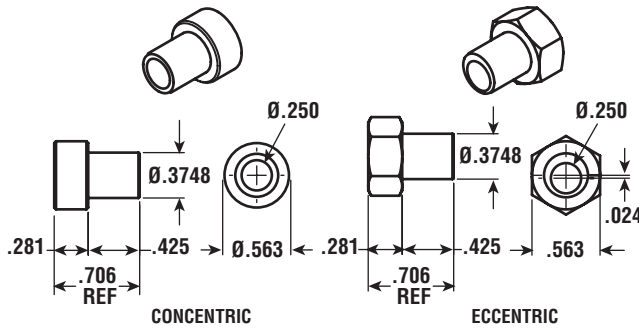

METRIC WHEEL BUSHINGS

MVB2	Metric Fixed Bushing
MVBA2	Metric Adjustable Bushing

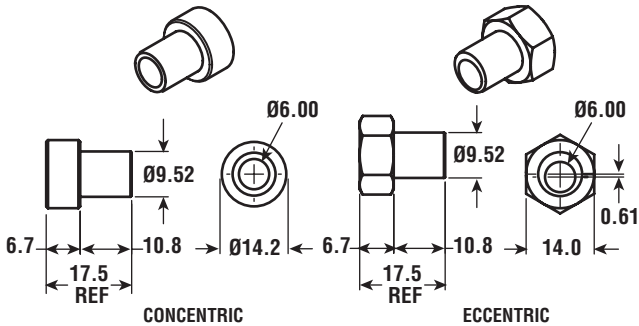

Rated for:
Radial loads to 614 lbs. (2,730 N) per wheel
Axial loads to 142 lbs. (632 N) per wheel

V-GUIDE RAIL

Carbon Steel	
VR2-xxx	undrilled rail max. length 21' (6400 mm)
VRD2-xxx	drilled rail, see table
Stainless Steel	
VRSD2-xxx	undrilled rail, max. length 21' (6400 mm)
VRSD2-xxx	drilled rail, see table

NOTE: Non-heat treated rails available in all all sizes, contact factory.

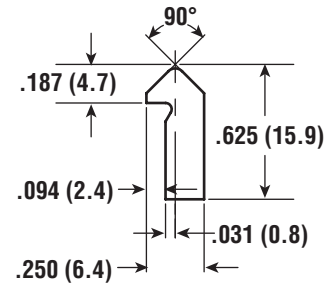

STANDARD DRILLED RAILS

PART NUMBER	LENGTH	# OF HOLES
Carbon Steel		
VRD2-1263	12.63" (320.8 mm)	5
VRD2-2463	24.63" (625.6 mm)	9
VRD2-3663	36.63" (930.4 mm)	13
VRD2-4863	48.63" (1235.2 mm)	17
VRD2-6063	60.63" (1540 mm)	21
VRD2-7263	72.63" (1844.8 mm)	25
Stainless Steel		
VRSD2-1263	12.63" (320.8 mm)	5
VRSD2-2463	24.63" (625.6 mm)	9
VRSD2-3663	36.63" (930.4 mm)	13
VRSD2-4863	48.63" (1235.2 mm)	17
VRSD2-6063	60.63" (1540 mm)	21
VRSD2-7263	72.63" (1844.8 mm)	25

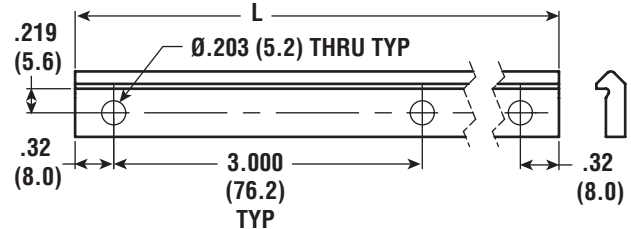

The data and specifications in this publication have been carefully compiled and are believed to be accurate and correct. However, it is the responsibility of the user to determine and ensure the suitability of Pacific Bearing® products for a specific application. Pacific Bearing's only obligation will be to repair or replace without charge, any defective components if returned promptly. No liability is assumed beyond such replacement. *Consult www.pacific-bearing.com for the latest technical updates.



Redi-Rail® V-Guide System

Radial Loads to 1,386 lbs. (6,166 N) per Wheel

Linear Motion Systems

V-GUIDE WHEELS

VW3	Shielded Bearing
VWS3	Sealed Bearing
VWSS3	Sealed Stainless Bearing

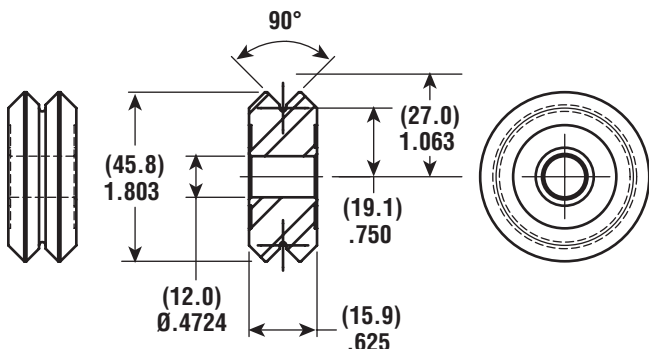

WEIGHT: 4.79 oz. (136 g)

WHEEL BUSHINGS

VB3	Fixed Bushing
VBA3	Adjustable Bushing

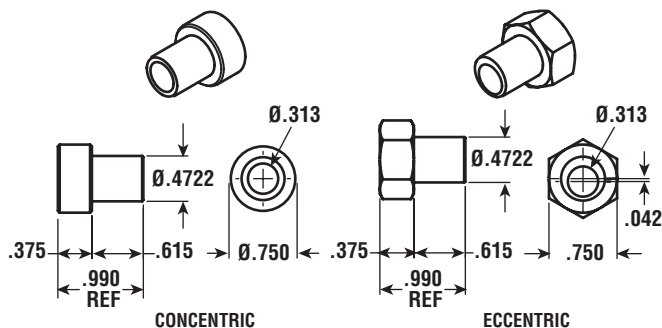

METRIC WHEEL BUSHINGS

MVB3	Metric Fixed Bushing
MVBA3	Metric Adjustable Bushing

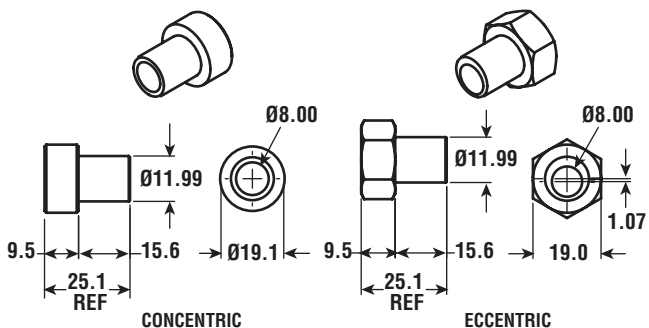

Rated for:

Radial loads to 1,386 lbs. (6,166 N) per wheel
Axial loads to 326 lbs. (1,448 N) per wheel

V-GUIDE RAIL

Carbon Steel	
VR3-xxx	undrilled rail max. length 21' (6400 mm)
VRD3-xxx	drilled rail, see table
Stainless Steel	
VRS3-xxx	undrilled rail, max. length 21' (6400 mm)
VRSD3-xxx	drilled rail, see table

NOTE: Non-heat treated rails available in all all sizes, contact factory.

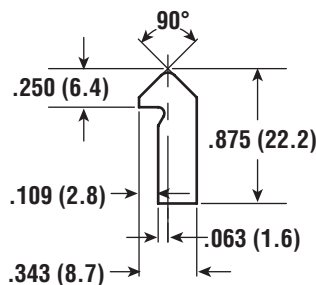

STANDARD DRILLED RAILS

PART NUMBER	LENGTH	# OF HOLES
CARBON STEEL		
VRD3-1275	12.75" (323.9 mm)	5
VRD3-2475	24.75" (628.7 mm)	9
VRD3-3675	36.75" (933.5 mm)	13
VRD3-4875	48.75" (1238.3 mm)	17
VRD3-6075	60.75" (1543.1 mm)	21
VRD3-7275	72.75" (1847.9 mm)	25
STAINLESS STEEL		
VRSD3-1275	12.75" (323.9 mm)	5
VRSD3-2475	24.75" (628.7 mm)	9
VRSD3-3675	36.75" (933.5 mm)	13
VRSD3-4875	48.75" (1238.3 mm)	17
VRSD3-6075	60.75" (1543.1 mm)	21
VRSD3-7275	72.75" (1847.9 mm)	25

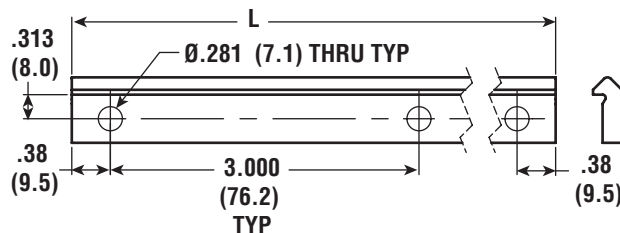

The data and specifications in this publication have been carefully compiled and are believed to be accurate and correct. However, it is the responsibility of the user to determine and ensure the suitability of Pacific Bearing® products for a specific application. Pacific Bearing's only obligation will be to repair or replace without charge, any defective components if returned promptly. No liability is assumed beyond such replacement. *Consult www.pacific-bearing.com for the latest technical updates.

45 mm (1-3/4")



Redi-Rail® V-Guide System

Radial Loads to 2,246 lbs. (9,991 N) per Wheel

Linear Motion Systems

V-GUIDE WHEELS

VW4	Shielded Bearing
VWS4	Sealed Bearing
VWSS4	Sealed Stainless Bearing

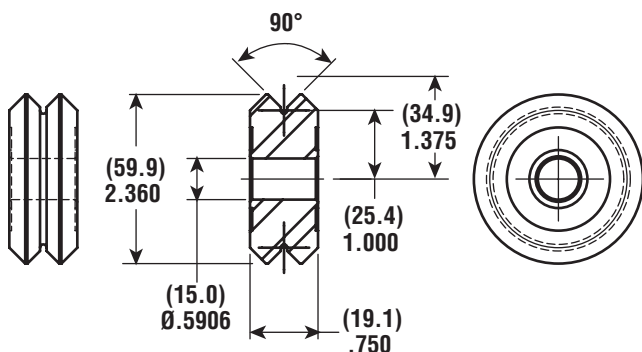

WEIGHT: 10 oz. (285 g)

WHEEL BUSHINGS

VB4	Fixed Bushing
VBA4	Adjustable Bushing

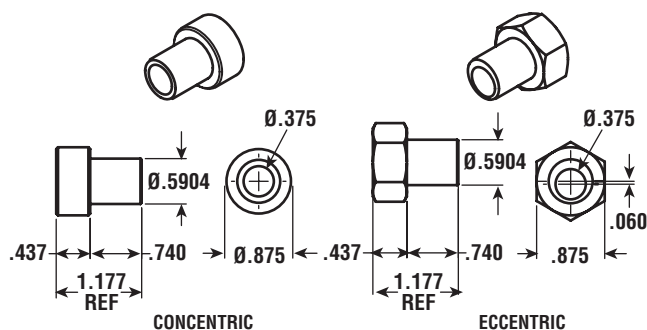

METRIC WHEEL BUSHINGS

MVB4	Metric Fixed Bushing
MVBA4	Metric Adjustable Bushing

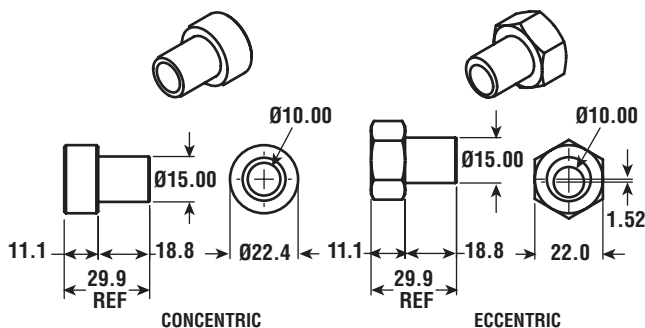

Rated for:

Radial loads to 2,246 lbs. (9,991 N) per wheel
Axial loads to 520 lbs. (2,313 N) per wheel

V-GUIDE RAIL

Carbon Steel	
VR4-xxx	undrilled rail max. length 21' (6400 mm)
VRD4-xxx	drilled rail, see table
Stainless Steel	
VRSD4-xxx	undrilled rail, max. length 21' (6400 mm)
VRSD4-xxx	drilled rail, see table

NOTE: Non-heat treated rails available in all all sizes, contact factory.

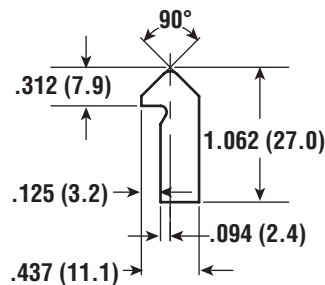

STANDARD DRILLED RAILS

PART NUMBER	LENGTH	# OF HOLES
CARBON STEEL		
VRD4-1300	13.00" (330.2 mm)	4
VRD4-2500	25.00" (635 mm)	7
VRD4-3700	37.00" (939.8 mm)	10
VRD4-4900	49.00" (1244.6 mm)	13
VRD4-6100	61.00" (1549.4 mm)	16
Stainless Steel		
VRSD4-1300	13.00" (330.2 mm)	4
VRSD4-2500	25.00" (635 mm)	7
VRSD4-3700	37.00" (939.8 mm)	10
VRSD4-4900	49.00" (1244.6 mm)	13
VRSD4-6100	61.00" (1549.4 mm)	16

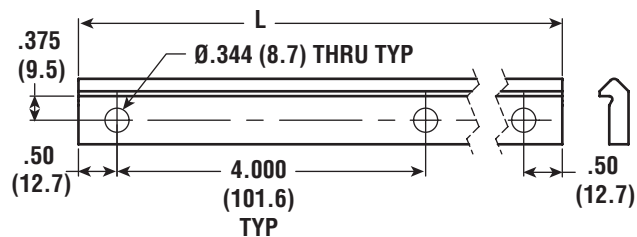

The data and specifications in this publication have been carefully compiled and are believed to be accurate and correct. However, it is the responsibility of the user to determine and ensure the suitability of Pacific Bearing® products for a specific application. Pacific Bearing's only obligation will be to repair or replace without charge, any defective components if returned promptly. No liability is assumed beyond such replacement. *Consult www.pacific-bearing.com for the latest technical updates.



LOAD CALCULATIONS

L = applied load / number of wheel pairs

L_R = wheel radial load

L_0 = wheel load from moment

A = load offset dimension

B = track width dimension

$F_A = .5$ for light duty, well lubricated use

$F_A = 1$ for normal lubricated use

$F_A = 2$ for dry, or harsh environments

LOAD CONDITION A

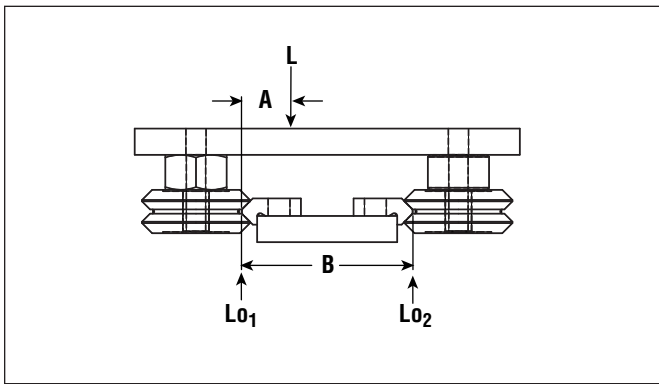

$$L_{O1} = \frac{L \times (B - A)}{B} \times F_A$$

$$L_{O2} = (L \times F_A) - L_{O1}$$

Compare the greater of these loads to the rated moment and radial load capacities.

Example:

Load is 100 lbs on 4 wheel carriage,

$L = 100 / 2$ pair wheels = 50 lbs.

$A = 4"$, $B = 10"$, $F_A = 1$

$$L_{O1} = \frac{50 \times (10 - 4) \times 1}{10} = 30 \text{ lbs.}$$

$$L_{O2} = 50 - 30 = 20 \text{ lbs.}$$

LOAD CONDITION B

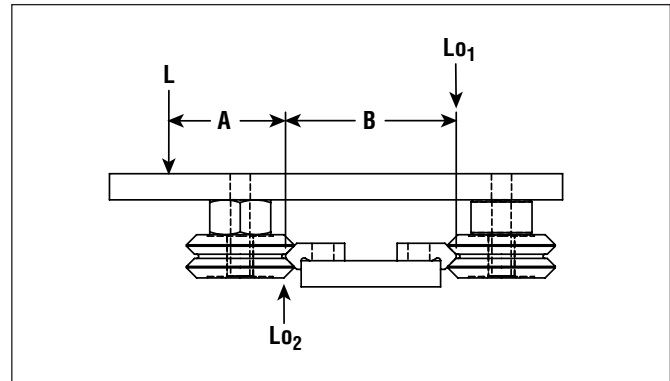

$$L_{O1} = \frac{L \times A}{B} \times F_A$$

$$L_{O2} = (L \times F_A) + L_{O1}$$

Compare the greater of these loads to the rated moment and radial load capacities.

Example:

Load is 100 lbs. on 4 wheel carriage,

$L = 100 / 2$ pair wheels = 50 lbs.

$A = 4"$, $B = 6"$, $F_A = 1$

$$L_{O1} = \frac{50 \times 4 \times 1}{6} = 33 \text{ lbs.}$$

$$L_{O2} = 50 + 33 = 83 \text{ lbs.}$$

LOAD CONDITION C

$$L_{O1} = \frac{L \times A}{B} \times F_A$$

$$L_R = (L \times F_A) + L_{O1}$$

$$L_{O1} = L_{O2}$$

Compare the greater of these loads to the rated moment and radial load capacities.

Example:

Load is 100 lbs. on 4 wheel carriage,

$L = 100 / 2$ pair wheels = 50 lbs.

$A = 4"$, $B = 6"$, $F_A = 1$

$$L_{O1} = \frac{50 \times 4 \times 1}{6} = 33 \text{ lbs.}$$

$$L_R = (50 \times 1) + 33 = 83 \text{ lbs.}$$

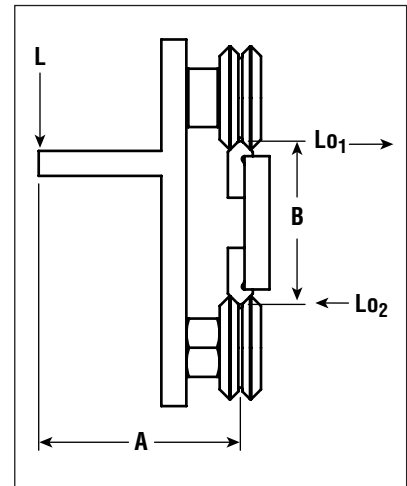

The data and specifications in this publication have been carefully compiled and are believed to be accurate and correct. However, it is the responsibility of the user to determine and ensure the suitability of Pacific Bearing® products for a specific application. Pacific Bearing's only obligation will be to repair or replace without charge, any defective components if returned promptly. No liability is assumed beyond such replacement. *Consult www.pacific-bearing.com for the latest technical updates.



MOUNTING AND ADJUSTMENT

Use the recommended fasteners for the specified track and wheel bushings.

Use the following table, and the center distance formulas in the next column, to configure the appropriate wheel mounting dimensions.

V-RAIL SIZE	IV (in.)	OV (in.)	IV (mm)	OV (mm)
1	0.874	0.934	22.2	23.7
2	1.374	1.436	34.9	36.5
3	2	2.124	50.8	53.9
4	2.624	2.75	66.6	69.9

The fixed bushing should be used to carry the heaviest loading. Preload the adjustable bushing so that the wheel can just be turned by hand. Over-tightening the preload will cause premature wear of the components.

LUBRICATION

The V-Guide wheels are grease lubricated, and will not require any additional lube. The track should be lubricated for optimum performance and service life. Suggested lubricants are Mobil Vactra #2 Way Oil, or Mobil Polyrex EP 2 Extreme Pressure Grease.

SUGGESTED FASTENERS

BUSHINGS			
ENGLISH		METRIC	
VB1	#6	MVB1	M4
VB2	1/4"	MVB2	M6
VB3	5/16"	MVB3	M8
VB4	3/8"	MVB4	M10
V-RAIL			
VR1	#6, M3	VR3	1/4", M6
VR2	#10, M6	VR4	5/16", M8

CENTER DISTANCE FORMULA

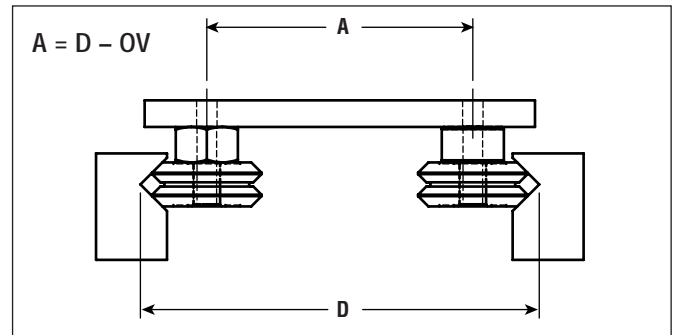
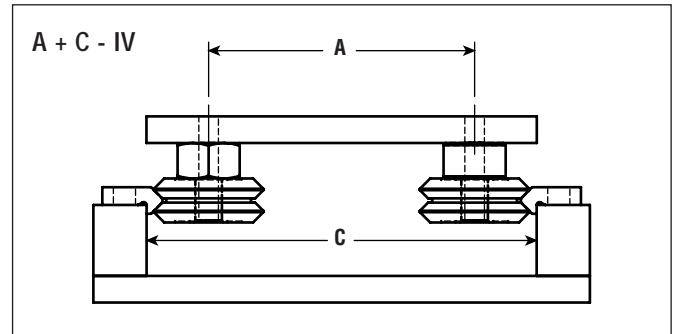
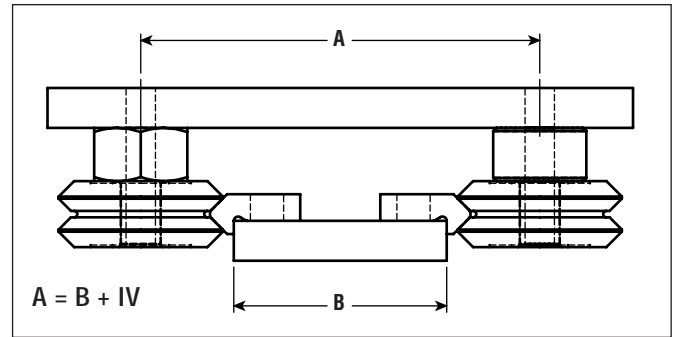

WHEEL / BUSHING ASSEMBLY

Use SAE series N flat washers and lock washers to secure the wheel bushing assemblies.

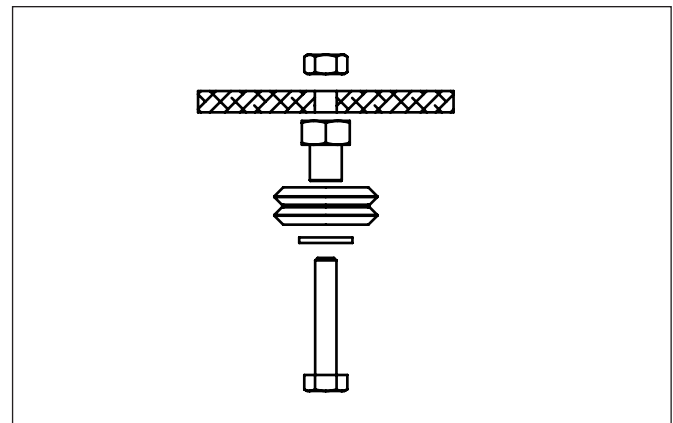

The data and specifications in this publication have been carefully compiled and are believed to be accurate and correct. However, it is the responsibility of the user to determine and ensure the suitability of Pacific Bearing® products for a specific application. Pacific Bearing's only obligation will be to repair or replace without charge, any defective components if returned promptly. No liability is assumed beyond such replacement. *Consult www.pacific-bearing.com for the latest technical updates.



PRODUCT OVERVIEW

The Redi-Rail® Commercial Rail is a simple and cost effective linear motion solution with high load capacity and corrosion resistance. The Commercial Rail is used in various applications such as: Automation, packaging, material handling, environmental, energy, HVAC, medical, office equipment and many others.



FEATURES

- Roll formed rails made of steel/stainless steel sheet for low cost and corrosion resistance application
- Zinc plated rail length up to 6000mm
- Machined slider body made of aluminum alloy and anodized for corrosion resistance
- Steel rollers are made of 52100 chrome steel, hardened and ground, lubricated for life and sealed against contamination
- Stainless steel rollers made of 440C stainless steel for better corrosion resistance, lubricated for life and sealed against contamination
- Rollers made with thread integrated inner ring for ease of assembly and adjustment of pre-load
- Custom polymer wipers can be designed and manufactured to improve the smoothness of motion and service life
- Maximum operating temperature 100°C or 212°F
- Consult with factory for special hole spacing
- Speed up to 1.5 m/s
- Moment loads should be carried by two slides or two parallel rollers

APPLICATIONS

- Automation
- Packaging, material handling, etc
- Environmental, energy, HVAC, etc.
- Medical
- Office equipment

SLIDE ORIENTATION

The 3-roller slide should be installed in the rail so that the load is shared among the two outside rollers. The orientation marks indicate how to align the slider with the load direction

LUBRICATION – RAILS & BEARINGS

The rollers are internally lubricated for life, but the rails must always have a layer of grease. As a guideline, reapply fresh grease every 50,000 cycles.

PRELOAD ADJUSTMENT

- To loosen the center roller, use an Allen wrench to un-tighten the screw while holding the roller still with an open-end wrench
- Turn the center roller to a position to achieve the desired pre-load
- Move the slide along the length of the rail by hand. Adjust it so that it does not feel loose anywhere.
- Tighten the screw while holding the roller flat with an open-end wrench

	CR20/CRSS20	CR30/CRSS30	CR45/CRSS45
Wrench flat sq. (mm)	6	10	14

MATERIAL & FINISH SPECIFICATIONS

	CR SERIES	SS SERIES
Rail	Carbon steel sheet, Zinc plated	Stainless steel 304 sheet
Slide	Aluminum alloy anodized	Aluminum alloy anodized
Rollers	Chrome steel	Stainless steel
Hardware	Steel zinc plated	Stainless steel 18-8

Rail Mount

	CR20/SS20	CR30/SS30	CR45/SS45
Rail mount screw (Button head cap)	M4	M5	M8

Slide Mount

	CR20/CRSS20	CR30/CRSS30	CR45/CRSS45
Slide mount screws (Socket head cap)	M5	M6	M8
Tightening torque (lbs-in)	25	43	103
Tightening torque (N-m)	3	5	12

The data and specifications in this publication have been carefully compiled and are believed to be accurate and correct. However, it is the responsibility of the user to determine and ensure the suitability of Pacific Bearing® products for a specific application. Pacific Bearing's only obligation will be to repair or replace without charge, any defective components if returned promptly. No liability is assumed beyond such replacement. *Consult www.pacific-bearing.com for the latest technical updates.



SLIDE CR20

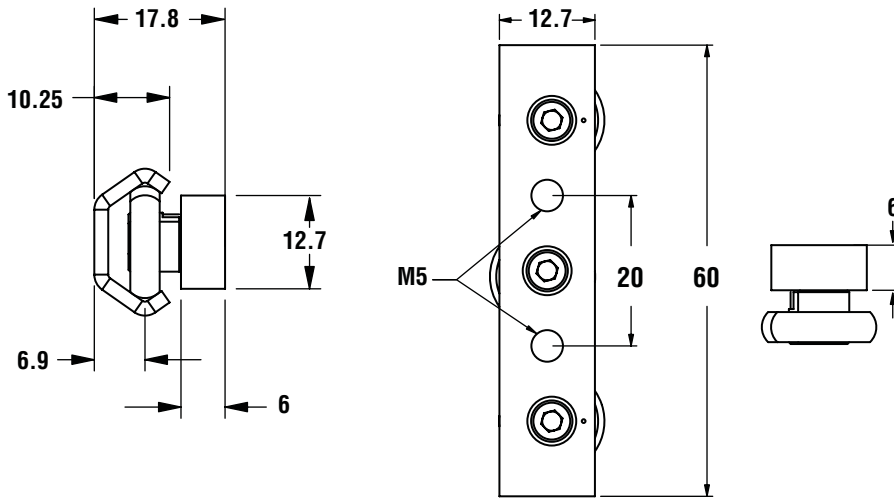

DIMS	LOAD RATINGS		
	STATIC RADIAL C _{0r} (N)	STATIC RADIAL C _{0a} (N)	DYNAMIC RADIAL C _r (N)
CR20	210	160	280
CRSS20			
CRP20	30	20	40

RAIL CR20

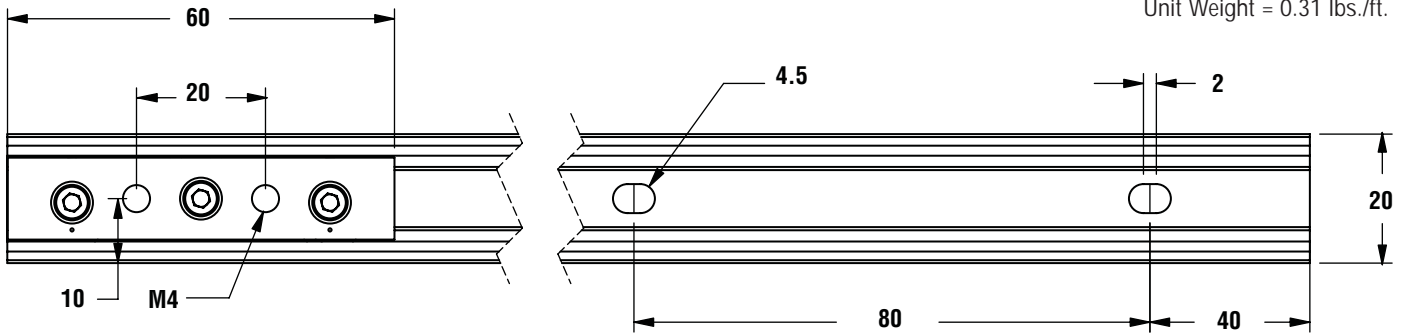

ORDER INFORMATION (SLIDE)

EXAMPLE: CR20MCA

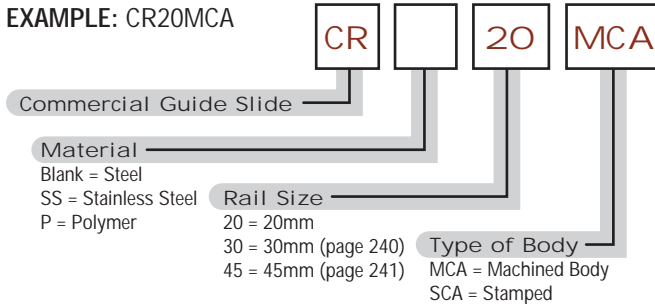

ORDER INFORMATION (RAIL)

EXAMPLE: CR20R-XXXX

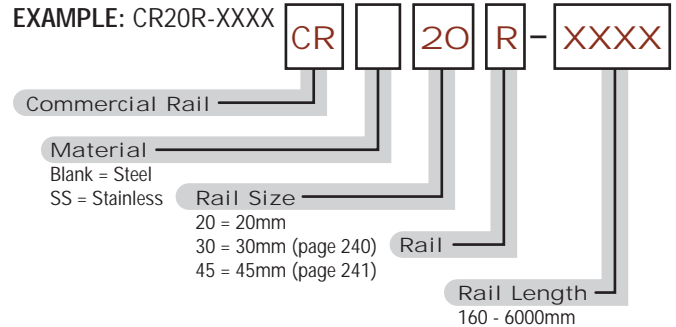

CR20

The data and specifications in this publication have been carefully compiled and are believed to be accurate and correct. However, it is the responsibility of the user to determine and ensure the suitability of Pacific Bearing® products for a specific application. Pacific Bearing's only obligation will be to repair or replace without charge, any defective components if returned promptly. No liability is assumed beyond such replacement. *Consult www.pacific-bearing.com for the latest technical updates.



Redi-Rail® Commercial Rail

CR30 Slide & Rail - Dynamic Radial Cr800 N

Linear Motion Systems

SLIDE CR30

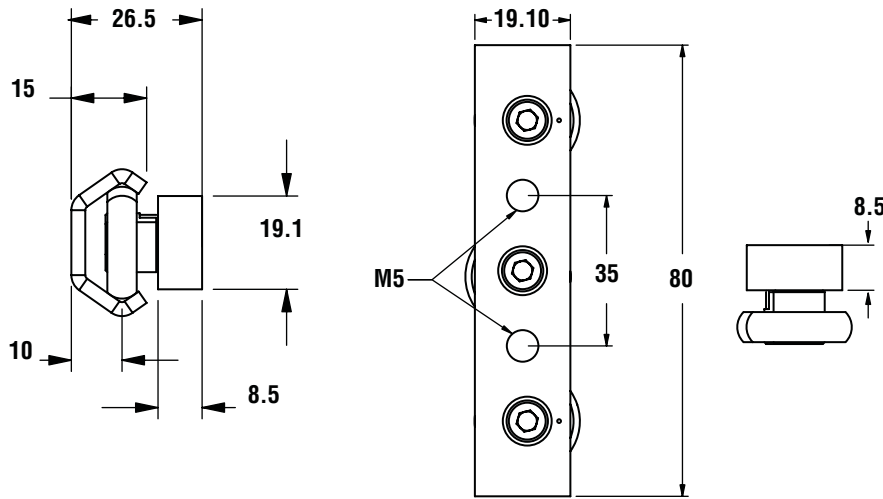

DIMS	LOAD RATINGS		
	STATIC RADIAL Cor. (N)	STATIC RADIAL Coa. (N)	DYNAMIC RADIAL Cr (N)
CR30	610	420	800
CRSS30	610	420	800
CRP30	90	60	120

RAIL CR30

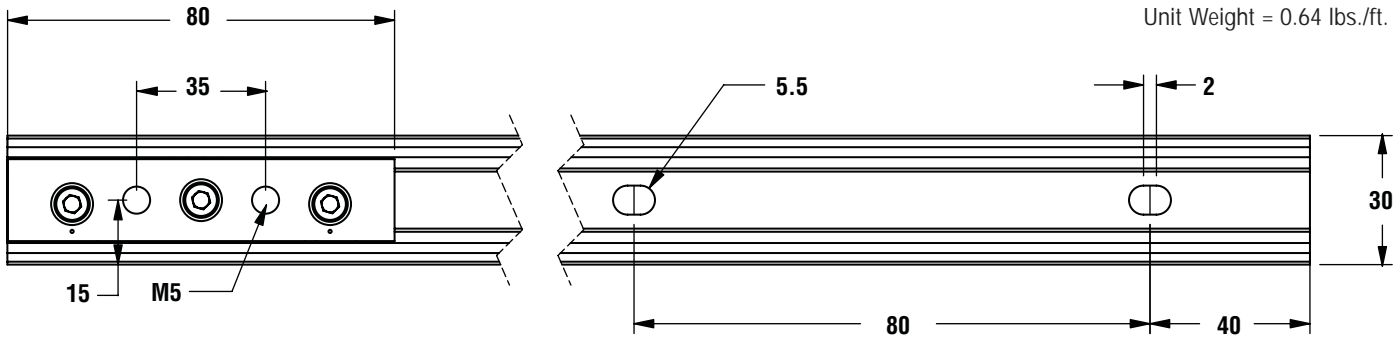

ORDER INFORMATION (SLIDE)

EXAMPLE: CR30MCA

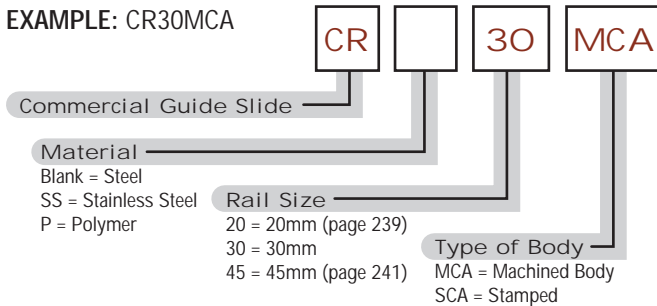

ORDER INFORMATION (RAIL)

EXAMPLE: CR30R-XXXX

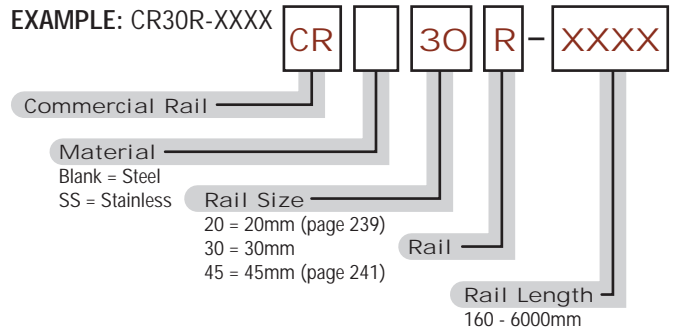

The data and specifications in this publication have been carefully compiled and are believed to be accurate and correct. However, it is the responsibility of the user to determine and ensure the suitability of Pacific Bearing® products for a specific application. Pacific Bearing's only obligation will be to repair or replace without charge, any defective components if returned promptly. No liability is assumed beyond such replacement. *Consult www.pacific-bearing.com for the latest technical updates.



SLIDE CR45

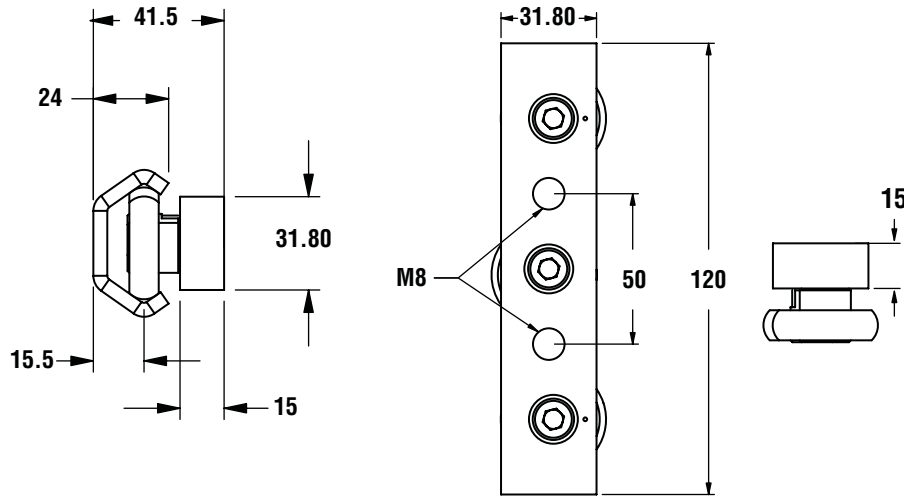

DIMS	LOAD RATINGS		
	STATIC RADIAL C _{0r} (N)	STATIC RADIAL C _{0a} (N)	DYNAMIC RADIAL C _r (N)
CR45	1330	930	1740
CRSS45			
CRP45	190	150	260

RAIL CR45

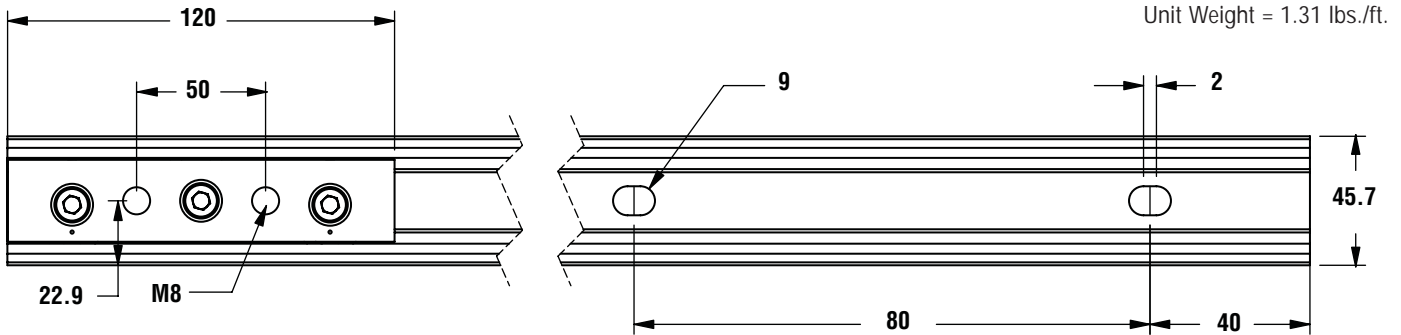

ORDER INFORMATION (SLIDE)

EXAMPLE: CR45MCA

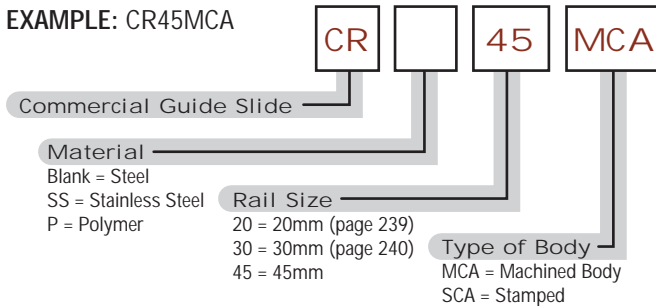

ORDER INFORMATION (RAIL)

EXAMPLE: CR45R-XXXX

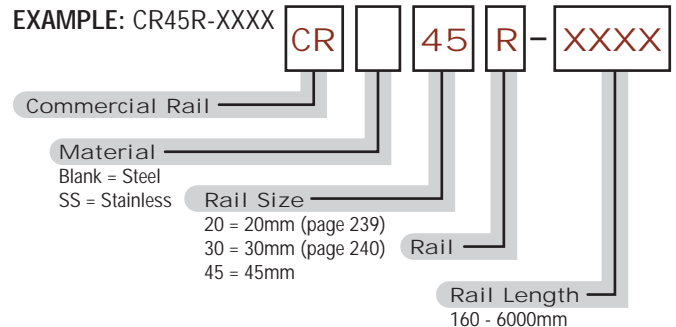

CR45

The data and specifications in this publication have been carefully compiled and are believed to be accurate and correct. However, it is the responsibility of the user to determine and ensure the suitability of Pacific Bearing® products for a specific application. Pacific Bearing's only obligation will be to repair or replace without charge, any defective components if returned promptly. No liability is assumed beyond such replacement. *Consult www.pacific-bearing.com for the latest technical updates.



Redi-Rail® Hardened Crown Rollers

Linear Motion Systems



- Low cost linear motion solution
- Precision rolling element bearing riding in a Unistrut™ type rail
- 9/16" Hex head for easier mounting
- Simple solution and setup for point-to-point applications
- Hardened crown provides self-alignment, good strength, and long life
- MAX. bearing load - 300 lbs.
- MAX. bearing speed - 150 ft./ min. (30 in./sec.)
- Rails available in lengths up to 10'

RAILS AVAILABLE WITH TWO FINISHES:

- Bare steel
- Powder coated

ACCESSORIES AVAILABLE:

- Angle brackets (for welding to mounting rail)
- End stops

™ Unistrut is a trademark of Unistrut, Inc.

ORDERING INFORMATION

PART NO.	DESCRIPTION
PAC3016	Hardened Crown Roller Bearing
PAC3016M	Hardened Crown Roller Bearing with metric thread
PAC2245	Rail System - unpainted (specify length - priced per foot)
PAC2247	Rail System - black powder coat finish (specify length- price per foot)
PAC2244	Angle Brackets - 1" Steel
PAC2246	End Stops for Rail System (bolt included)

INCH

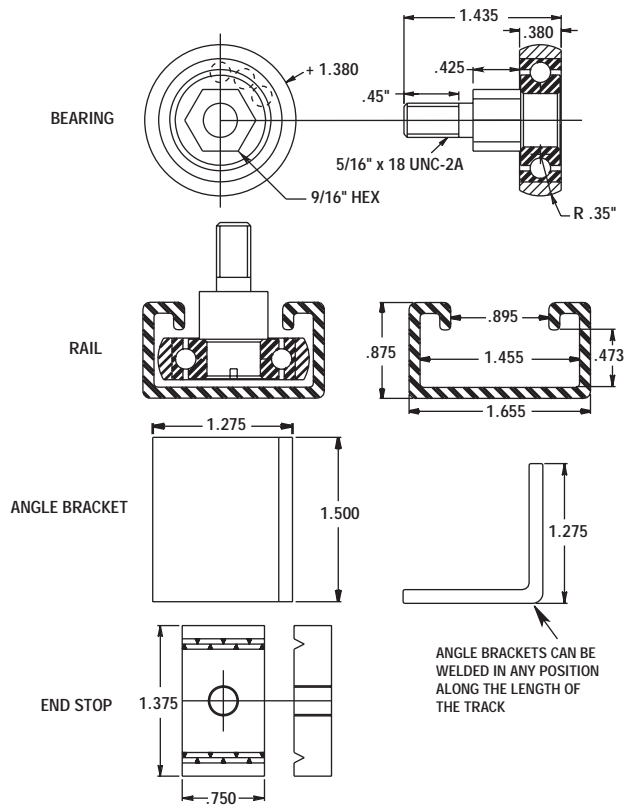

METRIC

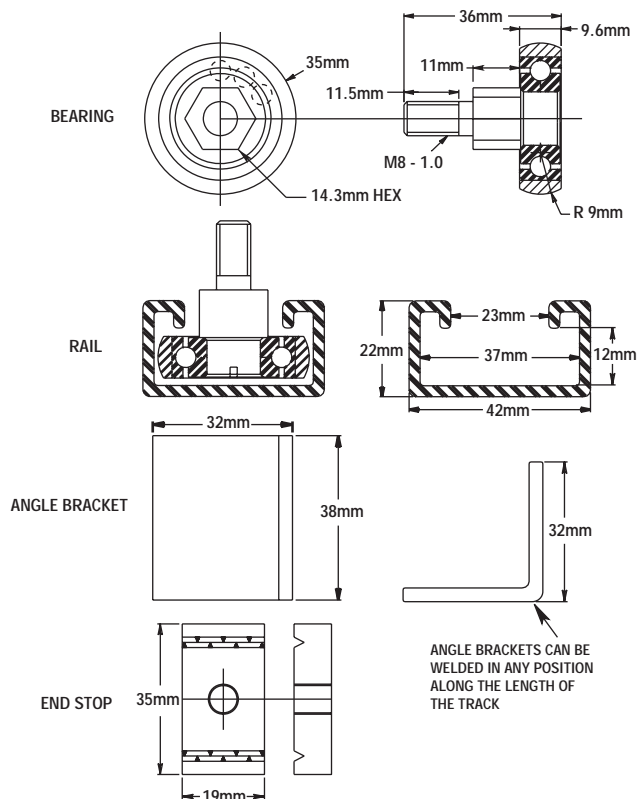

NOTE: All metric dimensions are conversions from inch dimensions all parts are manufactured to inch standards.

The data and specifications in this publication have been carefully compiled and are believed to be accurate and correct. However, it is the responsibility of the user to determine and ensure the suitability of Pacific Bearing® products for a specific application. Pacific Bearing's only obligation will be to repair or replace without charge, any defective components if returned promptly. No liability is assumed beyond such replacement. *Consult www.pacific-bearing.com for the latest technical updates.



The Hevi-Rail® high load capacity linear bearing guide systems from Pacific Bearing provide high axial and radial load capacity for material handling, packaging, automotive, aerospace, steel, paper processing and many more industries and applications with medium to low precision requirements.

FEATURES & BENEFITS

The economical Hevi-Rail® guide systems offer a lifetime of durability under continuous use. The easily interchangeable bearing components provide even dispersion of forces in the profile rails for longer system life and stability.

Linear Bearings:

- Outer ring made of case-hardened steel
- Handles very high axial and radial loads
- Easily interchangeable components for less down-time

Profile Rails:

- Standard length up to 6 meters
- Available sand blasted and lightly oiled
- U-channel and I-channel available

Flange Plates:

- Simple mounting for bearings
- Can be ordered pre-welded to bearing

Ordering example: HVB-054/HVPO-1

Clamp Flanges:

- Adjustable
- Eliminates need for welding and straightening
- Easily adjustable parallelism

APPLICATIONS

Some application examples:

- Telescoping applications (ex. overhead extending jib crane)
- Warehouse handling systems / other material handling
- Custom and standard lift units
- Large Shrink-wrap machinery
- Steel and coil handling
- Large variety of material handling

TECHNICAL SPECIFICATIONS

Linear Bearing for Axial & Radial Loads

Prior to welding, disassemble bearing components. To avoid cracks in welded joints, please use welding electrodes and core weld for unalloyed steel.

Materials:

Outer ring - Case-hardened steel UNI 20 MnCr 5 hardened at 60+2 HRC

Inner ring - Hardened steel En 31 - SAE 52100 hardened at 62-2 HRC

Cylindrical rollers - Flat ground heads are hardened steel, En 31 - SAE 52100, hardened at 59-64 HRC

Welding bolts - Low carbon steel

Bolt tolerance = 0.05 mm

Seals:

Bearings with fixed axial bearing (HVB-053 to HVB-063) - radial bearing has steel labyrinth and side guide roller with rubber seals

Bearings with eccentric adjustable axial bearing (HVBEA-454 to HVBEA-463) - Both radial and axial bearings utilize rubber seals (RS type)

Lubrication:

Bearings are supplied lubricated with grease grade 3. Bearings from HVB-055 to HVB-063 can be relubricated with grease zerk. Adjustable bearings are not available with zerk.

Temperature: Resistant from -10°C to 80°C (14°F to 176°F)

Adjusting Axial Bearing (HVBEA-454 to HVBEA-463)

1. Remove front screws. Heat or tap sharply to break Loctite®.
2. Rotate axial bearing shaft
3. Check dimension A (repeat step 2, if needed)
4. Re-install front screws with Loctite®

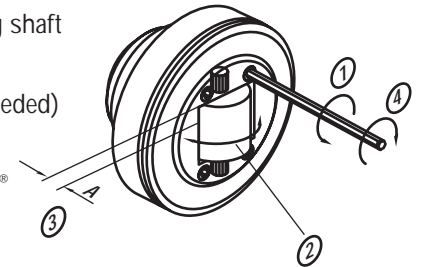

The data and specifications in this publication have been carefully compiled and are believed to be accurate and correct. However, it is the responsibility of the user to determine and ensure the suitability of Pacific Bearing® products for a specific application. Pacific Bearing's only obligation will be to repair or replace without charge, any defective components if returned promptly. No liability is assumed beyond such replacement. *Consult www.pacific-bearing.com for the latest technical updates.



TECHNICAL SPECIFICATIONS (cont.)

PROFILE RAILS

Materials: High quality steel, UNI FE 510.C. Standard length (1024/1524 steel) of 6 m (19.7 ft.). Optional sand blasted and/or lightly oiled.

Rails are not hardened but have a Brinell hardness of 145-185.

The guide ways in the rails should be lightly greased and not painted.

CLAMP FLANGE

Material: Low carbon steel, Adjustable clamp

FLANGE PLATE

Materials: Low carbon steel

Special designs available, call factory.

Optional: Bearings pre-welded to flange plates.

Ordering example: HVB-054/HVPO-1

BEARING LIFE CALCULATION

$$\text{Life (hrs)} = 0.7 \cdot (c/p)^{3.33}$$

c = dynamic load factor (N)

p = actual radial load (N)

LINEAR BEARING SYSTEM SELECTION (when used with Profile Rails HVR-S to HVR-6)

Use the following chart to select the bearings (fixed or adjustable), rails, flange plates and clamp flanges according to your system's maximum static radial and axial loading. A "system" is defined as a bearing in the corresponding rail. For dimensional and detailed specifications for the system selected, simply refer to the corresponding page.

F (KN) MAX STAT RADIAL	F (KN) MAX STAT AXIAL	COMBINED BEARING AXIAL BEARING FIXED	COMBINED BEARING AXIAL BEARING ADJUSTABLE	MPROFILE RAILS	CLAP FLANGE	FLANGE PLATE	PAGE NO.
5.2	1.7	HVB-053	-	HVR-S	-	HVPS-1	244
7.2	2.4	HVB-054	HVBEA-454	HVR-0	HVC-0	HVPO-1	245
8.6	2.8	HVB-055	HVBEA-455	HVR-1, HVRI-07	HVC-1	HVP1-1	246
8.9	3.0	HVB-056	HVBEA-456	HVR-2	HVC-2	HVP2-1	247
8.9	3.0	HVB-057	HVBEA-457	HVRI-08	-	HVP2-1	248
15.6	5.2	HVB-058	HVBEA-458	HVR-3, HVRI-09	HVC-3	HVP3-1	249
15.5	5.1	HVB-059	HVBEA-459	HVRI-10	-	-	250
16.5	5.5	HVB-060	HVBEA-460	HVRI-11	-	-	250
16.5	5.5	HVB-061	HVBEA-461	HVR-4	HVC-4	HVP4-1	251
23.5	7.8	HVB-062	-	HVR-5	-	HVP4-1	252
41.1	13.7	HVB-063	HVBEA-463	HVR-6	-	HVP6-1	253

NOTE: For cantilevered loads, static verification calculations can be found on page 254.

LINEAR BEARING WITH FIXED AXIAL BEARING HVB-053

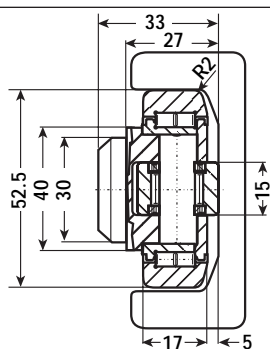

WEIGHT = 0.36 Kg

BEARING RADIAL LOAD

Max. dynamic load = 24 KN

Max. static load = 33 KN

BEARING AXIAL LOAD

Max. dynamic load = 10 KN

Max. static load = 14 KN

NOTE: Above loads achievable when used with a hardened rail 55 RC minimum 2.54mm deep.

PROFILE RAIL U-CHANNEL HVR-S

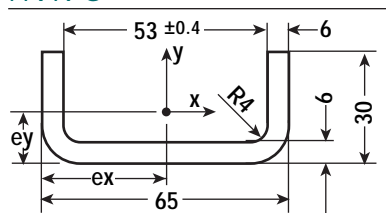

WEIGHT = 5.3 Kg/m

MOMENT OF INERTIA

$$I_x = 5.2 \text{ cm}^4, I_y = 38.8 \text{ cm}^4$$

MOMENT OF RESISTANCE

$$W_x = 2.50 \text{ cm}^3, W_y = 11.90 \text{ cm}^3$$

RADIUS OF INERTIA

$$i_x = 0.80 \text{ cm}, i_y = 2.40 \text{ cm}$$

DIST. TO CENTER OF GRAVITY

$$e_y = 0.94 \text{ cm}, e_x = 32.50 \text{ cm}$$

FLANGE PLATE HVPS-1

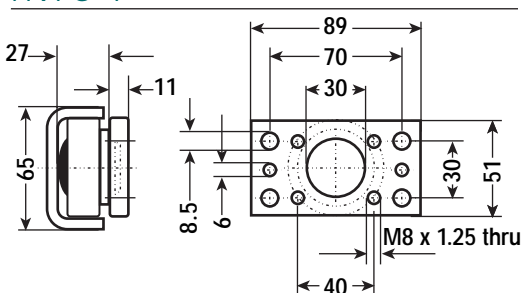

WHEN USED WITH SHOWN PROFILE RAILS, **System Max. Static Radial Load = 5.2 KN / 0.6 US Ton-Force**
System Max. Static Axial Load = 1.7 KN / 0.2 US Ton-Force

*All dimensions in mm, unless otherwise specified.

The data and specifications in this publication have been carefully compiled and are believed to be accurate and correct. However, it is the responsibility of the user to determine and ensure the suitability of Pacific Bearing® products for a specific application. Pacific Bearing's only obligation will be to repair or replace without charge, any defective components if returned promptly. No liability is assumed beyond such replacement. *Consult www.pacific-bearing.com for the latest technical updates.



Hevi-Rail® Linear Bearing Systems

0.8 US Ton-Force

Linear Motion Systems

LINEAR BEARING WITH FIXED AXIAL BEARING HVB-O54

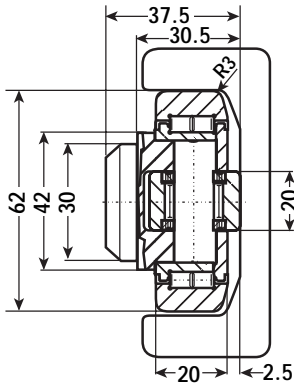

WEIGHT = 0.53 Kg
BEARING RADIAL LOAD
 Max. dynamic load = 39 KN
 Max. static load = 65 KN
BEARING AXIAL LOAD
 Max. dynamic load = 15 KN
 Max. static load = 22 KN
NOTE: Above loads achievable when used with a hardened rail 55 RC minimum 2.54mm deep.

LINEAR BEARING WITH ECCENTRIC ADJUSTABLE AXIAL BEARING HVBEA-454

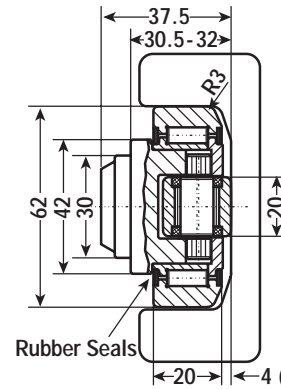

WEIGHT = 0.53 Kg
BEARING RADIAL LOAD
 Max. dynamic load = 39 KN
 Max. static load = 65 KN
BEARING AXIAL LOAD
 Max. dynamic load = 16 KN
 Max. static load = 25 KN
NOTE: Above loads achievable when used with a hardened rail 55 RC minimum 2.54mm deep.

PROFILE RAIL U-CHANNEL HVR-O

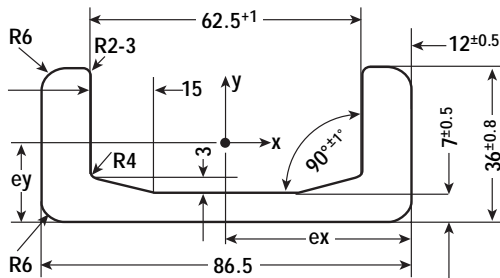

WEIGHT = 10.5 Kg/m
MOMENT OF INERTIA
 $I_x = 15.35 \text{ cm}^4$, $I_y = 137.05 \text{ cm}^4$
DIST. TO CENTER OF GRAVITY
 $e_y = 1.29 \text{ cm}$, $e_x = 4.33 \text{ cm}$
RADIUS OF INERTIA
 $i_x = 1.07 \text{ cm}$, $i_y = 3.20 \text{ cm}$
MOMENT OF RESISTANCE
 $W_{x_{min}} = 6.64 \text{ cm}^3$
 $W_{x_{max}} = 11.93 \text{ cm}^3$
 $W_y = 31.69 \text{ cm}^3$

CLAMP FLANGE HVC-O

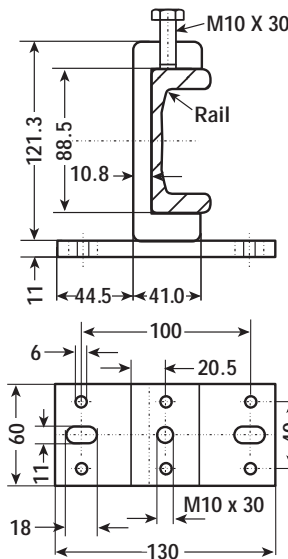

FLANGE PLATE HVPO-1

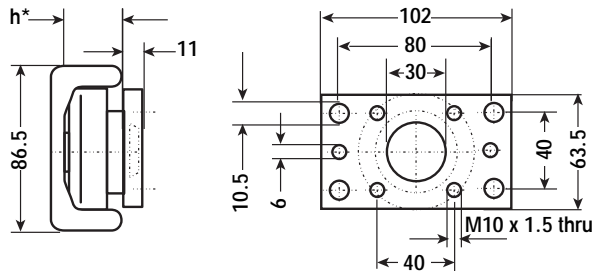

* "h" refers to the depth of the axial bearing, so "h" depends on choice of HVB-054 or HVBEA-454.

WHEN USED WITH SHOWN PROFILE RAILS, **System Max. Static Radial Load = 7.2 KN / 0.8 US Ton-Force**
System Max. Static Axial Load = 2.4 KN / 0.3 US Ton-Force

*All dimensions in mm, unless otherwise specified.

The data and specifications in this publication have been carefully compiled and are believed to be accurate and correct. However, it is the responsibility of the user to determine and ensure the suitability of Pacific Bearing® products for a specific application. Pacific Bearing's only obligation will be to repair or replace without charge, any defective components if returned promptly. No liability is assumed beyond such replacement. *Consult www.pacific-bearing.com for the latest technical updates.



Hevi-Rail® Linear Bearing Systems

0.9 US Ton-Force

Linear Motion Systems

LINEAR BEARING WITH FIXED AXIAL BEARING HVB-O55

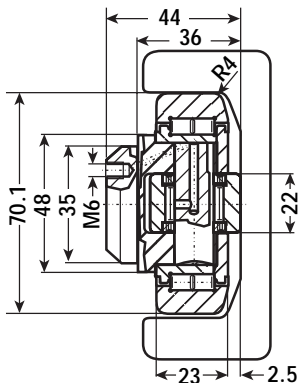

WEIGHT = 0.80 Kg
BEARING AXIAL LOAD
 Max. dynamic load = 18 KN
 Max. static load = 26 KN
NOTE: Above loads achievable when used with a hardened rail 55 RC minimum 2.54mm deep.

LINEAR BEARING WITH ECCENTRIC ADJUSTABLE AXIAL BEARING HVBEA-455

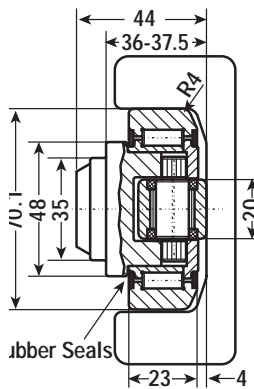

WEIGHT = 0.80 Kg
BEARING RADIAL LOAD
 Max. dynamic load = 56 KN
 Max. static load = 93 KN
BEARING AXIAL LOAD
 Max. dynamic load = 16 KN
 Max. static load = 25 KN
NOTE: Above loads achievable when used with a hardened rail 55 RC minimum 2.54mm deep.

PROFILE RAIL U-CHANNEL HVR-1

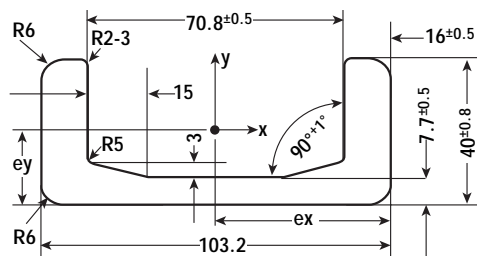

WEIGHT = 14.8 Kg/m
MOMENT OF INERTIA
 $I_x = 27.29 \text{ cm}^4$, $I_y = 273.50 \text{ cm}^4$
DIST. TO CENTER OF GRAVITY
 $e_y = 1.50 \text{ cm}$, $e_x = 5.16 \text{ cm}$
RADIUS OF INERTIA
 $i_x = 1.20 \text{ cm}$, $i_y = 3.81 \text{ cm}$
MOMENT OF RESISTANCE
 $W_{x_{min}} = 10.91 \text{ cm}^3$
 $W_{x_{max}} = 18.20 \text{ cm}^3$
 $W_y = 53.00 \text{ cm}^3$

PROFILE RAIL I-CHANNEL HVRI-O7

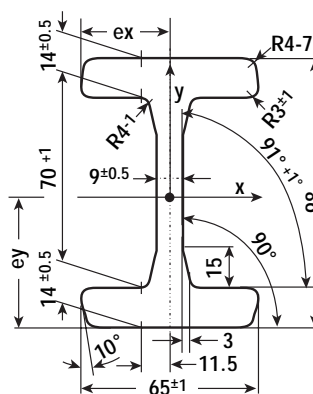

WEIGHT = 19.4 Kg/m
MOMENT OF INERTIA
 $I_x = 344.29 \text{ cm}^4$, $I_y = 57.63 \text{ cm}^4$
DIST. TO CENTER OF GRAVITY
 $e_y = 4.90 \text{ cm}$, $e_x = 3.25 \text{ cm}$
RADIUS OF INERTIA
 $i_x = 3.73 \text{ cm}$, $i_y = 1.52 \text{ cm}$
MOMENT OF RESISTANCE
 $W_x = 70.26 \text{ cm}^3$, $W_y = 17.73 \text{ cm}^3$

CLAMP FLANGE HVC-1

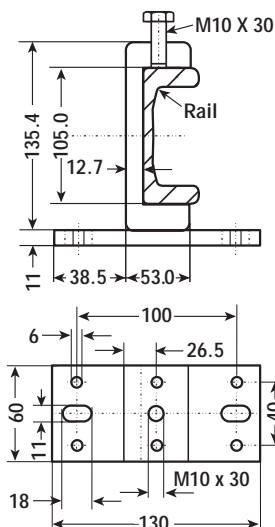

FLANGE PLATE HVP1-1

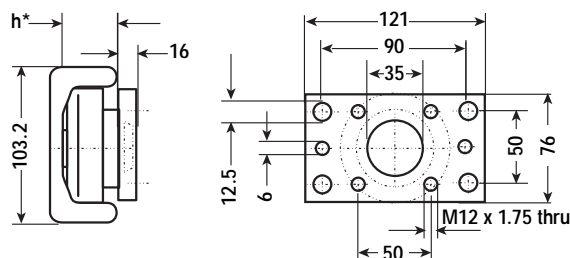

* "h" refers to the depth of the axial bearing, so "h" depends on choice of HVB-055 or HVBEA-455.

WHEN USED WITH SHOWN PROFILE RAILS, **System Max. Static Radial Load = 8.6 KN / 0.9 US Ton-Force**
System Max. Static Axial Load = 2.8 KN / 0.3 US Ton-Force

*All dimensions in mm, unless otherwise specified.

The data and specifications in this publication have been carefully compiled and are believed to be accurate and correct. However, it is the responsibility of the user to determine and ensure the suitability of Pacific Bearing® products for a specific application. Pacific Bearing's only obligation will be to repair or replace without charge, any defective components if returned promptly. No liability is assumed beyond such replacement. *Consult www.pacific-bearing.com for the latest technical updates.



Hevi-Rail® Linear Bearing Systems

1.0 US Ton-Force

Linear Motion Systems

LINEAR BEARING WITH FIXED AXIAL BEARING HVB-056

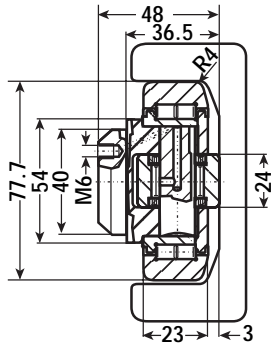

WEIGHT = 1.00 Kg

BEARING RADIAL LOAD

Max. dynamic load = 59 KN
Max. static load = 102 KN

BEARING AXIAL LOAD

Max. dynamic load = 20 KN
Max. static load = 32 KN

NOTE: Above loads achievable when used with a hardened rail 55 RC minimum 2.54mm deep.

LINEAR BEARING WITH ECCENTRIC ADJUSTABLE AXIAL BEARING HVBEA-456

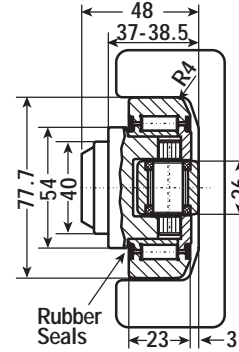

WEIGHT = 1.00 Kg

BEARING RADIAL LOAD

Max. dynamic load = 59 KN
Max. static load = 102 KN

BEARING AXIAL LOAD

Max. dynamic load = 23 KN
Max. static load = 36 KN

NOTE: Above loads achievable when used with a hardened rail 55 RC minimum 2.54mm deep.

PROFILE RAIL U-CHANNEL HVR-2

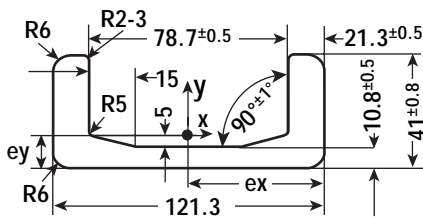

WEIGHT = 20.9 Kg/m

MOMENT OF INERTIA

$I_x = 37.92 \text{ cm}^4$, $I_y = 493.58 \text{ cm}^4$

DIST. TO CENTER OF GRAVITY

$e_y = 1.54 \text{ cm}$, $e_x = 6.07 \text{ cm}$

RADIUS OF INERTIA

$i_x = 1.19 \text{ cm}$, $i_y = 4.30 \text{ cm}$

MOMENT OF RESISTANCE

$W_{x_{min}} = 14.83 \text{ cm}^3$, $W_{x_{max}} = 24.58 \text{ cm}^3$,
 $W_y = 81.38 \text{ cm}^3$

CLAMP FLANGE HVC-2

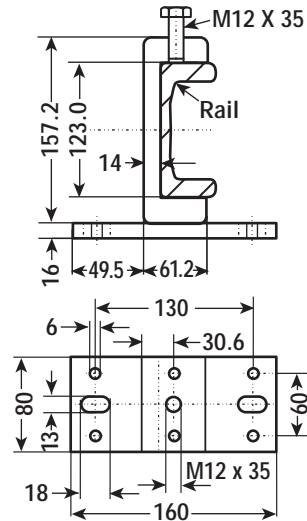

FLANGE PLATE HVP2-1

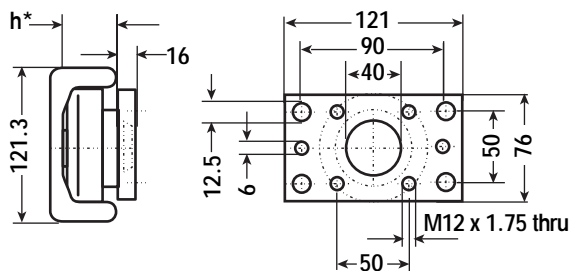

* "h" refers to the depth of the axial bearing,
so "h" depends on choice of HVB-056 or HVBEA-456.

WHEN USED WITH SHOWN PROFILE RAILS, System Max. Static Radial Load = 8.9 KN / 1.0 US Ton-Force
System Max. Static Axial Load = 3.0 KN / 0.3 US Ton-Force

*All dimensions in mm, unless otherwise specified.

The data and specifications in this publication have been carefully compiled and are believed to be accurate and correct. However, it is the responsibility of the user to determine and ensure the suitability of Pacific Bearing® products for a specific application. Pacific Bearing's only obligation will be to repair or replace without charge, any defective components if returned promptly. No liability is assumed beyond such replacement. *Consult www.pacific-bearing.com for the latest technical updates.



Hevi-Rail® Linear Bearing Systems

1.0 US Ton-Force

Linear Motion Systems

LINEAR BEARING WITH FIXED AXIAL BEARING HVB-057

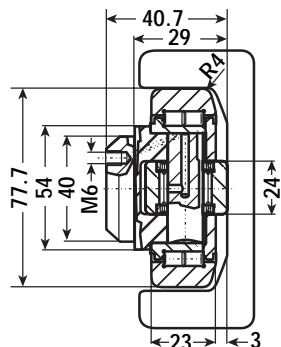

WEIGHT = 0.90 Kg
BEARING RADIAL LOAD
 Max. dynamic load = 59 KN
 Max. static load = 102 KN
BEARING AXIAL LOAD
 Max. dynamic load = 20 KN
 Max. static load = 32 KN
NOTE: Above loads achievable when used with a hardened rail 55 RC minimum 2.54mm deep.

LINEAR BEARING WITH ECCENTRIC ADJUSTABLE AXIAL BEARING HVBEA-457

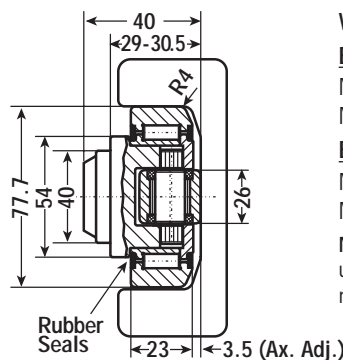

WEIGHT = 0.87 Kg
BEARING RADIAL LOAD
 Max. dynamic load = 59 KN
 Max. static load = 102 KN
BEARING AXIAL LOAD
 Max. dynamic load = 23 KN
 Max. static load = 36 KN
NOTE: Above loads achievable when used with a hardened rail 55 RC minimum 2.54mm deep.

PROFILE RAIL I-CHANNEL HVRI-08

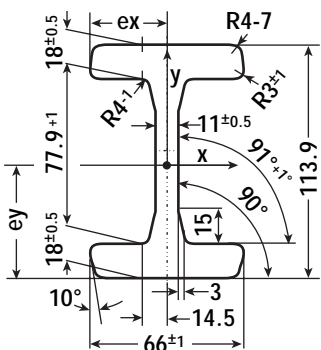

WEIGHT = 25.3 Kg/m
MOMENT OF INERTIA
 $I_x = 597.54 \text{ cm}^4$, $I_y = 76.79 \text{ cm}^4$
DIST. TO CENTER OF GRAVITY
 $e_y = 5.70 \text{ cm}$, $e_x = 3.30 \text{ cm}$
RADIUS OF INERTIA
 $i_x = 4.24 \text{ cm}$, $i_y = 1.54 \text{ cm}$
MOMENT OF RESISTANCE
 $W_x = 104.92 \text{ cm}^3$,
 $W_y = 23.27 \text{ cm}^3$

FLANGE PLATE HVP2-1

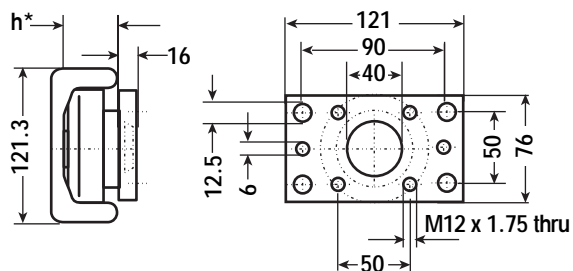

* "h" refers to the depth of the axial bearing,
 so "h" depends on choice of HVB-057 or HVBEA-457.

WHEN USED WITH SHOWN PROFILE RAILS, **System Max. Static Radial Load = 8.9 KN / 1.0 US Ton-Force**
System Max. Static Axial Load = 3.0 KN / 0.3 US Ton-Force

*All dimensions in mm, unless otherwise specified.

The data and specifications in this publication have been carefully compiled and are believed to be accurate and correct. However, it is the responsibility of the user to determine and ensure the suitability of Pacific Bearing® products for a specific application. Pacific Bearing's only obligation will be to repair or replace without charge, any defective components if returned promptly. No liability is assumed beyond such replacement. *Consult www.pacific-bearing.com for the latest technical updates.



Hevi-Rail® Linear Bearing Systems

1.7 US Ton-Force

Linear Motion Systems

LINEAR BEARING WITH FIXED AXIAL BEARING HVB-058

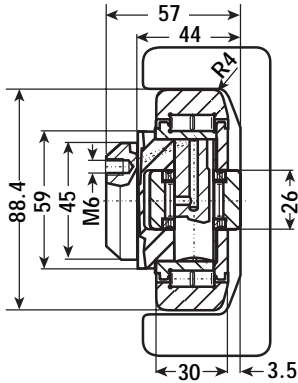

WEIGHT = 1.62 Kg
BEARING RADIAL LOAD
 Max. dynamic load = 85 KN
 Max. static load = 134 KN
BEARING AXIAL LOAD
 Max. dynamic load = 27 KN
 Max. static load = 44 KN

NOTE: Above loads achievable when used with a hardened rail 55 RC minimum 2.54mm deep.

LINEAR BEARING WITH ECCENTRIC ADJUSTABLE AXIAL BEARING HVBEA-458

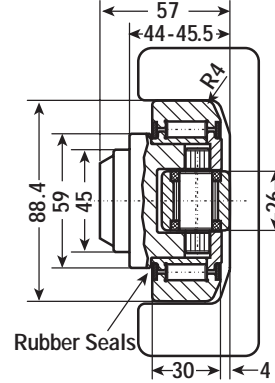

WEIGHT = 1.62 Kg
BEARING RADIAL LOAD
 Max. dynamic load = 85 KN
 Max. static load = 134 KN
BEARING AXIAL LOAD
 Max. dynamic load = 23 KN
 Max. static load = 36 KN

NOTE: Above loads achievable when used with a hardened rail 55 RC minimum 2.54mm deep.

PROFILE RAIL U-CHANNEL HVR-3

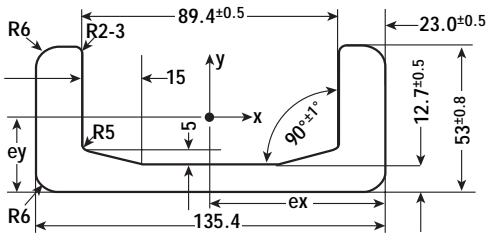

WEIGHT = 28.6 Kg/m
MOMENT OF INERTIA
 $I_x = 89.47 \text{ cm}^4$, $I_y = 865.23 \text{ cm}^4$
DIST. TO CENTER OF GRAVITY
 $e_y = 1.99 \text{ cm}$, $e_x = 6.77 \text{ cm}$

RADIUS OF INERTIA
 $i_x = 1.57 \text{ cm}$, $i_y = 4.87 \text{ cm}$
MOMENT OF RESISTANCE
 $W_{x_{min}} = 27.03 \text{ cm}^3$
 $W_{x_{max}} = 44.96 \text{ cm}^3$
 $W_y = 127.80 \text{ cm}^3$

PROFILE RAIL I-CHANNEL HVRI-09

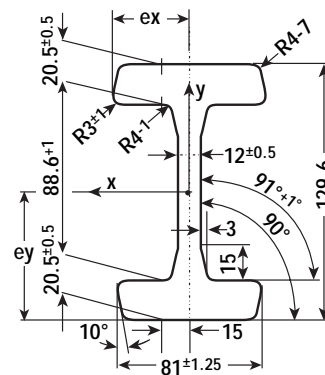

WEIGHT = 34.1 Kg/m
MOMENT OF INERTIA
 $I_x = 1037.22 \text{ cm}^4$, $I_y = 161.89 \text{ cm}^4$
DIST. TO CENTER OF GRAVITY
 $e_y = 6.48 \text{ cm}$, $e_x = 4.05 \text{ cm}$
RADIUS OF INERTIA
 $i_x = 4.89 \text{ cm}$, $i_y = 1.93 \text{ cm}$
MOMENT OF RESISTANCE
 $W_x = 160.07 \text{ cm}^3$,
 $W_y = 39.97 \text{ cm}^3$

CLAMP FLANGE HVC-3

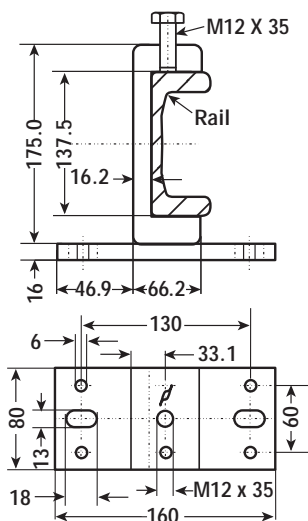

FLANGE PLATE HVP3-1

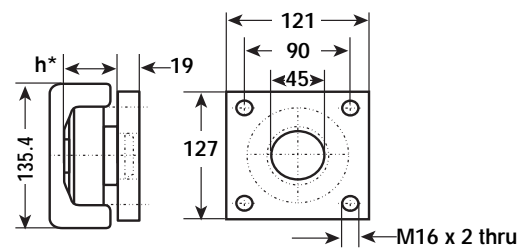

* "h" refers to the depth of the axial bearing, so "h" depends on choice of HVB-058 or HVBEA-458.

WHEN USED WITH SHOWN PROFILE RAILS, **System Max. Static Radial Load = 15.6 KN / 1.7 US Ton-Force**
System Max. Static Axial Load = 5.2 KN / 0.6 US Ton-Force

*All dimensions in mm, unless otherwise specified.

The data and specifications in this publication have been carefully compiled and are believed to be accurate and correct. However, it is the responsibility of the user to determine and ensure the suitability of Pacific Bearing® products for a specific application. Pacific Bearing's only obligation will be to repair or replace without charge, any defective components if returned promptly. No liability is assumed beyond such replacement. *Consult www.pacific-bearing.com for the latest technical updates.



Hevi-Rail® Linear Bearing Systems

1.8 US Ton-Force

Linear Motion Systems

LINEAR BEARING WITH FIXED AXIAL BEARING HVB-O59

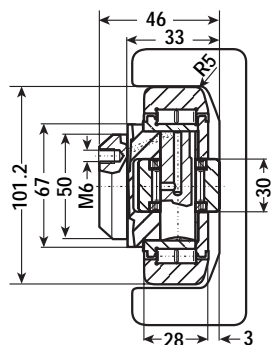

WEIGHT = 1.80 Kg

BEARING RADIAL LOAD

Max. dynamic load = 92 KN

Max. static load = 153 KN

BEARING AXIAL LOAD

Max. dynamic load = 32 KN

Max. static load = 50 KN

NOTE: Above loads achievable when used with a hardened rail 55 RC minimum 2.54mm deep.

PROFILE RAIL I-CHANNEL HVRI-10

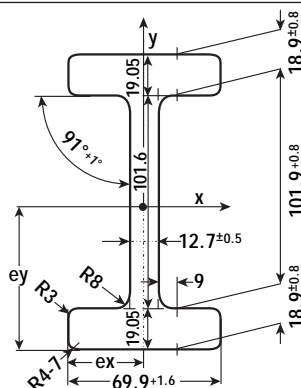

WEIGHT = 30.9 Kg/m

MOMENT OF INERTIA

$I_x = 1078.01 \text{ cm}^4$, $I_y = 104.38 \text{ cm}^4$

DIST. TO CENTER OF GRAVITY

$e_y = 6.99 \text{ cm}$, $e_x = 3.49 \text{ cm}$

MOMENT OF RESISTANCE

$W_x = 154.33 \text{ cm}^3$, $W_y = 29.89 \text{ cm}^3$

LINEAR BEARING WITH ECCENTRIC ADJUSTABLE AXIAL BEARING HVBEA-459

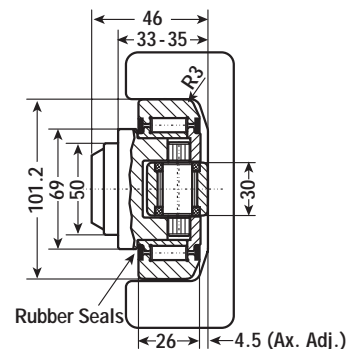

WEIGHT = 1.74 Kg

BEARING RADIAL LOAD

Max. dynamic load = 91 KN

Max. static load = 140 KN

BEARING AXIAL LOAD

Max. dynamic load = 32 KN

Max. static load = 50 KN

NOTE: Above loads achievable when used with a hardened rail 55 RC minimum 2.54mm deep.

WHEN USED WITH SHOWN PROFILE RAILS, System Max. Static Radial Load = 15.5 KN / 1.7 US Ton-Force
System Max. Static Axial Load = 5.1 KN / 0.6 US Ton-Force

*All dimensions in mm, unless otherwise specified.

LINEAR BEARING WITH FIXED AXIAL BEARING HVB-O60

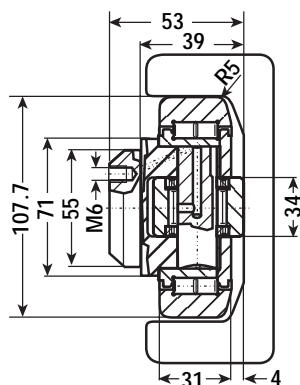

WEIGHT = 2.30 Kg

BEARING RADIAL LOAD

Max. dynamic load = 100 KN

Max. static load = 174 KN

BEARING AXIAL LOAD

Max. dynamic load = 39 KN

Max. static load = 66 KN

NOTE: Above loads achievable when used with a hardened rail 55 RC minimum 2.54mm deep.

PROFILE RAIL I-CHANNEL HVRI-11

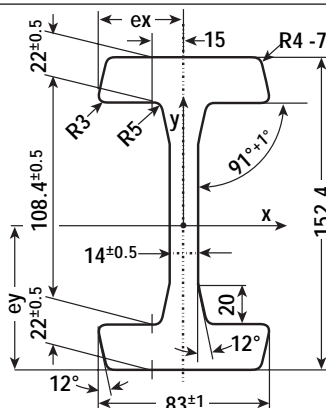

WEIGHT = 40.5 Kg/m

MOMENT OF INERTIA

$I_x = 1670.08 \text{ cm}^4$, $I_y = 184.52 \text{ cm}^4$

DIST. TO CENTER OF GRAVITY

$e_y = 7.62 \text{ cm}$, $e_x = 4.15 \text{ cm}$

RADIUS OF INERTIA

$i_x = 5.69 \text{ cm}$, $i_y = 1.91 \text{ cm}$

MOMENT OF RESISTANCE

$W_x = 219.17 \text{ cm}^3$, $W_y = 44.46 \text{ cm}^3$

LINEAR BEARING WITH ECCENTRIC ADJUSTABLE AXIAL BEARING HVBEA-460

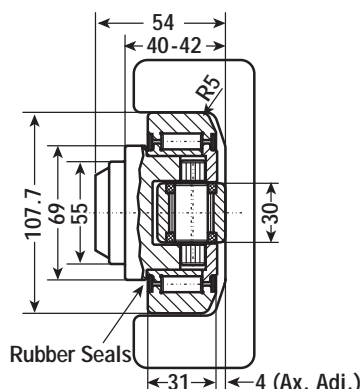

WEIGHT = 2.27 Kg

BEARING RADIAL LOAD

Max. dynamic load = 100 KN

Max. static load = 174 KN

BEARING AXIAL LOAD

Max. dynamic load = 32 KN

Max. static load = 50 KN

NOTE: Above loads achievable when used with a hardened rail 55 RC minimum 2.54mm deep.

WHEN USED WITH SHOWN PROFILE RAILS, System Max. Static Radial Load = 16.5 KN / 1.8 US Ton-Force
System Max. Static Axial Load = 5.5 KN / 0.6 US Ton-Force

*All dimensions in mm, unless otherwise specified.

The data and specifications in this publication have been carefully compiled and are believed to be accurate and correct. However, it is the responsibility of the user to determine and ensure the suitability of Pacific Bearing® products for a specific application. Pacific Bearing's only obligation will be to repair or replace without charge, any defective components if returned promptly. No liability is assumed beyond such replacement. *Consult www.pacific-bearing.com for the latest technical updates.



Hevi-Rail® Linear Bearing Systems

1.8 US Ton-Force

Linear Motion Systems

LINEAR BEARING WITH FIXED AXIAL BEARING HVB-061

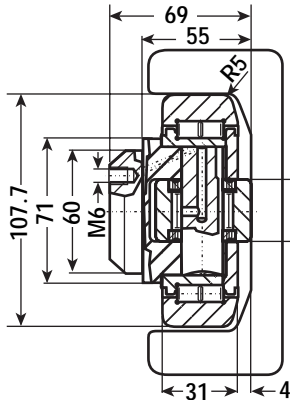

WEIGHT = 2.82 Kg

BEARING RADIAL LOAD

Max. dynamic load = 100 KN
Max. static load = 174 KN

BEARING AXIAL LOAD

Max. dynamic load = 39 KN
Max. static load = 66 KN

NOTE: Above loads achievable when used with a hardened rail 55 RC minimum 2.54mm deep.

LINEAR BEARING WITH ECCENTRIC ADJUSTABLE AXIAL BEARING HVBEA-461

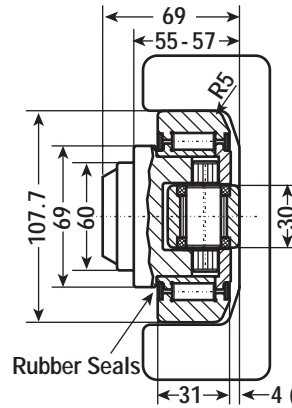

WEIGHT = 2.82 Kg

BEARING RADIAL LOAD

Max. dynamic load = 100 KN
Max. static load = 174 KN

BEARING AXIAL LOAD

Max. dynamic load = 32 KN
Max. static load = 50 KN

NOTE: Above loads achievable when used with a hardened rail 55 RC minimum 2.54mm deep.

PROFILE RAIL U-CHANNEL HVR-4

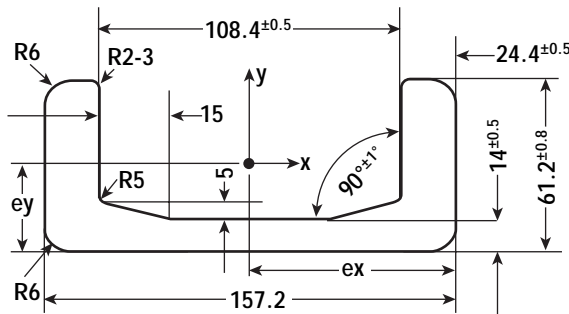

WEIGHT = 35.9 Kg/m

MOMENT OF INERTIA

$I_x = 150.98 \text{ cm}^4$
 $I_y = 1,494.32 \text{ cm}^4$

DIST. TO CENTER OF GRAVITY

$e_y = 2.25 \text{ cm}$, $e_x = 7.86 \text{ cm}$

RADIUS OF INERTIA

$i_x = 1.82 \text{ cm}$, $i_y = 5.72 \text{ cm}$

MOMENT OF RESISTANCE

$W_{x_{min}} = 39.00 \text{ cm}^3$
 $W_{x_{max}} = 67.13 \text{ cm}^3$
 $W_y = 190.12 \text{ cm}^3$

CLAMP FLANGE HVC-4

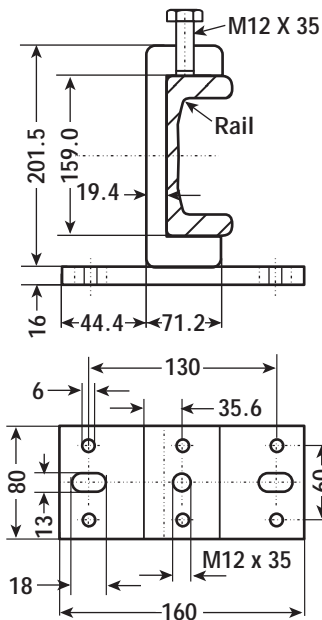

FLANGE PLATE HVP4-1

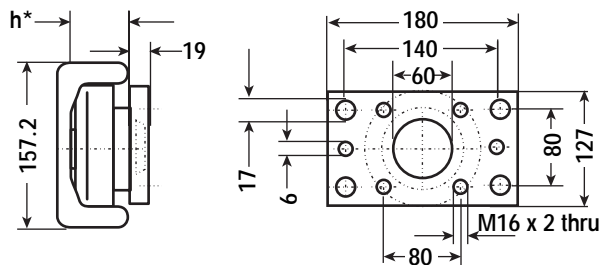

* "h" refers to the depth of the axial bearing, so "h" depends on choice of HVB-061 or HVBEA-461.

WHEN USED WITH SHOWN PROFILE RAILS, System Max. Static Radial Load = 16.5 KN / 1.8 US Ton-Force
System Max. Static Axial Load = 5.5 KN / 0.6 US Ton-Force

*All dimensions in mm, unless otherwise specified.

The data and specifications in this publication have been carefully compiled and are believed to be accurate and correct. However, it is the responsibility of the user to determine and ensure the suitability of Pacific Bearing® products for a specific application. Pacific Bearing's only obligation will be to repair or replace without charge, any defective components if returned promptly. No liability is assumed beyond such replacement. *Consult www.pacific-bearing.com for the latest technical updates.



Hevi-Rail® Linear Bearing Systems

2.6 US Ton-Force

Linear Motion Systems

LINEAR BEARING WITH FIXED AXIAL BEARING HVB-062

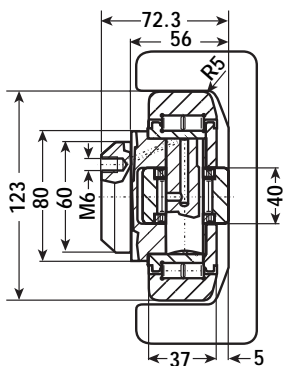

WEIGHT = 4.50 Kg
BEARING RADIAL LOAD
 Max. dynamic load = 135 KN
 Max. static load = 242 KN
BEARING AXIAL LOAD
 Max. dynamic load = 47 KN
 Max. static load = 90 KN
NOTE: Above loads achievable when used with a hardened rail 55 RC minimum 2.54mm deep.

PROFILE RAIL HVR-5

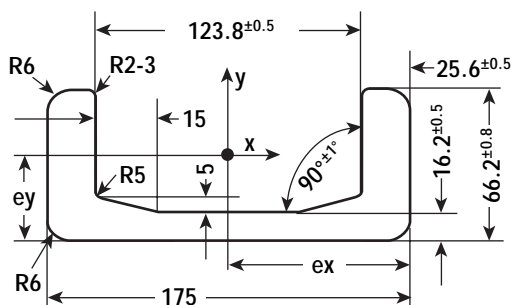

WEIGHT = 42.9 Kg/m
MOMENT OF INERTIA
 $I_x = 205.84 \text{ cm}^4$
 $I_y = 2,185.32 \text{ cm}^4$
DIST. TO CENTER OF GRAVITY
 $e_y = 2.37 \text{ cm}$, $e_x = 8.75 \text{ cm}$
RADIUS OF INERTIA
 $i_x = 1.94 \text{ cm}$, $i_y = 6.32 \text{ cm}$
MOMENT OF RESISTANCE
 $W_{x_{\min}} = 48.42 \text{ cm}^3$
 $W_{x_{\max}} = 86.89 \text{ cm}^3$
 $W_y = 249.75 \text{ cm}^3$

FLANGE PLATE HVP4-1

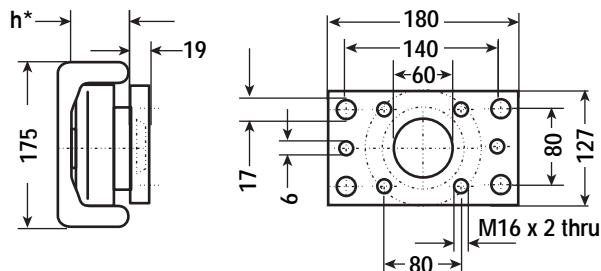

* "h" refers to the depth of the axial bearing, so "h" depends on choice of HVB-062 or HVBEA-462.

2.6 US Ton-Force

WHEN USED WITH SHOWN PROFILE RAILS,

System Max. Static Radial Load = 23.5 KN / 2.6 US Ton-Force
System Max. Static Axial Load = 7.8 KN / 0.9 US Ton-Force

*All dimensions in mm, unless otherwise specified.

The data and specifications in this publication have been carefully compiled and are believed to be accurate and correct. However, it is the responsibility of the user to determine and ensure the suitability of Pacific Bearing® products for a specific application. Pacific Bearing's only obligation will be to repair or replace without charge, any defective components if returned promptly. No liability is assumed beyond such replacement. *Consult www.pacific-bearing.com for the latest technical updates.



Hevi-Rail® Linear Bearing Systems

4.6 US Ton-Force

Linear Motion Systems

LINEAR BEARING WITH FIXED AXIAL BEARING HVB-063

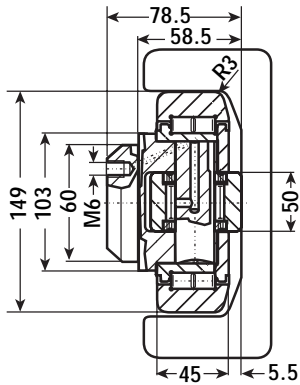

WEIGHT = 6.52 Kg

BEARING RADIAL LOAD

Max. dynamic load = 183 KN
Max. static load = 353 KN

BEARING AXIAL LOAD

Max. dynamic load = 82 KN
Max. static load = 131 KN

NOTE: Above loads achievable when used with a hardened rail 55 RC minimum 2.54mm deep.

LINEAR BEARING WITH ECCENTRIC ADJUSTABLE AXIAL BEARING HVBEA-463

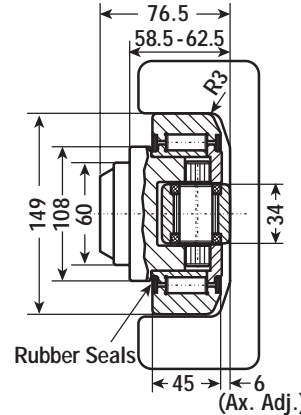

WEIGHT = 6.50 Kg

BEARING RADIAL LOAD

Max. dynamic load = 183 KN
Max. static load = 353 KN

BEARING AXIAL LOAD

Max. dynamic load = 41 KN
Max. static load = 72 KN

NOTE: Above loads achievable when used with a hardened rail 55 RC minimum 2.54mm deep.

PROFILE RAIL HVR-6

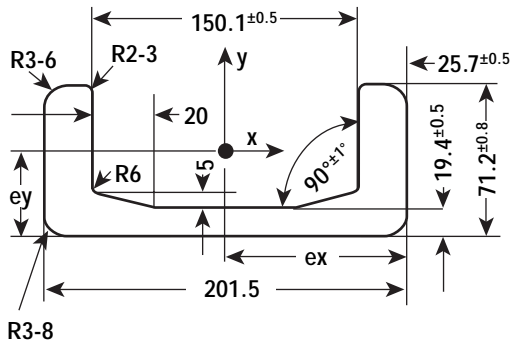

R3-8

WEIGHT = 52.3 Kg/m

MOMENT OF INERTIA

$I_x = 269.52 \text{ cm}^4$,
 $I_y = 3,423.08 \text{ cm}^4$

DIST. TO CENTER OF GRAVITY

$e_y = 2.40 \text{ cm}$, $e_x = 10.08 \text{ cm}$

RADIUS OF INERTIA

$i_x = 2.01 \text{ cm}$, $i_y = 7.17 \text{ cm}$

MOMENT OF RESISTANCE

$W_{x_{\min}} = 57.15 \text{ cm}^3$
 $W_{x_{\max}} = 112.11 \text{ cm}^3$
 $W_y = 339.76 \text{ cm}^3$

FLANGE PLATE HVP6-1

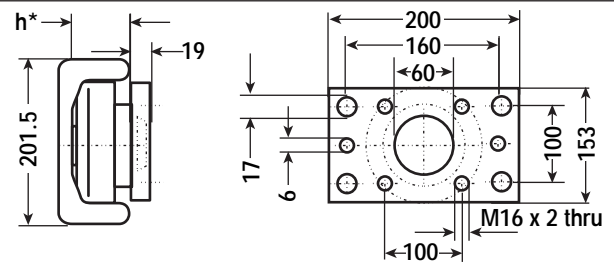

* "h" refers to the depth of the axial bearing, so "h" depends on choice of HVB-063 or HVBEA-463.

WHEN USED WITH SHOWN PROFILE RAILS, **System Max. Static Radial Load = 41.1 KN / 4.6 US Ton-Force**
System Max. Static Axial Load = 13.7 KN / 1.5 US Ton-Force

*All dimensions in mm, unless otherwise specified.

The data and specifications in this publication have been carefully compiled and are believed to be accurate and correct. However, it is the responsibility of the user to determine and ensure the suitability of Pacific Bearing® products for a specific application. Pacific Bearing's only obligation will be to repair or replace without charge, any defective components if returned promptly. No liability is assumed beyond such replacement. *Consult www.pacific-bearing.com for the latest technical updates.



CALCULATION OF FMAX FOR CANTILEVERED LOADS

Q = Load capacity (N)

L = Load distance to suspension point (mm)

P = Suspension point

A = Bearing distance (mm) recommended 500–1000 mm

$$\text{Formula: } F_{\text{max stat radial}} [N] = \frac{Q \cdot L}{2 \cdot A}$$

To avoid wearout in the rail, which is not hardened, the pressure between bearing and rail should be max.

$P_{\text{zul}} = 860 \text{ N/mm}^2$ for Profile Rails HVB-0 to HVB-6.

$P_{\text{zul}} = 750 \text{ N/mm}^2$ for all profile rails. Indicated here are $F_{\text{max stat radial}} + \text{axial}$ for each bearing.

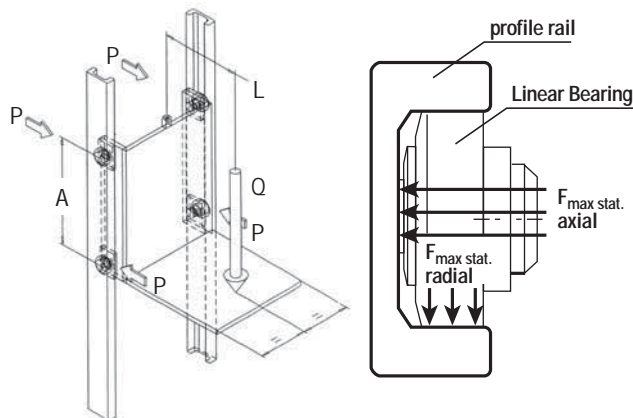

POSSIBLE MOUNTING CONFIGURATIONS

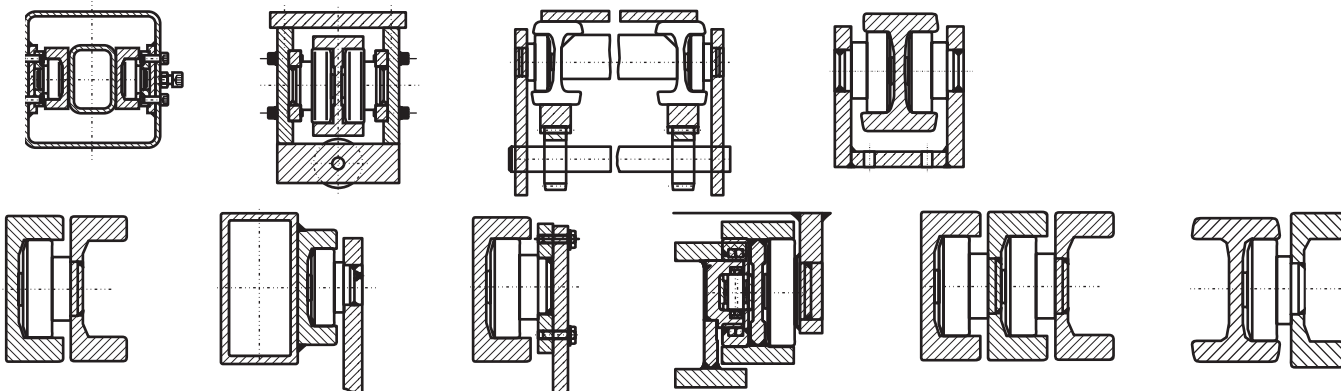

LIFTING UNITS

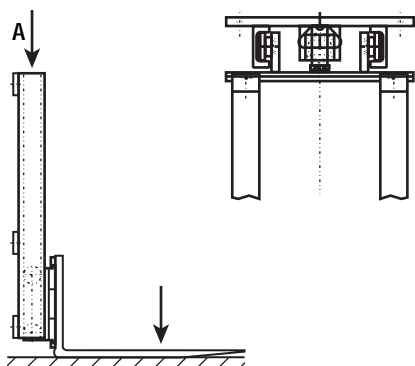

HORIZONTAL TELESCOPE



ADJUSTABLE CLAMP SYSTEM

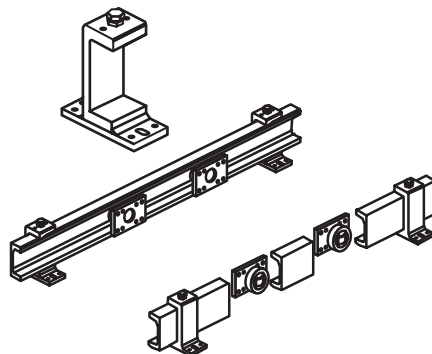

HANDLING UNITS

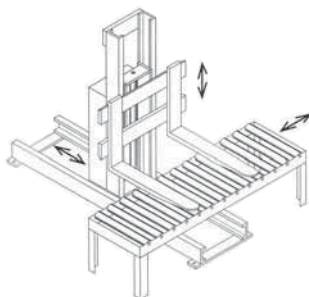

SYSTEM DESIGN SUGGESTIONS

1. The overall system clearance should be 1.524 mm to 3.048 mm

2. Verify that the Axial bearing is aligned parallel to the rail; especially in vertical operations.

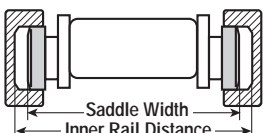

Inner Rail Distance = Saddle Width + (1.524 mm to 3.048 mm)



The data and specifications in this publication have been carefully compiled and are believed to be accurate and correct. However, it is the responsibility of the user to determine and ensure the suitability of Pacific Bearing® products for a specific application. Pacific Bearing's only obligation will be to repair or replace without charge, any defective components if returned promptly. No liability is assumed beyond such replacement. *Consult www.pacific-bearing.com for the latest technical updates.

Check our website for the current world-wide distributors at www.pacific-bearing.com

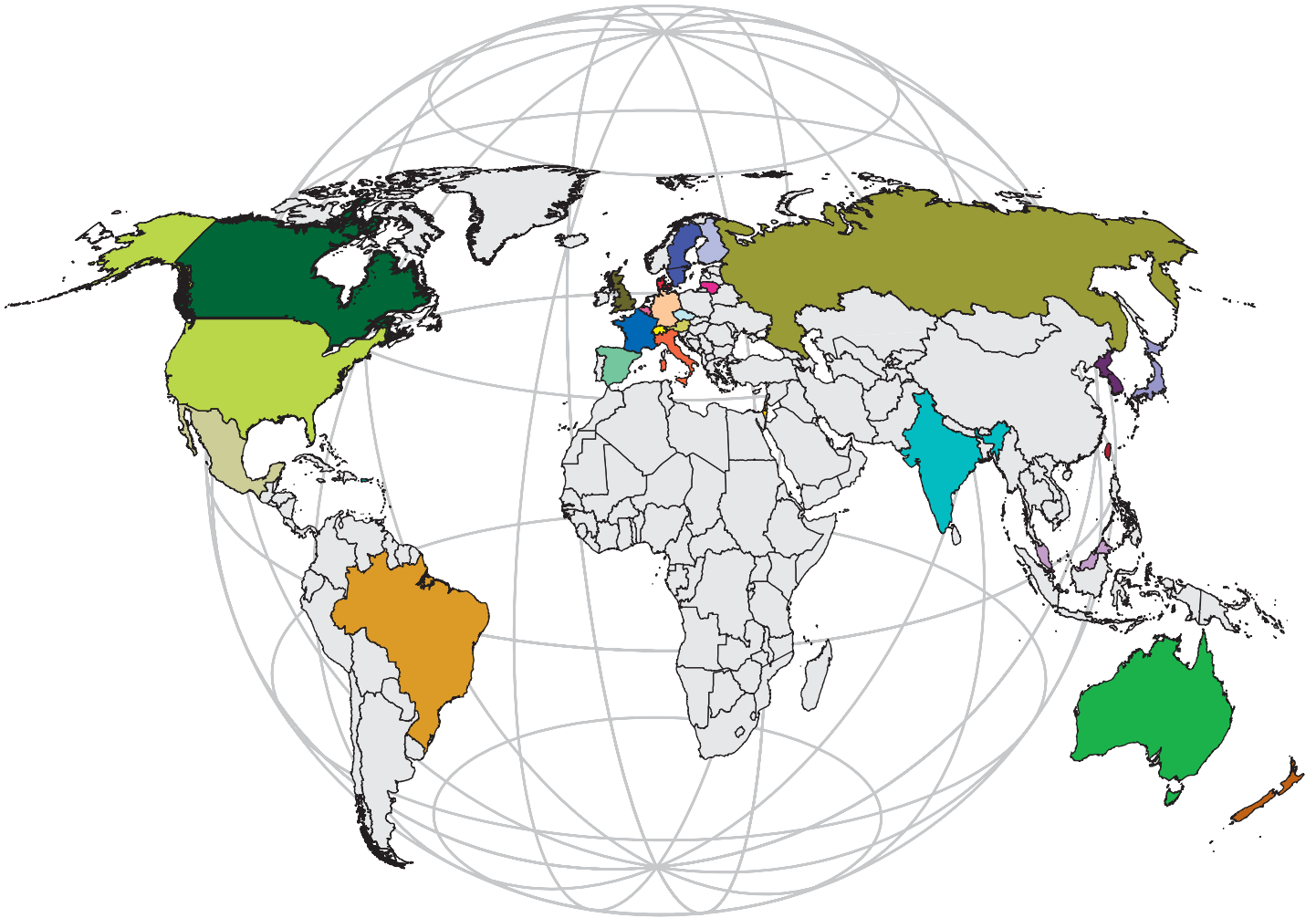

Locate the country nearest your location for the closest distributor

- | | | |
|----------------|-------------|----------------|
| Australia | India | Russia |
| Austria | Israel | Singapore |
| Belgium | Italy | Spain |
| Brazil | Japan | Sweden |
| Canada | Korea | Switzerland |
| Czech Republic | Lithuania | Taiwan |
| Denmark | Malaysia | United Kingdom |
| Finland | Mexico | United States |
| France | New Zealand | |
| Germany | Puerto Rico | |

The data and specifications in this publication have been carefully compiled and are believed to be accurate and correct. However, it is the responsibility of the user to determine and ensure the suitability of Pacific Bearing® products for a specific application. Pacific Bearing's only obligation will be to repair or replace without charge, any defective components if returned promptly. No liability is assumed beyond such replacement. *Consult www.pacific-bearing.com for the latest technical updates.

PACIFIC BEARING'S INNOVATIVE PRODUCT LINE-UP

Self-lubricating Linear Plane Bearings with engineered-to-match steel and ceramic coated shafting, pillow blocks, pre-drilled support rails, and integrated 1-piece rail and shaft.

- No lubrication required
- Tolerates temperature extremes
- Cannot catastrophically fail
- Fully interchangeable

simplicity®



Self-lubricating miniature linear guides

- Fully size interchangeable with industry standard sizes
- Lengths up to 3600 mm (12 ft.)
- No lubrication required
- Tolerates temperature extremes

mini-rail®



Combination axial and radial load heavy-duty rolling element bearings and rails

- Extremely High Load capacity up to 4.6 US Ton-force
- Longer service life for bearings and profiles
- Unlimited rail lengths available

Hevi-Rail®
Heavy Duty Bearing Systems



Rolling element linear guides, belt driven systems, drawer slides, and V-Guide Systems

- Cost effective solution for long travel and harsh environment applications
- Precision tolerances +/- .025 mm over entire rail length
- Simple design for fast, easy installation
- Lightweight, durable construction

redi-rail®



Self-lubricating guide systems

- Dampens vibration & shock loads
- Customize with ball or lead screws, belt drives & more
- No lubrication required
- Tolerates temperature extremes

dolphin guides®



An entrepreneurial mechanical engineer, Bob Schroeder, founded Pacific Bearing in 1983 with Simplicity®, the world's first self-lubricating plane bearing. Mr. Schroeder's vision was then, and still is today, to simplify linear motion applications and reduce costs for industrial motion control consumers worldwide. This ideal has been realized and embraced today by Pacific Bearing's employees that engineer, manufacture, market and sell innovative linear guide systems and components. In addition, Pacific Bearing has over 1,200 distributors and sales agents worldwide.

6402 Rockton Road • Roscoe, Illinois 61073 • Fax: 815.389.5790
800.962.8979 • www.pacific-bearing.com

LITLMS-B



SMOOTH & QUIET LINEAR MOTION™

PB-LMS-0407-50M