

# electron



# ronics



## ELECTRONICS

Motors .....	3-4
Sensors .....	3-12
Controllers .....	3-14

# Overview

## Two-phase stepper motors

3-4



MS 135HT-2  
MS 200HT-2



MS 300HT-2  
MS 600HT-2  
MS 900HT-2

## DC servo motors

brush / brushless

3-6

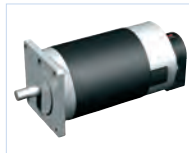

DC 100



EC 42

## EC servo motors

brushless

3-8



EC 60



EC 86

## Linear motors

3-10



iLM 25



iLM 50

## Magnetic length measuring system

3-12



iMS 10

## CNC control panels

3-14



iBP 19

## Drive modules

for 2-phase step motors

3-15



MD 24/28

## Drive controllers

3-16













iMD 10/20



iMD 30/40

# Overview

<b>PC controller</b>	 <p>iPC 15</p>	3-18
<b>CAN PCI board</b>	 <p>iCC 10 /20</p>	3-19
<b>CAN controller components</b>	 <p>CAN I-O modules</p>  <p>CPC 12</p>	3-20
<b>Step controller</b> Single axis controller	 <p>IT 116 Flash</p>	3-22
<b>Step controller</b> Multiple axis controller	 <p>iMC-P</p>  <p>iMC-S8</p>	3-23
<b>Servo controller</b> Single axis controller	 <p>MC 1-10 MC 1-20 MC 1-40</p>	3-25
<b>Servo controller</b> Multiple axis controller	 <p>iCU-DC / iCU-EC</p>  <p>iPU-DC/iPU-EC</p>	3-26
<b>CAN-CNC controller</b> Overview		3-28

# Two-phase stepper motors

## MS 135/200 HT-2



Two-phase stepper motor MS 135 HT - 2

### Features

- Step angle 1.8°, higher resolution through microstep mode
- Very high torque through rare earth magnets
- Optimised for use with position controllers
- Optimum torque/size ratio
- Smaller step angle errors, non-cumulative
- IP43 protection class
- **Optional:**
  - MD 24 drive module
  - Brake (MS 200 HT)
  - Second shaft end (MS 200 HT)

### General

Two-phase stepper motors behave similarly to synchronous motors. They are easy to control and are characterised by very long working life and reliability, at a favourable price. This results in a wide range of applications. Two-phase stepper motors in the MS range are of the high torque type. A particularly high torque is achieved by the use of rare earth magnets.

### Technical specification

Description	Holding moment bipolar Nm	Winding current per phase A	Winding voltage per phase V	Winding inductance per phase mH	Weight kg	Length (without shaft) mm	Part no.
MS 135 HT-2	1.1	3.0	2.4	2.4	0.7	56	<b>470551</b>
MS 200 HT-2	1.8	3.0	3.0	3.5	1.0	76	<b>470581</b>
MS 200 HT-2 (2nd shaft end)	1.8	3.0	3.0	3.5	1.1	76	<b>470581 0100</b>
MS 200 HT-2 (brake)	1.8	3.0	3.0	3.5	1.8	76	<b>470581 0200</b>

### Wiring diagram

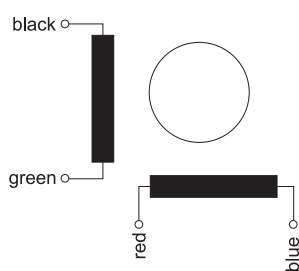

### Dimensioned drawing

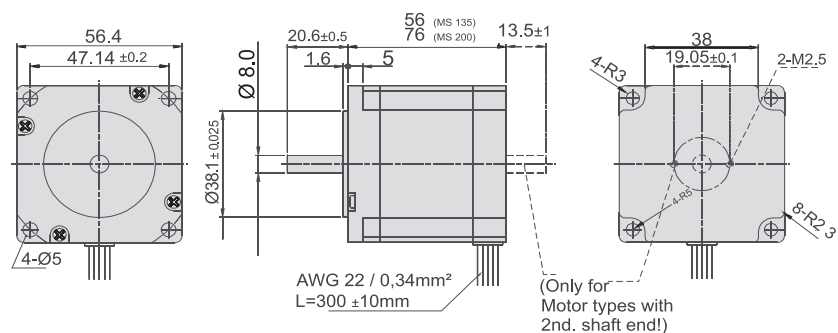

### Torque curves

MS 135 HT

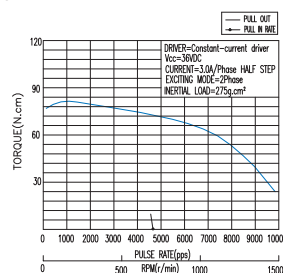

MS 200 HT

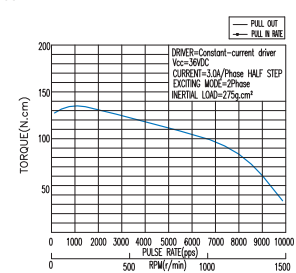

Subject to technical changes.

# Two-phase stepper motors

## MS 300/600/900 HT-2

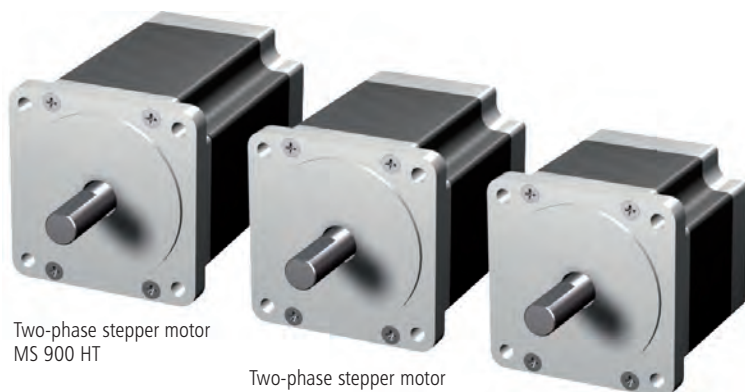

Two-phase stepper motor  
MS 900 HT

Two-phase stepper motor  
MS 600 HT

Two-phase stepper motor  
MS 300 HT

### Features

- Step angle 1.8°, higher resolution through microstep mode
- Very high torque through rare earth magnets
- Optimised for use with position controllers
- Optimum torque/size ratio
- Smaller step angle errors, non-cumulative
- IP43 protection class
- **Optional:**
  - MD 28 drive module
  - Brake (MS 300 HT)

### General

Two-phase stepper motors behave similarly to synchronous motors. They are easy to control and are characterised by very long working life and reliability, at a favourable price. This results in a wide range of applications. Two-phase stepper motors in the MS range are of the high torque type. A particularly high torque is achieved by the use of rare earth magnets.

### Technical specification

Description	Holding torque Bipolar Nm	Winding current per phase parallel/series A	Winding voltage per phase parallel/series V	Winding inductance per phase mH	Weight kg	Length (without shaft) mm	Part no.
MS 300 HT - 2	3.11	5.6 / 2.8	1.68 / 3.38	1.6	2.0	66	470821
MS 300 HT - 2 (brake)	3.11	5.6 / 2.8	1.68 / 3.38	1.6	2.75	104	470821 0200
MS 600 HT - 2	6.80	7.0 / 3.5	2.28 / 4.55	2.4	3.0	98	470851
MS 900 HT - 2	9.00	6.3 / 3.1	2.84 / 5.67	4.2	4.5	126	470881

### Wiring diagram

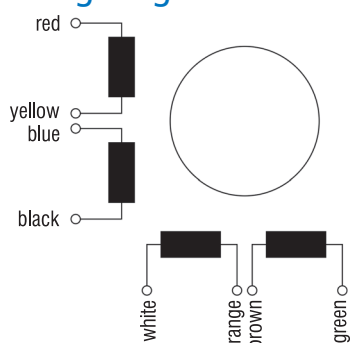

### Dimensioned drawing

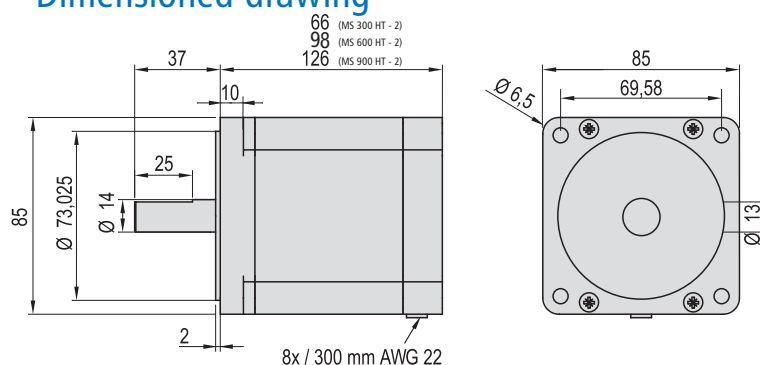

### Torque curves

MS 300 HT

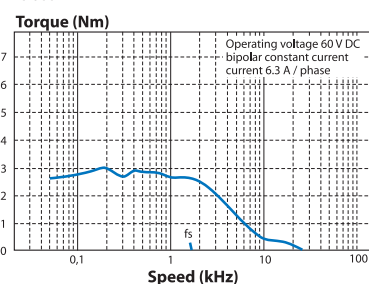

MS 600 HT

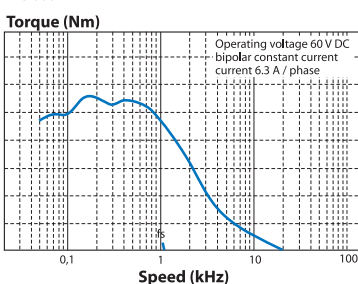

MS 900 HT

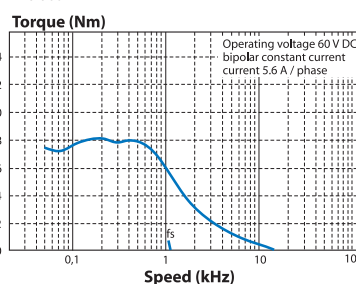

Subject to technical changes.

# Servo motors with brush drive

## DC 100

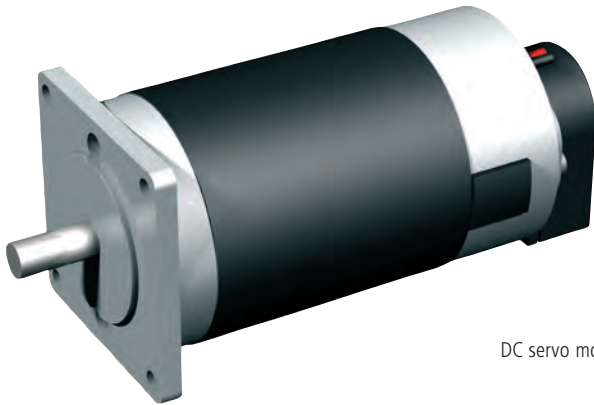

DC servo motor DC 100

### Features

- Servo motor with brushes
- Low-resistance winding construction
- Good dynamic response
- Two-finger brush (long working life)
- Incremental encoder with 512 pulses/turn
- IP43 protection class/IP50 encoder

### General

DC servo motors with brushes are the entry into the controlled drive technology class. They have good dynamic response and have proved themselves in drive systems. The attached encoder enables precise positioning. This predestines their use in CNC machines and in automation systems.

### Technical specification

Description	Voltage V	No-load speed rpm	No-load current A	Rated speed rpm	Rated torque Ncm	Rated current A	Rated output W	Peak current A	Part no.
DC 100	48	3,400	0.25	3,000	30	2.8	95	6.5	471022 0020

### Dimensioned drawings

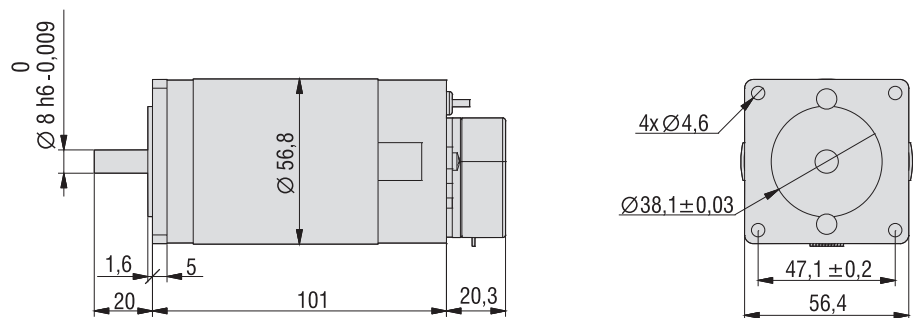

### Wire colours/ Pin assignments

#### Motor cable

Signal	Colour
Motor +	red
Motor -	black

#### Encoder cable

Pin	Signal	Colour
1	Gnd	black
2	Vcc +5 V	red
3	Encoder A	green
4	Encoder /A	brown
5	Encoder B	white
6	Encoder /B	grey
7	Encoder Z	yellow
8	Encoder /Z	orange

Plug connector: 8-pole female connector strip, type JST PHR-8

Subject to technical changes.

# Servo motors

with brushless drive

## EC 42



### Features

- Electronically commutated 3-phase-servo motor
- Brushless drive
- Compact configuration
- Incremental encoder with 512 pulses/turn, RS422
- Hall sensors
- Areas of application: positional control, speed control

### Technical specification

Part no.	Description	Rated output	Nominal voltage	Current	Number of poles	Rated speed	torque at rated speed	Peak torque	Length L	Weight
		W	V DC	A			Nm	Nm		
474062 0048	EC 42	62	48	1.75	8	3000	0.2	0.6	88	0.55

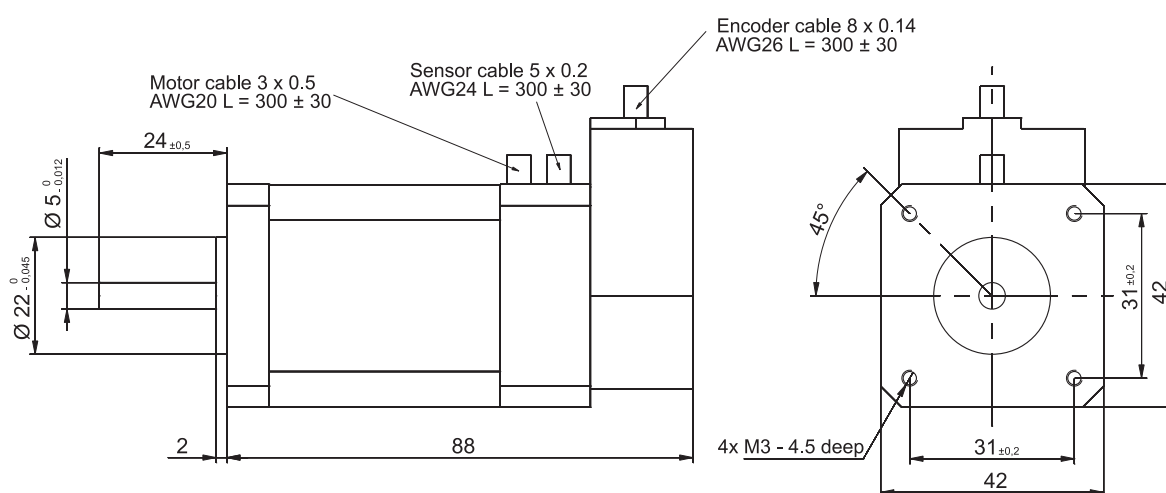

### Wire colours

#### Motor cable

Signal	Colour
Motor U	yellow
Motor V	blue
Motor W	green

#### Hall cable

Signal	Colour
Hall A	yellow
Hall B	green
Hall C	blue
Vcc +5 V	red
Gnd	black

#### Encoder cable

Signal	Colour
Encoder A	blue
Encoder /A	blue/black
Encoder B	green
Encoder /B	green/black
Encoder Z	yellow
Encoder /Z	yellow/black
Vcc +5 V	red
Gnd	black

Subject to technical changes.



# Servomotors

with brushless drive

## EC 60



### Features

- Electronically commutated 3-phase servomotor
- Brushless drive
- High output performance concurrently with compact build
- Incremental encoder with 512 pulses/turn, RS422
- Hall sensors
- IP44 protection class
- Uses: Positioning and speed control
- Connection via circular plug
- Option: Brake

### General

Brushless EC motors are designed as electronically switched 3-phase synchronous motors. Compared with brush drives, these motors have an even longer working life, because they are subjected to less wear. Moreover, in this case, high power density and dynamic response relative to size must be emphasized. These motors are used in many automation technology areas and in CNC machines.

### Technical specification

Part no.	Description	Rated output W	Rated voltage V DC	Current A	Number of poles	Rated speed rpm.	Torque at rated speed Nm	Peak torque Nm	Length L (mm)	Weight kg
474156 0048	EC 60S	156	48	6.9	8	3,000	0.5	1.75	73	1.25
474156 1048	EC 60S with brake	156	48	6.9	8	3,000	0.5	1.75	73	2.0
474235 0048	EC 60L	235	48	10.5	8	3,000	0.75	2.25	94	1.6
474235 0310	EC 60L	235	310	1.6	8	3,000	0.75	2.25	94	1.6
474235 1310	EC 60L with brake	235	310	1.6	8	3,000	0.75	2.25	94	2.35

### Dimensioned drawings

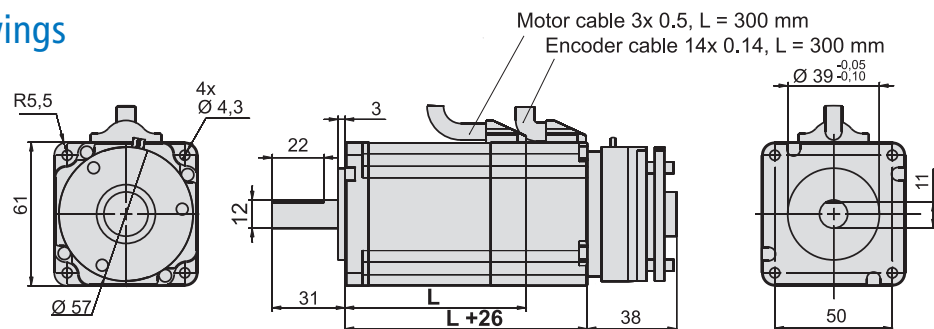

### Wire colours/ Pin assignments

#### Motor cable

Signal	Colour
Motor U	yellow
Motor V	blue
Motor W	green
PE	green/yellow

#### Encoder cable

Pin	Signal	Colour
1	Shield	Shield
2	Gnd	black
3	Vcc +5 V	red
4	Encoder B	grey
5	Encoder /B	grey/black
6	Encoder A	brown
7	Encoder /A	brown/black
8	Encoder Z	orange
9	Encoder /Z	orange/black
10	Hall A	yellow
11	Hall B	white
12	Hall C	green

Encoder cable plug connector:  
12-pole female connector strip, type JST PHR-12

Subject to technical changes.

# Servomotors

with brushless drive

## EC 86



### Features

- Electronically commutated 3-phase servomotor
- Brushless drive
- High output performance concurrently with compact build
- Incremental encoder with 512 pulses/turn, RS422
- Hall sensors
- IP44 protection class
- Uses: Positioning and speed control
- Connection via circular plug
- Option: Brake

### General

Brushless EC motors are designed as electronically switched 3-phase synchronous motors. Compared with brush drives, these motors have an even longer working life, because they are subjected to less wear. Moreover, in this case, high power density and dynamic response relative to size must be emphasized. These motors are used in many automation technology areas and in CNC machines.

### Technical specification

Part no.	Description	Rated output W	Rated voltage V DC	Current A	Number of poles	Rated speed rpm.	Torque at rated speed Nm	Peak torque Nm	Length L mm	Weight kg
474440 0310	EC 86S	440	310	3.4	8	3,000	1.4	5.0	100	2.6
474660 0310	EC 86L	660	310	3.6	8	3,000	2.1	7.4	125	4

### Dimensioned drawings

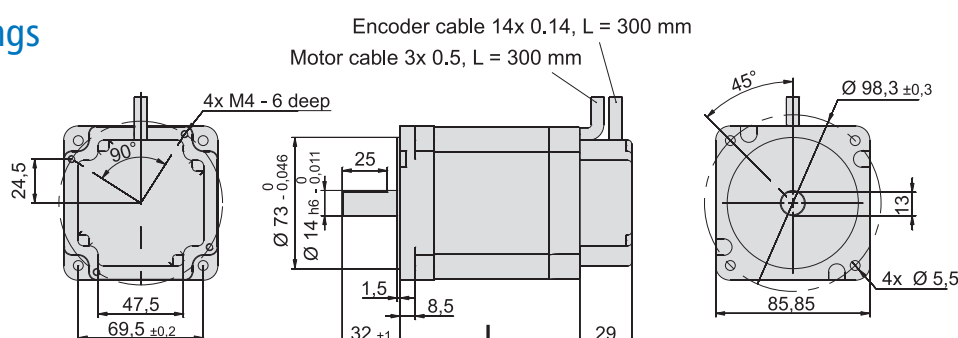

### Wire colours/ Pin assignments

#### Motor cable

Signal	Colour
Motor U	yellow
Motor V	blue
Motor W	green
PE	green/yellow

#### Encoder cable

Pin	Signal	Colour
1	Shield	Shield
2	Gnd	black
3	Vcc +5 V	red
4	Encoder B	grey
5	Encoder /B	grey/black
6	Encoder A	brown
7	Encoder /A	brown/black
8	Encoder Z	orange
9	Encoder /Z	orange/black
10	Hall A	yellow
11	Hall B	white
12	Hall C	green

Encoder cable plug connector:  
12-pole female connector strip, type JST PHR-12

Subject to technical changes.

# Linearmotoren

## LS winding package with MS magnetic rail

## iLM Serie

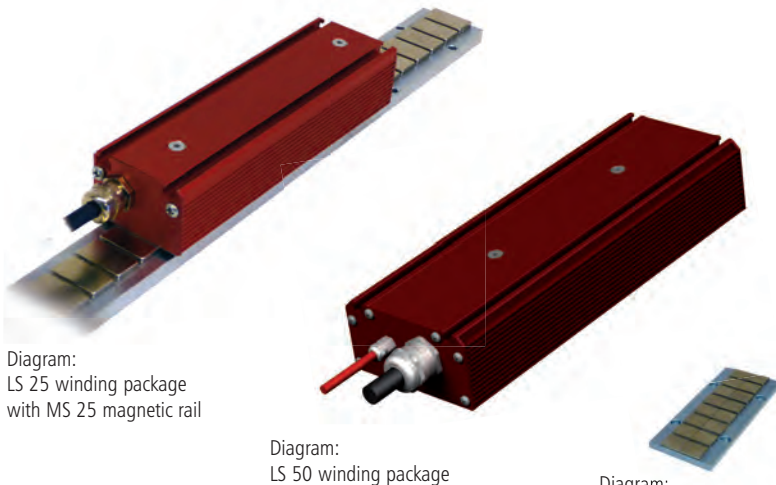

Diagram:  
LS 25 winding package  
with MS 25 magnetic rail

Diagram:  
LS 50 winding package

Diagram:  
MS 25 magnetic rail  
with 8 magnets

### Features

- Ready-for-installation systems comprising primary part (LS winding package) and secondary part (MS magnetic rail)
- Compact build
- High acceleration
- High speed and dynamic response
- High efficiency
- Free from wear
- Custom motor length
- Secondary part (MS magnetic rail): Elements of any length, depending on their carrier system, can be arranged in rows
- Controllable with standard servo converters

### Optional:

- iMD 40 drive controller (only in conjunction with Hall board)
- Magnetic length measurement system
- Linear guides

## General

Linear motors in the iLM series are linear 3-phase servomotors of various sizes and any length at a favourable price/performance ratio. The optionally integrated Hall sensors provide the positional information for switching the motor. There is a PTC temperature sensor in the primary component to protect the motor. The electrical connections (Hall, windings and temperature sensor) are made via permanently installed cable. Owing to the direct power transfer, there is no need for any mechanical transfer elements, such as spindles and toothed belts which completely eliminates friction and play. This means that higher speeds and dynamic responses can be achieved. The resultant lower clocking times reduce production costs and increase productivity. Because there are no mechanical elements in the drive itself, noise, wear and the resultant maintenance costs are minimised. In comparison with other linear drives, drives with linear motors are more accurate, faster, free from play (without return play) and more robust.

## Ordering information

Winding package

**486 0XX 000X**

Coil package

0 = LS 25

1 = LS 50

Hall boards

0 = without Hall board

1 = with Hall board

Number of coils

1 = 3 coils

2 = 6 coils

3 = 9 coils

4 = 12 coils

Note:

For the iMD 40 drive controller use coil packages with Hall boards only.

Any number of magnetic rails can be arranged with each other.

Magnetic rails

MS 25 magnetic rail with 8 magnets (L×W×H approx.124/45/11mm)

Part no.: **486100 01241**

MS 25 magnetic rail with 32 magnets (L×W×H approx.496/45/11 mm)

Part no.: **486100 04961**

MS 50 magnetic rail with 8 magnets (L×W×H approx. 200/80/11 mm)

Part no.: **486110 0200**

MS 50 magnetic rail with 16 magnets (L×W×H approx. 400/80/11 mm)

Part no.: **486110 0400**

MS 50 magnetic rail with 32 magnets (L×W×H approx. 800/80/11 mm)

Part no.: **486110 0800**

- LS 25 coil package with 6 coils and Hall boards
- + 2× MS 25 magnetic rails with 32 magnets
- + iMD 40 drive controller
- + iMS-I magnetic length measuring system (5 μm resolution)

Part no.: **486001 0002**

Part no.: **486100 0496**

Part no.: **314040**

Part no.: **390255 4412**

Subject to technical changes.

# Linearmotoren

## LS winding package with MS magnetic rail

# iLM Serie

## Technical specification

	Intermediate circuit voltage [V] **	Number of coils	Rated current [A]	Peak current [A]	Feed force [N]	max. feed force [N]	max. tensile force [N]*	Rated speed [m/s] at rated current
LS 25/6 coils	330	6	2.6	6.5	70	170	500	6.6
LS 25/12 coils	330	12	2.6	6.5	140	340	1,000	4.0
LS 50/6 coils	330	6	6.0	15.0	285	675	1,995	5.1
LS 50/12 coils	330	12	6.0	15.0	570	1,350	3,990	3.5

\* Higher intermediate circuit voltage to order.

\*\* Applicable for a working air gap of 0.8 mm.

## Dimensioned drawings

iLM 25 linear motor

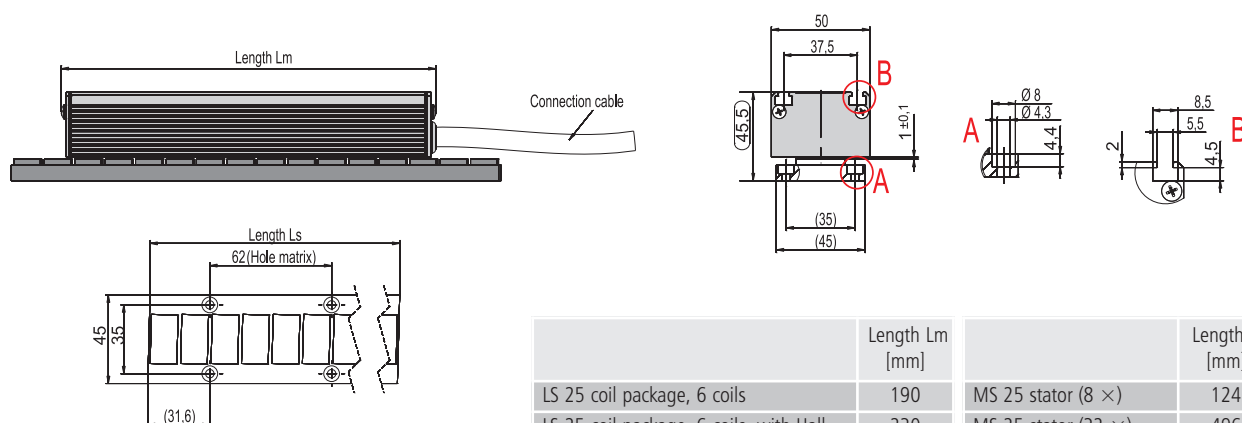

	Length Lm [mm]		Length Ls [mm]
LS 25 coil package, 6 coils	190	MS 25 stator (8 ×)	124
LS 25 coil package, 6 coils, with Hall	230	MS 25 stator (32 ×)	496
LS 25 coil package, 12 coils	365		
LS 25 coil package, 12 coils, with Hall	405		

iLM 50 linear motor

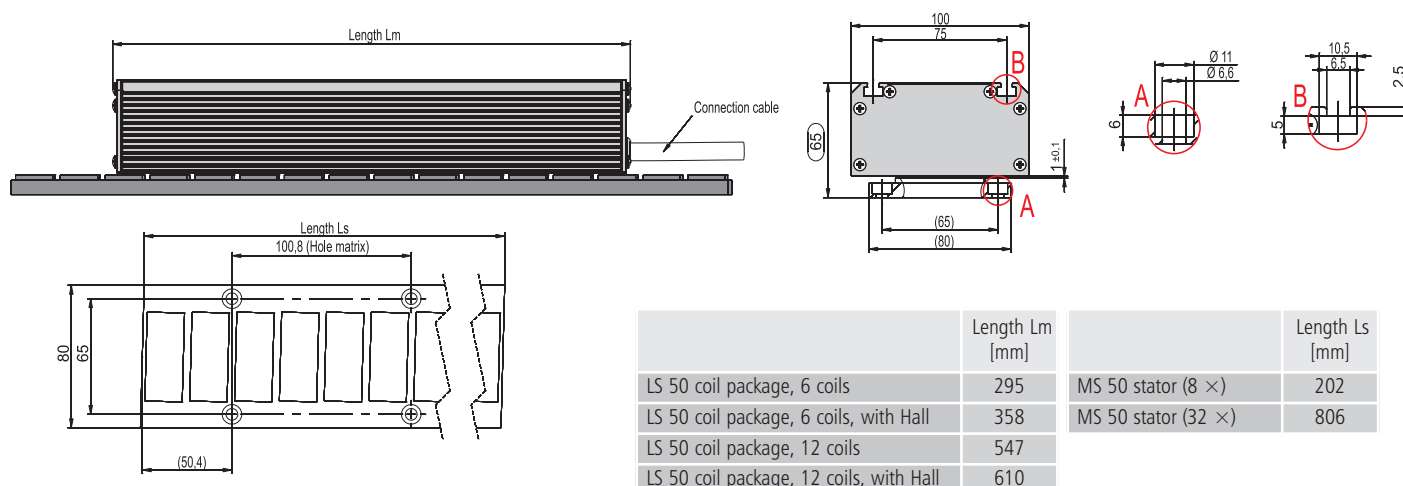

	Length Lm [mm]		Length Ls [mm]
LS 50 coil package, 6 coils	295	MS 50 stator (8 ×)	202
LS 50 coil package, 6 coils, with Hall	358	MS 50 stator (32 ×)	806
LS 50 coil package, 12 coils	547		
LS 50 coil package, 12 coils, with Hall	610		

Subject to technical changes.

# iMS magnetic length measuring system

Detailed  
information

under  
[www.isel-germany.de](http://www.isel-germany.de)



Diagram:  
iMS magnetic length measuring system

## Features

- Measuring head with sensor in stable casing
- Reliable, robust, good value
- 2 channels, A and B, difference mode incremental RS 422 or difference mode analogue 1VSS
- Incremental/digital resolution (see table)
- Repeatability =  $\pm 1$  increment
- Magnetic tape on self-adhesive, stainless steel bearer tape

optional:

- Reference pulse

## General

The iMS contactless magnetic measuring system relies on scanning a magnetically coded measuring tape by means of a magnetically sensitive sensor and is suitable for detection of both linear and radial positions. A decisive advantage compared with significantly more expensive optical systems is provided by its insensitivity to contamination caused by liquids, greases and dust. Our length measuring system is therefore a cost-effective alternative to other systems on the market.

Available sensor interfaces for further processing in the peripherals are, optionally, a pulse sensor with incremental RS422 AB output (Z optional) and a SIN/COS/(Z optional) sensor with voltage amplitude 1Vss.

## Ordering data

iMS-I magnetic length measuring system  
in casing  
Resolution  $5\mu\text{m}$ , edge interval  $0.55\mu\text{s}$ ,  
Processing speed 5.25 m/s  
Part no.: **390255 4412**

Magnetic tape on self-adhesive stainless  
steel bearer tape (2 mm pole pitch, 10 mm  
wide, 1.3 mm thick)  
Part no.: **563150**

## dimensioned drawing

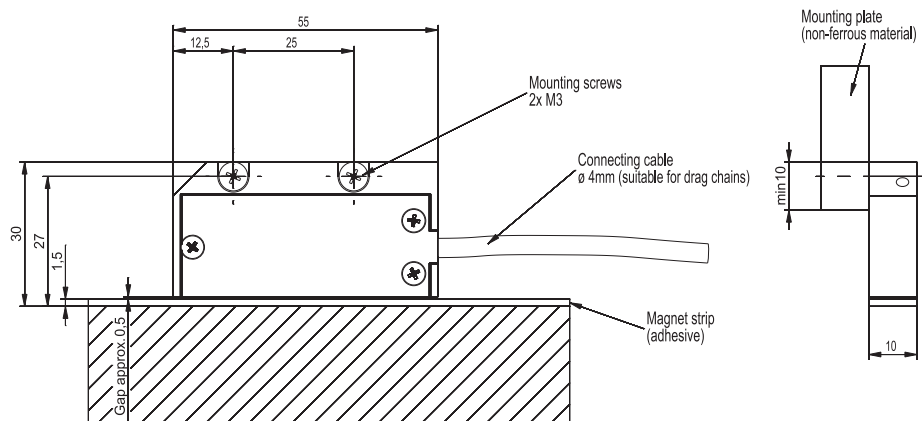

Subject to technical changes.

# iMS magnetic length measuring system

## Technical specification

### Sensor

Mechanical specification	
Casing	Aluminium
Weight	approx. 70g
Sensor lead	PUR
Cable bending radius	>10 mm, first bend > 10 mm from sensor casing
Electronic data	
Supply voltage	4.9V - 5.1V (optional: 7V - 15V)
Current drain	< 100 mA on no load
Output signals	Standard RS422 A, /A, B, /B optional reference Z, /Z Option: SIN/ COS 1V <sub>ss</sub> +20%, -40%, Z und /Z right sign
Termination	Terminating resistor = 120 Ohm between corresponding output signals, e.g. A - /A, at receiver
Sensor distance - magnetic tape	0.4 - 0.7 mm
Sensor resolution incremental	1 $\mu$ m, 2.5 $\mu$ m, 5 $\mu$ m, 10 $\mu$ m, 20 $\mu$ m
Pulse interval	0.25 $\mu$ s, 0.55 ns, 1 $\mu$ s, 2 $\mu$ s, 4 $\mu$ s, 8 $\mu$ s
Analogue sensor resolution	Sinusoidal period length = 2 mm
maximum speed	< 10 m/s, higher on request
Repeat accuracy	Incremental resolution $\pm$ 1 increment, plus errors due to angular tilting in the 3 sensor axes
accuracy	Measurement error 20 $\mu$ m, plus errors due to angular tilting in the 3 sensor axes
Reference sequence	optional: NSN (special order)
Ambient conditions	
Operating temperature	-5°C to 80°C
Storage temperature	-20°C to 100°C
Air humidity (only sensor)	100%, dewing allowed

### Normal measurement - magnetic tape

operating temperature	-5°C to 80°C
Material	High quality stainless steel, coding bearer elastomer, self-adhesive
Thickness	1.3 mm $\pm$ 0.15 mm + bonding layer 0.13 mm, optional: 0.1 mm stainless steel tape + 0.2 mm bonding layer
Width	10 mm
Length	up to 50m on roll
Pole pitch/PITCH	2 mm, i.e. north pole = 2 mm, south pole = 2 mm magnetic period = 4 mm
Number of tracks	Single track, 10 mm wide Option: signal track 5 mm, reference track periodically 5 mm
accuracy	$\pm$ 0.04mm/m up to 50 m length, at 20°C
Coefficient of expansion	17E-6 m/Kelvin
Ambient conditions	
with no or minimum effect on the measurement norm	Chemical resistance to contamination with motor oil, gearbox oil, ATF, hydraulic oil, kerosene, antifreeze, Clorox disinfectant, turpentine, water, brine. The materials listed have no or little effect on the long term stability of the measurement standard; this depends, among other things, on the concentration, the temperature and the time of the contamination. Please check your own case.
little/average effect on the measurement standard	Jet petrol, carburettor fuels, heptanes, alcohols
strong effect on the measurement standard	Aromatic hydrocarbons, ketones, inorganic acids

# CNC control panels

# iBP 19

Figure:  
iBP 19-1 with wall bracket  
and silicon keyboard



Figure:  
iBP 19-2 with bench mounting and stainless steel keyboard

Figure:  
iBP 19-1 with stand  
and silicon keyboard

## Features

### iBP 19-1

- 19" TFT touch screen display
- 102 keys, silicon keyboard (IP65) with integrated 2-key mouse pointer or mouse carrier plate fixed to the side
- Dimensions: 475 x D 501 x H 354 mm
- Weight: appr. 17.4 kg

### iBP 19-2

- 19" TFT touch screen display
- 102 keys, stainless steel keyboard (IP65) with integrated 2-key trackball
- Dimensions: W 475 x T 501 x H 354 mm
- Weight: appr. 18.4 kg

## General

CNC control panels are robust and powerful control units for an extensive range of applications in industrial automation and much more. A conventional external PC can be connected and operated with the standard connections provided. All CNC control panels come with an integrated touch screen monitor, a keyboard and a control panel with stainless steel keys and 2-channel emergency shutdown switch for operating CNC machines. The extensive range of installation options cater to both wall and bench mounting. Three different versions are available.

## Common features

- stable metal casing with aluminium front plate
- pivoted with wall and bench mounting
- simple connection of external PC systems
- Touch screen monitor
- robust and tamper-proof casing
- Control panel with stainless steel keys
- 2-channel emergency shutdown switch

## Ordering information

19" CNC control panel iBP 19-1, German silicon keyboard	Part no.: <b>371076 1102</b>
19" CNC control panel iBP 19-1, English silicon keyboard	Part no.: <b>371076 1112</b>
19" CNC control panel iBP 19-2, German steel keyboard	Part no.: <b>371077 1102</b>
19" CNC control panel iBP 19-2, English steel keyboard	Part no.: <b>371077 1112</b>
Mounting arm for wall mounting iBP 19	Part no.: <b>371050 0003</b>
Mounting arm for bench mounting	Part no.: <b>371050 0004</b>
Stand iBP 19	Part no.: <b>371050 0005</b>
Mounting arm for rack assembly iBP 19 on PS 80	Part no.: <b>371050 1009</b>
Mounting arm for rack assembly iBP 19 on PS 100	Part no.: <b>371050 1010</b>
Mounting arm for rack assembly iBP 19 on PS 140	Part no.: <b>371050 1008</b>

Subject to technical changes.

# Drive modules MD 24/28

## for 2-phase step motors



### Features

- High performance, low noise
- Power supply up to 50 V DC (80 V DC)\*
- Output current up to 4.2 A (7.8 A)\*
- Automatic current reduction
- Suitable for 2-phase and 4-phase stepper motors
- Clock / direction interface
- Input frequency for clock input up to 300 kHz
- 15 (14)\* selectable resolutions up to 25,600 steps/rev (51,200 steps/rev)\*
- Opto-isolated, TTL-compatible inputs
- Protection against short-circuit, overvoltage and overcurrent

\* MD 28

### General

The step motor drive modules MD24/MD28 are powerful final stages for 2-phase and 4-phase step motors. The modules are micro-step capable and thus allow very quiet running of the connected motors. Due to its particular chopper technology for the motor current, identical motors can deliver higher speeds and torques than conventional, comparable drive modules. The clocking/direction interface also allows simple connection to various motion controllers or a PLC.

### Technical specification

Parameter	Unit	MD 24			MD 28		
		Min.	Typical	Max.	Min.	Typical	Max.
Output current	A	1	-	4.2 (3.0 A rms)	2.8	-	7.8
Mains voltage	VDC	20	36	50	24	68	80
Current logic signals	mA	7	10	16	7	10	16
Clocking input frequency	kHz	0	-	300	0	-	300
Insulation resistance	MΩ	500			500		
Part no.		316303			316304		

### Dimensioned drawings

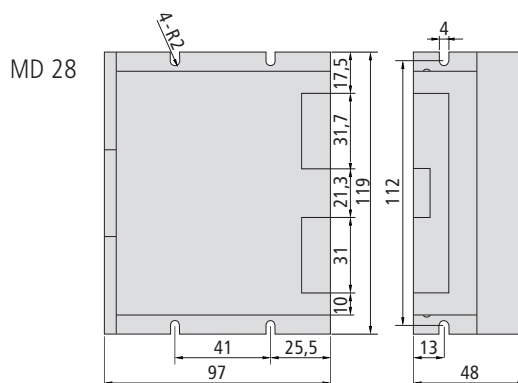
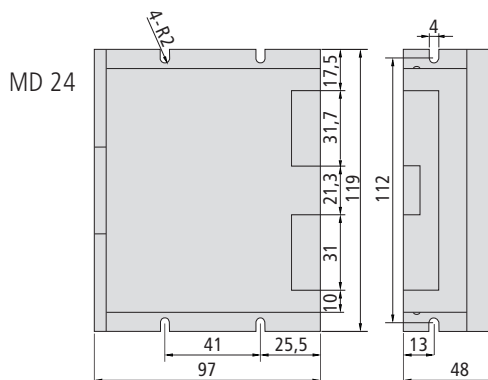

Subject to technical changes.

Subject to technical changes.



# Drive controller

for stepper and servo motors

## iMD 10/20/30/40



iMD 10

iMD 20

iMD 30

iMD 40

### General

The **iMD10/20/30** series of drive controllers are economical final stages for DC motors (iMD10) and EC servomotors (iMD20) as well as for two-phase step motors (iMD30). The fully digital **iMD40** drive controller is an economical final stage, powered directly from the mains, for EC servomotors (synchronous motors, such as linear or torque motors) up to 2 kW.

Typical applications are CNC machines and automation systems. The final stage casings are optimised for cabinet installation. The extensive configuration options allow flexible adaptation to a wide range of applications and all required settings can be made with a user-friendly commissioning software package.

There are various user interfaces available for integration with proprietary applications. Here, the CAN open interface must be emphasized. In addition to synchronous point-to-point positioning (S-PTP) and speed control, track control (CP -Continuous Path) and synchronised multiple axis applications are feasible using the implemented CANopen protocol DS402. Additional interfaces include a  $\pm 10V$  interface (nominal speed) and a RS232 interface. The iMD30 also has a clocking/direction interface.

Short controller cycle times (current, speed, position controller) ensure optimum performance for highly dynamic drives. The drive controllers are suitable both for rotary drives and for the corresponding linear direct drives and torque motors (iMD20 and iMD40). A redundant rest monitoring system has been integrated in the drive controller. It reduces work by the controller in external assemblies to a minimum and allows for convenient operation or use of the machine.

# Drive controller

for stepper and servo motors

# iMD 10/20/30/40

## Technical specification

Features	iMD 10	iMD 20	iMD 30	iMD 40
Motor type	Brush servomotors (DC)	Brushless servomotors (EC, BLDC)	Two-phase step motors (ST)	Brushless servomotors (DC, BLDC)
Power supply	40-95 V DC			230V AC, mains, single phase
Motor current	Constant current 12 A, peak current 25 A		Constant current 12 A	Constant current 6.5 A Peak current 8 A
CAN bus interface	CANopen DS301 V4.0 and DS402 V1.0 der CiA (CAN in automation)			CANopen DS301 V4.0 and DS402 V1.0 of CiA (CAN in automation)
RS-232 interface (asynchronous, 19.2 or 57.6 kbits/s).	For commissioning (DcSetup.exe) or e.g. PLC connection; effective data transfer protocol	For commissioning (AcSetup.exe) or e.g. PLC connection; effective data transfer protocol	For commissioning (StepSetup.exe) or e.g. PLC connection; effective data transfer protocol	For commissioning (AcSetup.exe) or, e.g. PLC connection; effective data transfer protocol
Measuring system	Incremental encoder (RS422); max. input frequency: 1.25 MHz		--	Incremental encoder (RS422); max. input frequency: 1.25 MHz
Commutation	--	Hall sensor signals	--	Hall sensor signals
Analogue input ( $\pm 10V$ )	11 bit resolution			11 bit resolution
PWM switching frequency	max. 12.5 kHz	max. 16.4 kHz	max. 10.0 kHz	max. 16.4 kHz
Inputs for limit and reference switches	✓	✓	✓	✓
Digital current, speed and position control	Scanning times: min. 80 $\mu s$ /244 $\mu s$ /488 $\mu s$ for current/speed/position controllers	Scanning times: min. 61 $\mu s$ /244 $\mu s$ /488 $\mu s$ for current/speed/position controllers	Scanning times: min. 100 $\mu s$ for current controllers	Scanning times: min. 61 $\mu s$ /244 $\mu s$ /488 $\mu s$ for current/speed/position controllers
Brake controller	✓	✓	✓	✓
Gantry mode or synchronous control	of 2 modules, Master-Slave via CAN bus			
Monitoring of the motor current	Short circuit, I <sup>2</sup> t	Short circuit, I <sup>2</sup> t, Pulse-by-pulse	Short circuit	Short circuit, I <sup>2</sup> t, Pulse-by-pulse
Monitoring of the encoder signals	✓	✓	--	✓
Monitoring of the software by internal Watchdog timer	✓	✓	✓	✓
Simple update of the firmware over RS-232	Possible locally by customer or service engineer			
Rest state monitoring	Redundancy to ISO standard			
Dimensions	180 x 35 x 110 mm	180 x 35 x 120 mm	180 x 35 x 110 mm	180 x 50 x 150 mm
Part no. Drive controllers	<b>314 020</b>	<b>314 030</b>	<b>314 070</b>	<b>314 040</b>

Motor and encoder connecting leads are NOT included in delivery.

Subject to technical changes.

# PC controller

# iPC 15



Figure:  
iPC 15 PC controller with blind panel and with possible connection alternatives

## General

The iPC15 universal PC controller is a Windows- or Linux-compatible controller at a favourable price/performance ratio. Its versatile applications may be found throughout the entire industry sector and in various consumer sectors.

All connections are made on the front. The multifunctional panel offers a wide range of connection options.

Inter alia, a CAN interface with either 1 or 2 channels is available.

A remote interface is available for covered installation (e.g. in a cabinet or in the interior of a motor vehicle).

Installation is possible both in the "standing" and "lying" positions.

## Technical specification

	<b>iPC15 PC controller</b>
CPU	Intel® Atom N270
Form factor mainboard	Mini-ITX (half height)
RAM	DDR2 SO DIMM 1GB (bis zu 2GB)
Hard disks (S-ATA)	2½ inches ≥ 160 GB
Graphics	Intel GMA 950
Monitor	VGA/DVI-D
Audio	Realtek® ALC662 audio codec
LAN	10/100/1000 Mbit LAN
Power supply	12 V DC
External connections (Basic version - with blind panel)	USB 2.0, LAN VGA, DVI-D Audio multifunction connection 12 V DC power supply
Internal interfaces	1 × PCI (without CAN interface) 1 × mini PCI Express, 1 × IDE 2 × SATA (1 x with HDD) USB 2.0 (3 × with SSD), 1 × parallel interface, 2 × serial interface, 1 × PS/2, 1 × SPDIF
Humidity	Max. 90% (non-condensing)
Ambient temperature	0°C to 35°C
Protection class	IP 20
Weight	1.1 kg
Dimensions (W×H×D)	200 x 50 x 190 mm

## Features

- Universal PC controller
- Robust, impact-proof aluminium casing
- Compact configuration
- Various installation options
- Energy-efficient and low noise
- Supply voltage 12V DC
- Front multifunctional panel for versatile connection options
- Design with hard disk or solid state disk (optional)
- Windows- and Linux-compatible

## Ordering information

Part no.: **371064 0011** - CAN  
Part no.: **371064 0007** - serial

Subject to technical changes.

# CAN PCI board

# iCC 10/20



Figure:  
Single channel



Figure:  
2 channels

## General

CAN-PCI boards offer a simple solution for connecting a CAN bus to the PCI bus system of a PC (e.g. iPC 15).

A driver software package is supplied with the board, which controls the entire CANopen communication with the application interface (e.g. ProNC) and also provides a programming interface for your own software.

The board can also be used in conjunction with CoDeSys V2.3.

The software package also includes configuration software which can be used to install the default settings for the CAN parameters (CANset).

## Technical specification

	iCC 10/20
Interface	PCI V2.2/32 bit
CAN channels	40910
galvanic isolation	✓
Data transfer rate of	up to 1 Mbits/s
RJ45	connector

## Features

- Mechanical dimensions: 119.5 × 47.3 mm
- PCI-V2.2-compliant
- 32-bit, 33 MHz target interface chip
- 1 or 2 RJ45 CAN channel connectors, screened
- CAN bus galvanically isolated
- Data transfer rate of up to 1 Mbit/s
- Drivers for NT/2000/XP/Vista
- Driver software for isel-CAN-CNC Controller
- Driver for CoDeSys available
- PDO and SDO communication via supplied DLL
- Can be used as CANopen master for a wide range of applications

## Block figure CAN bus with iPC 15

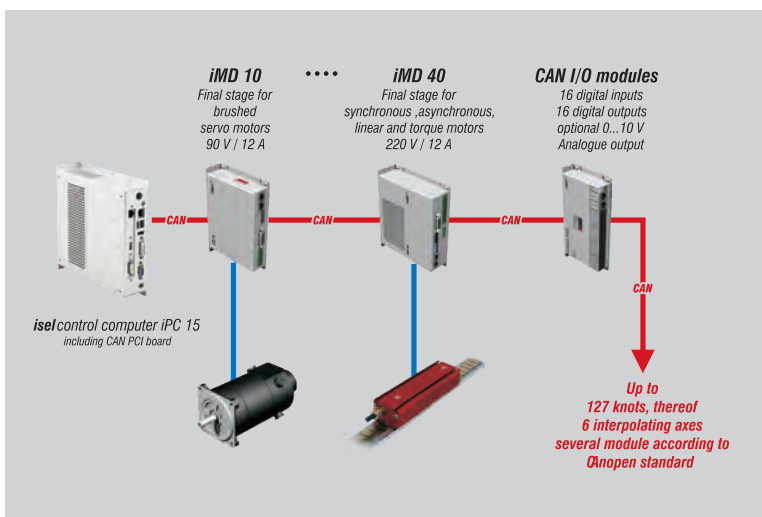

Subject to technical changes.

## Ordering information

CAN PCI board iCC 10  
Part no.: **320310** (Single channel)

CAN-PCI-Karte iCC 20  
Part no.: **320311** (2 channels)

# CAN controller components



CAN I/O module 16/16

CAN I/O module 8/12 - 4/1

## General

Both isel CANopen I/O modules provide an entry level into the world of modern industrial automation. They enable installation on site or in a cabinet.

A 24V DC power supply, galvanic isolation of the inputs and outputs and the terminals available directly on the module provide a great range of operating possibilities.

Connection via plug-in terminals and the status display assigned directly to the connection make for particularly user-friendly installation and servicing.

## Technical specification

	CAN I/O module 16/16	CAN I/O module 8/12 -4/1
Digital inputs	16 via optical coupler (Input current approx. 8 mA)	8 via optical coupler (Input current approx. 8 mA)
Digital outputs	16 8 × relays, I <sub>max</sub> < 5A 8 × electronically, I <sub>max</sub> < 350 mA	12 4 × relays, I <sub>max</sub> < 5A 8 × electronically, I <sub>max</sub> < 350 mA
Analogue output	1 0V - 10V via 8-bit D/A converter <small>(when using the analogue output, the electronic outputs are no longer available for use)</small>	1 0V - 10V via 8-bit D/A converter
Analogue input	--	4 0V - 10V, 10-bit resolution
Protection class	IP20	
Supply voltage	24V DC (logic voltage), 24V DC (process voltage),	
Power consumption	160 mA (logic and relays) <small>I<sub>load</sub> is dependent on the external wiring</small>	
Ambient temperature	-5°C to +40 °C	
Storage temperature	-25°C to +70 °C	
Relative humidity	max 95 %	
Protection class	IP20	
Weight	260 g	
Casing size	85 × 180 × 28 mm (W × H × D)	
Part no.	<b>321002</b>	<b>321004</b>

## Features

### CAN I/O module 16/16

- 16 digital inputs via optical coupler (input current approx. 8 mA)
- 16 digital outputs, 8 × relays, I<sub>max</sub> < 5A, 8 × electronically, I<sub>max</sub> < 350 mA (thermal protection, short circuit protection)
- One analogue output, 0 V - 10 V via 8-bit D/A converter (users of an analogue output can no longer use the electronic outputs)

### CAN I/O module 8/12 - 4/1

- 8 digital inputs via optical coupler (Input current approx. 8 mA)
- 12 digital outputs, 4 × relays, I<sub>max</sub> < 5A, 8 × electronic, I<sub>max</sub> < 350 mA (thermal protection, short circuit protection)
- One analogue output, 0 V - 10 V via 8-bit D/A converter
- 4 analogue outputs, 0 V - 10 V 10-bit resolution

Subject to technical changes.

# CAN controller components



Universal CAN positioning module  
CPC 12, with  $\pm 10V$  output

## General

The CAN CPC12 positioning module serves adaptation of drive controllers from various other manufacturers with  $\pm 10V$  interface to the CAN CNC controller.

This enables - in addition to CAN drive controllers offered by isel - the operation of non-CAN-enabled modules or modules that are not directly compatible with this controller.

The necessary control inputs and outputs for this purpose are provided by the CPC12 module.

## Application figure

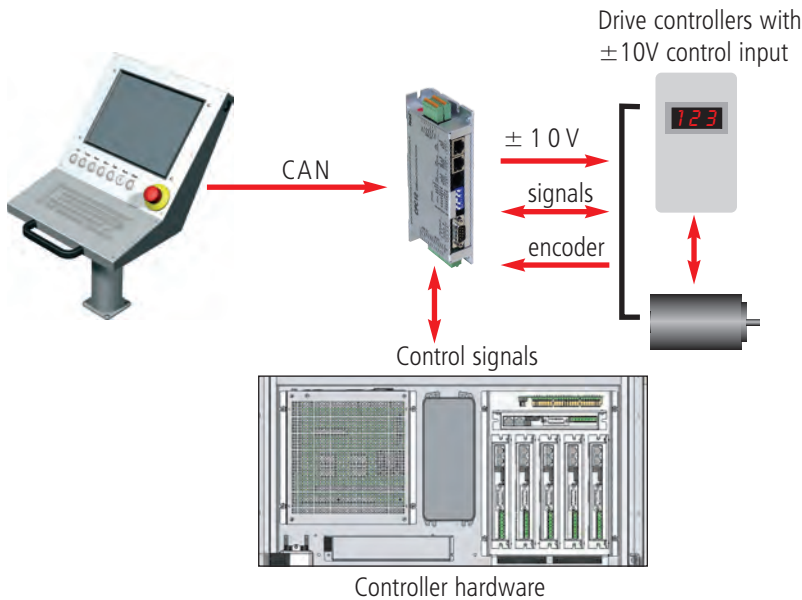

## Features

### CAN CPC 12 positioning module

- Controlling any number of drive controllers and frequency converters with  $\pm 10V$  input
- Digital position control with cycle time  $488 \mu s$
- Power supply  $+24V$  DC
- CANopen DS 301, DS 402, data transfer rate up to 1 Mbd
- RS232 for commissioning or PLC coupling
- Outputs for releasing external servo controllers and brake controllers
- Inputs for reference & limit switches
- Incremental encoder (RS422)
- Monitoring of limit switches for the positioning axes with emergency shutdown message
- Optionally as multi-axis solution in control cabinet
- Gantry mode or synchronous control of 2 modules, Master-Slave via CAN bus

Part no.: **320 210**

Subject to technical changes.

# Step controller IT116 Flash

## Single axis controller



Figure:  
IT 116 Flash front



Figure:  
IT 116 Flash back side

### General

The **IT 116 Flash step controller** is a freely programmable compact controller for a linear or circular axis with 2-phase stepper motor. The step controller comprises an intelligent step motor stage, a processor core with Flash memory for downloading/storing the PAL-PC user program and the clocking/direction signal generation for the final stage of the motor, the necessary power supply units, a safety circuit (Stop category 0 to EN 60204) and a casing with mains input filter and control elements.

The integrated operating system in the Flash memory of the processor core supports both

- DNC controller mode: PC/laptop connected permanently with the step controller via the serial interface

and the

- CNC controller mode: the step controller works independently, without PC coupling of the stored user program (standalone).

### Ordering information

IT 116 Flash step controller (115V AC, 60 Hz) Part no.: **381016 0115 \***  
 IT 116 Flash step controller (230V AC, 50 Hz) Part no.: **381016 \***

**\* including PAL-PC**

### Accessories

Motor lead  
 M23 12-pin socket - SubD 9-pin Pin  
 Part no.: **392755 0500** (5m)

Motor lead  
 SubD 9-pin socket - plug 1:1  
 Part no.: **392781 0500**

Other lengths on request.

### Features

- Final output stage  
 48 V DC / 4.2 A peak  
 for 2-phase stepper motors
- max. 25,600 microsteps/turn
- Mains voltage:  
 115V AC/230V AC, 50...60 Hz
- Automatic current sink at  
 50% phase current at  
 motor speed < 1 rpm
- Motor current/microstep resolution  
 variable with DIP switch
- Integrated 32-bit RISC processor  
 (Embedded controller) with Flash  
 memory for firmware and  
 PAL PC user program
- RS-232 interface (front) for  
 coupling with PC/notebook  
 (program download)
- Control signals:  
 Program start/stop, reset on  
 controller back side
- 4 optically isolated signal inputs  
 (Signal voltage: 24 V DC)
- 4 relay outputs (24 V DC, 300 mA)
- Motor brake controller (24 V DC)
- Remote plug on rear of controller  
 for external EMERGENCY SHUT-  
 DOWN (2-channel), ext. power on
- Euro cooling rib casing
- Programming with PAL-PC 2.1  
 for Win2000, XP, Vista, 7
- Dimensions  
 W 105 × H 111 × D 320 mm

### Scope of delivery

- Controller in cassette casing
- Mating plug (I/O, pulse, remote)
- Serial interface lead (SubD9 - RJ 45)
- 230V AC mains lead
- PAL-PC software CD
- Operating instructions
- Programming instructions

Subject to technical changes.

# Step controller

## Multiple axis controller

# iMC-P



Figure:  
Front and rear  
iMC-P step controller

### Features

- 8 signal inputs (24 V DC)
- 8 relay outputs (24 V DC, 300 mA) max. 2A total current
- 1 relay output (230 V AC/6 A)
- 1 analogue output (0 - 10 V)
- RS232 programming interface (rear)
- 32-bit RISC processor and memory for the user program
- Programming with PAL-PC (DNC and CNC modes), @-format (DNC and CNC modes), ProNC, Remote, Galaad, Labview (DNC mode), various high level languages
- Max. 4 final stages (48 V/4.2 A) for 2-phase stepper motors (power supply unit 500 W)
- From a step angle of 1.8° up to 25,600 microsteps/turn (1/128 microstep)
- Automatic current sink
- Motor current adjustable via DIP switch
- Additional control signals (start, stop, reset) adaptable
- Safety circuits (emergency shutdown, door circuit controller) via external plugs in higher level safety circuits integrable
- Broadband mains supply: 110 - 250V AC, 50..60 Hz
- Clocking/direction module to order
- Bench casing W 379 × H 137 × D260

### General

The step controllers **iMC-P** are freely programmable compact controllers with max. 4 final stages for 2-phase step motors. The controllers integrate all components (interfaces, motor controllers, voltage supplies, output stages, safety circuits, incl. door controller, control elements) needed to control a machine, in a compact bench housing. The iMC-P1 controller with core module and at least one integrated final stage enables the control of up to 3 additional final stages with clocking / direction module. The signals needed for this are provided by the appropriate external interfaces.

- **iMC-P1n**: with intelligent core module for control via RS232  
The controller also works either in DNC mode (permanently connected with the computer) or in CNC mode (after transfer of the user program as a standalone controller), e. g. via the accompanying PAL-PC software

n ... Number of axes

### Scope of delivery

- Controller
- Mating plug (I/O, pulse, remote)
- Serial interface lead (null modem)
- 230V AC mains lead
- PAL-PC software CD
- Operating and programming instructions

### Ordering information

2-axis controller iMC-P1-2  
3 axis controller iMC-P1-3  
4 axis controller iMC-P1-4  
USB - RS232 converter

Part no.: **381403 0002\***  
Part no.: **381403 0003\***  
Part no.: **381403 0004\***  
Part no.: **372000 0001**

\* including PAL-PC

### Accessories

Motor lead SubD9 plug - SubD9 socket  
Part no.: **392781 0500**

Motor lead SubD9 plug - M23 socket  
Part no.: **392755 0500** (5.00 m)

...other lengths available to order.

Subject to technical changes.



# Step controller

## Multiple axis controller

# iMC-S8



Figure:  
iMC-S8 step controller as  
bench version and with 19" housing

### Features

- 32-bit RISC processor with Flash memory for user program
- Final output stages
  - Step resolution and motor current adjustable via variable DIP switch
  - automatic current sink
- Acceleration, start-stop frequency and step output frequency variable
- both hardware limit switches configurable
- Door controller/hood controller
- Control elements in the front of the casing
- external EMERGENCY SHUTDOWN and POWER connection for integration in higher level safety circuits
- Connection for external control signals, such as START, STOP, RESET (only CNC mode)
- 230V connection for milling spindle (100-230V AC)
- 0 .. 10V analogue output for external frequency converter for speed-controlled main spindle
- Programming/Operation
  - PAL-PC in CNC mode (in the scope of delivery)
  - Remote (optional: ProNC) in DNC mode
  - isel @ - format in CNC/DNC modes

### General

The **iMC-S8** step controller is a freely programmable compact controller for linear or circular axes with 2-phase step motors.

The controller integrates all the necessary components (power supply, safety circuit, power electronics, core processor, interfaces, operating elements) that are needed to control individual spindles all the way to entire machines. It has an intelligent core module that is controlled and programmed via a RS232 interface. The core module also converts the commands programmed in the user program into clocking/direction signals for the connected final stages. Depending on the purpose, the **iMC-S8** controller can be used either in CNC or in DNC mode.

In CNC mode, the processor processes the CNC program which was previously produced with PAL-PC and stored in the controller's Flash memory.

In DNC mode, the **iMC-S8** controller is connected permanently with a control computer (PC, laptop) via a serial interface (RS232). Processing is carried out via the isel control software Remote.

### Technical specification

- Broadband mains supply  
100 - 250V AC, 50..60Hz
- Processor
  - Flash memory 128 kB,
  - Capacity to store 350 commands
  - max. step output frequency 40 kHz
- Final stages
  - Power supply 48V DC
  - Peak current: 2.8 - 7.8A
  - Step resolution: 400-51200 steps
- Inputs/outputs
  - 8 inputs (24V DC)
  - 8 outputs (24V DC/300mA, Itot 2A)
  - 1 relay output (230V AC, max. 6A)
  - 1 analogue output (0 - 10V)
- RS232 operating/programming interface
- Stop category 1, safety category 2
- Versions:
  - Bench casing  
W 475 × H 410 × D 187.5 mm
  - 19" housing  
W 482.5 × H 410 × D 175.5 mm

### Ordering information

2-axis iMC-S8 step controller, bench housing	Part no.: <b>383320 2002</b> *
2-axis iMC-S8 step controller, 19" housing	Part no.: <b>383320 1002</b> *
3-axis iMC-S8 step controller, bench housing	Part no.: <b>383320 2003</b> *
3-axis iMC-S8 step controller, 19" housing	Part no.: <b>383320 1003</b> *
4-axis iMC-S8 step controller, bench housing	Part no.: <b>383320 2004</b> *
4-axis iMC-S8 step controller, 19" housing	Part no.: <b>383320 1004</b> *

\* including PAL-PC

### Scope of delivery

Controller, mating plug (I/O, pulse, Remote), serial interface lead (null modem), 230V AC mains lead, PAL-PC software CD, operating instructions, programming instructions

### Accessories

Motor lead M23 plug - M23 socket  
Part no.: **392750 0300** (3m)  
Part no.: **392750 0500** (5m)

Motor lead M23 plug - SubD9 socket  
Part no.: **392752 0300** (3m)  
Part no.: **392752 0500** (5m)

Controller software - Remote  
Part no.: **Z12-334500**

Controller and programming software ProNC  
Part no.: **Z11-333500** Subject to technical changes.

# Single axis controller MC1-10/20/40

iMD single axis controller for isel linear units

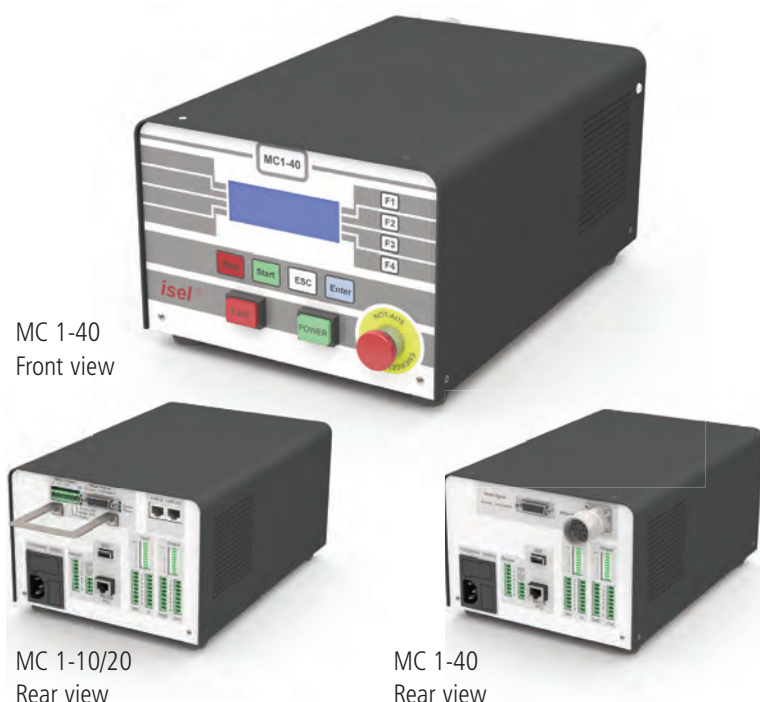

MC 1-40  
Front view

MC 1-10/20  
Rear view

MC 1-40  
Rear view

## General

MC 1 series servo-controllers are freely-programmable compact controllers for linear or rotating units with servomotors. The single axis controllers integrate all the components (interfaces, motion controller, power supply, drive controller, safety circuit, control elements) needed for axis control in compact bench housings. The supplied PAL-PC software can be used for programming

### There are three MC1 variants available:

- MC1-10: for controlling brush-type DC servomotors (48 V)
- MC1-20: for controlling brushless EC servomotors (48 V)
- MC1-40: for controlling brushless EC servomotors (310 V)

## Ordering information

MC 1-10 (including PAL-PC)	Part no.: <b>38d1518 0010</b>
MC 1-20 (including PAL-PC)	Part no.: <b>381518 0020</b>
MC 1-40 (including PAL-PC)	Part no.: <b>381518 0040</b>

Motor leads MC 1-10/20	Part no.: <b>392760 xxxx*</b>
Motor leads MC 1-40	Part no.: <b>392307 xxxx*</b>

Encoder lead	Part no.: <b>392740 xxxx*</b>
--------------	-------------------------------

\* Leads available in different lengths,  
e.g.: 0100 = 1 m / 0150 = 1.5 m / 0200 = 2 m ... / 1000 = 10 m

Subject to technical changes.

## Features

### MC1-10

- For controlling brush-type servomotors with an intermediate circuit voltage of 48 V DC
- Setup program "DcSetup"

### MC1-20

- For controlling brushless servomotors with an intermediate circuit voltage of 48 V DC
- Analysis of Hall signals
- Setup program "AcSetup"

### MC1-40

- For controlling brushless servomotors with an intermediate circuit voltage of 310V DC
- Analysis of Hall signals
- Setup program "AcSetup"

## Common features

- Max. output power 500 W (MC1-10, MC1-20)
- 32-bit high performance RISC processor with 256 kB Flash memory
- User program in CNC mode for up to 650 commands
- Processing of the program in CNC or DNC mode
- Programming with PAL-PC (CNC and CNC mode), @-format (CNC mode), ProNC, Remote (DNC mode)
- LC display with 4 lines, each with 20 characters (freely programmable)
- Additional control signals (Start, Stop) adaptable
- Connection for incremental encoder
- 6(8) signal inputs (24 V DC)
- 8 relay outputs (24 V DC/700 mA)
- Stop category 0 in accordance with EN60204
- Emergency shutdown circuit via plug in higher level safety circuit integrable
- Broadband mains supply:
  - 110...250 V AC, 50..60 Hz (MC1-10 / MC1-20)
  - 250 V AC, 50Hz (MC1-40)
- Bench casing  
W 204 × H 149 × D286

## Scope of delivery

- Controller
- Mating plug (I/O, pulse, remote)
- Serial interface lead (SubD9 - RJ 45)
- 230V AC mains lead
- PAL-PC software CD
- Operating instructions
- Programming instructions

# Multiple axis controller

iMD multiple axis controller for isel linear units

# iCU-DC / iCU-EC



iCU-DC  
Front view

iCU-DC  
Rear view

## General

The **CAN controllers** of the **iCU-DC** and **iCU-EC** series are compact, high-performance drive controllers for 2 - 6 DC servomotors and are offered at an optimal price / performance ratio.

The bench housing integrates all control components needed to solve a wide variety of automation tasks, ranging from the final stage via the I/O assembly to the safety controller.

The control computer has an integrated CANopen PCI card interface serving as CAN Master for the drive controller and I/O components. External upgrades are also possible, up to 128 CAN nodes. The connecting points at the rear of the control computer facilitate easy connection to (for example) a monitor. Peripherals such as a mouse and keyboard can be connected at the USB interfaces provided. LAN connection allows integration into an existing network and can be used for remote servicing.

The NC control core facilitates the interpolation of up to 6 axes (linear, circular, helical) as well as Online and Look Ahead machining. When using the ProNC software, individual axes can be controlled as handling axes (in addition to the interpolating axes).

All final stages have automatic jerk limitation and rest state monitoring (up to safety category 3).

## Ordering information

3 5 4 0 0 2 X 0 X 0

### Number of axes

- 2 = 2 axes
- 3 = 3 axes
- 4 = 4 axes
- 5 = 5 axes
- 6 = 6 axes

### Versions

- 1 = iCU DC\* (brush-type DC servomotors)
- 2 = iCU EC\* (brushless EC servomotors)

## Accessories

- Motor lead M23 pin - M23 socket  
Part no.: **392759 0300** (3m)
- Part no.: **392759 0500** (5m)

- Encoder lead SubD 15 plug - SubD15 socket  
Part no.: **392740 0300** (3m)
- Part no.: **392740 0500** (5m)

## Features

- Drive controller for up to 6 brush or brushless DC servo motors
- NC control via CANopen field bus
- iMD10/iMD20 final output stages
  - 4-quadrant drive controller
  - Analysis for incremental encoder
  - Rest state monitoring
  - Over- and undervoltage protection,
  - Overtemperature protection, short-circuit proof
- Door control / hood control
- External emergency cut-out for integration into higher level safety circuits
- Connection for external control signals (START, STOP, RESET) via signal inputs
- Control computer connections:
  - VGA, 4 x USB (2 x front, 2 x rear),
  - RJ45 Ethernet (100 Mbit/s)
- Connection for milling spindle (100 -230V AC)
- 0 ...10 V output for external frequency converter for speed-controlled main spindle
- Front-sided control elements
- Industrial control computer based on Windows® with
  - CANopen PCI board
  - driver software for CNC control
- Programming/Operation
  - Remote (optional: ProNC)

## Technical specification

- Broadband mains supply
  - 115 V AC / 230 V AC, 50...60 Hz
- Switching power supply 1000 W / 48 V
- iMD10/iMD20 final output stages
  - Power supply: 24...80 V DC
  - Peak / nominal current: 25 A / 12 A
- Input/output of CAN E/A module
  - 4 digital inputs, 8 digital outputs
  - 1 relay output (230V AC, max. 6 A)
  - 1 analog output (not required with frequency converter option)
- CAN safety circuit module
  - up to safety category 3
  - door circuit control
  - spindle control
- Bench casing
  - W 630 x H 230 x T 400 mm
- Options:
  - frequency converter for iSA500 - iSA2200
  - additional CAN I/O module (16 x inputs, 16 x outputs)

## Scope of delivery

- Controller
- Mating plug (I/O, pulse, remote)
- 230V AC mains lead
- Operating and programming instructions

Subject to technical changes.

# Power unit

## Multiple axis controller

# iPU-DC/iPU-EC



Figure:  
Power unit iPU as  
bench version and with 19" housing

### Features

- Drive controller for up to four brush or brushless DC servo motors
- NC control via CANopen field bus
- iMD10/iMD20 final output stages
  - 4-quadrant drive controller
  - Analysis for incremental encoder
  - Rest state monitoring
  - Over- and undervoltage protection, Overtemperature protection, short-circuit proof
- Door controller / hood controller
- Connection for external control signals, (EMERGENCY SHUTDOWN, START, STOP) for integration in higher level safety circuits
- Connection for milling spindle (100 -230V AC)
- 0 .. 10V output for external frequency converter for speed-controlled main spindle
- Front-sided control elements (optionally, installed in the rear)
- Two alternative casings
- Programming/Operation
  - Remote (optional: ProNC)

### General

The **iPU power units** are powerful drive controllers for up to four linear or circular axes with brush or brushless motors. The compact controller integrates all necessary controller components, which are needed to solve a wide range of automation tasks. These range from iMD10 or iMD20 final output stages through the I/O module to safety control and power electronics.

As its interface for NC control, the **iPU power unit** has a CANopen interface at the back of the housing, which works according to the DS301 bus protocol and DS402. By using the optional CAN PCI board iCC 10 or a iPC series control computer, the controller can control interpolation (linear, circular, helical) of all four axes as well as track processing.

The final output stages (iMD10 or iMD20) also have automatic jerk limitations and rest state monitoring. The control elements integrated in the front of the housing, such as EMERGENCY SHUTDOWN, START or STOP enable convenient operation.

### Technical specification

- Broadband mains supply
  - 115 V AC / 230 V AC, 50..60 Hz
- Switching power supply 1000 W / 48 V
- Final output stages iMD10 / iMD20
  - Power supply: 24 - 80 V DC
  - Peak / nominal current: 25 A / 12 A
- Inputs/outputs
  - 4 digital inputs (24 V DC / 8 mA)
  - 8 digital outputs (24 V DC / 350 mA)
  - 1 relay output (230 V AC, max. 6 A)
  - 1 analog output (0 - 10 V)
- Safety controller
  - up to safety category 3
  - door circuit and spindle control
- RJ 45 CANopen interface
- Versions:
  - Bench housing  
W 475 x H 410 x D 187.5 mm
  - 19" housing  
W 482.5 x H 410 x T 175.5 mm

### Ordering information

3 5 3 0 0 0 X 0 X X

#### Number of axes

- 2 = 2 axes
- 3 = 3 axes
- 4 = 4 axes

#### Versions

- 1 = 19" housing
- 2 = Bench housing

#### Drive controller

- 1 = iMD 10 (brush DC servomotors)
- 2 = iMD 20 (brushless EC servomotors)

\* in preparation, available to order

### Accessories

Motor lead M23 plug - M23 socket

Part no.: **392759 0300** (3m)

Encoder lead SubD15 plug - SubD15 socket

Part no.: **392759 0500** (5m)

CAN PCI board iCC 10 (single channel)

Part no.: **392740 0300** (3m)

CAN PCI board iCC 20 (2 channels)

Part no.: **392740 0500** (5m)

Controller software - Remote

Part no.: **320310**

ProNC control software

Part no.: **320311**

Part no.: **212-334500**

Part no.: **211-333500**

### Scope of delivery

- Controller
- Mating plug (I/O, pulse, remote)
- CAN bus lead (RJ45, patch lead)
- 230 V AC mains lead
- Operating instructions

Subject to technical changes.

# CAN-CNC controller

Example of a topology with the isel-CAN-CNC controller

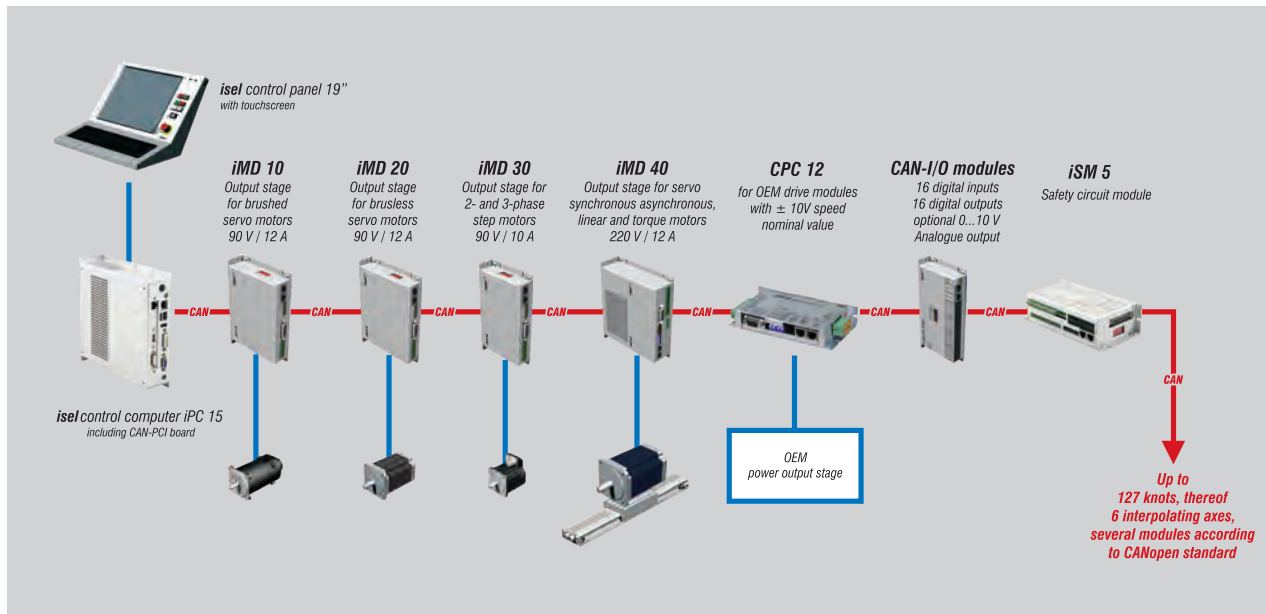

With consequent use of the CiA's (CAN in automation) **CANopen** standards, isel Germany delivers a high quality PC-based **CAN-CNC controller** for intelligent positioning/drive units and I/O modules.

The **CAN-CNC controller** supports interpolation operation (linear, circular and helical) of up to six positioning drives per machine and up to 127 handling axes and CAN modules.

The high time demands of a CNC controller are guaranteed by a WDM driver developed by isel. An additional real time operating system for Windows will be unnecessary. This guarantees compatibility with future Windows versions (Win7 in preparation)

The CAN controller is a pure software solution for PCs with Windows 2000/XP/VISTA. The CANopen PCI boards iCC 10/20 also act as an interface.

Owing to the features provided, the **CAN-CNC controller** is equally suited for all machining tasks, such as milling, engraving, drilling, turning, water jet and laser cutting, as well as for applications in automation systems.

For this purpose, **ProNC** provides a universal programming environment.

## Features

- Machine control to the **CANopen** standard as a pure software solution for PCs with Windows 2000/XP/VISTA
- CiA-Standard, DS 301, DSP 401, DSP 402
- Supports up to six positioning axes and 127 handling axes and CAN modules.
- Look ahead track processing with a freely definable number of movement elements, which the controller processes while looking ahead.
- Jerk limitation for elimination of mechanical vibrations
- Upstream speed control for highly dynamic and lag error-free machining
- Software tools for setting and optimising motor final stages/positioning modules
- Interfaces for PC:
  - CANopen PCI board iCC 10 (single channel)
  - CAN bus 1
  - CANopen PCI board iCC 20 (two channels)
  - CAN buses 1 and 2

Space for your notes